

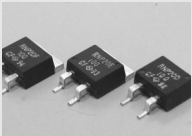

NIKKOHM PASSIVE COMPONENTS RESISTORS

Power Film & Wire wound
Current Shunt
Precision
Microwave
Thermal Sensor

Nikkohm Co., Ltd. Head Office
3-31-2640, Minamicho, Misawa, Aomori 033-0036 Japan
TEL: +81-176-53-2105 FAX: +81-176-53-2106
www.nikkohm.com / info@nikkohm.com

RNP Series (SMD)											TO-style Power Film Resistors				
Type	Style	Power (Watts)	Res. Range (ohms)	TCR (ppm)	Tol. (%)	W (mm)	H (mm)	L (mm)	P (mm)	page					
RNP-45	TO251	45	0.02-510K	*1	5%	8.2	12.0	0.8	5.08	21					
RNP-20D	TO263	35	0.02-510K	*1	1%, 5%	10.0	10.3	4.5	5.08	23					
RNP-20E	TO263	35	0.02-510K	*1	1%, 5%	10.0	10.3	4.5	5.08	23					
RNP-20F	TO263	35	0.02-510K	*1	1%, 5%	10.0	10.3	4.5	5.08	23					
RNP-50E	TO263	50	0.02-510K	*1	1%, 5%	10.0	10.3	4.5	5.08	26					
RMP-20S	TO220	35	0.02-510K	*1	1%, 5%	10.0	10.3	4.5	5.08	28					
RMP-50U	TO220	50	0.02-510K	*1	1%, 5%	10.0	10.3	4.5	5.08	31					

*1 Resistance 0.02-0.099: >250ppm/C, 0.1-510K: 100ppm/C, 10-51K: 50ppm/C

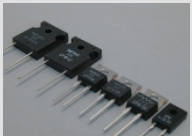
RNP Series											TO-style Power Film Resistors				
Type	Style	Power (Watts)	Res. Range (ohms)	TCR (ppm)	Tol. (%)	W (mm)	H (mm)	L (mm)	P (mm)	page					
RNP-10S	TO126	20	0.02-510K	*1	1%, 5%	8.5	12.0	3.1	5.08	33					
RNP-10	TO220	20	0.02-510K	*1	1%, 5%	10.1	15.0	4.5	5.08	35					
RNP-20S	TO220	35	0.02-510K	*1	1%, 5%	10.1	15.0	4.5	5.08	37					
RNP-50U	TO220	50	0.02-510K	*1	1%, 5%	10.1	15.0	4.5	5.08	39					
RNP-50S	TO247	100	0.02-510K	*1	1%, 5%	16.0	20.0	4.8	10.9	41					
RNP-100S	TO247	140	0.02-510K	*1	1%, 5%	16.0	20.0	4.8	10.9	43					
RNP-100U	TO247	100	0.02-510K	*1	1%, 5%	16.0	20.0	4.8	10.9	45					
RNP-140U	TO247	140	0.02-510K	*1	1%, 5%	16.0	20.0	4.8	10.9	47					

*1 Resistance 0.02-0.099: >250ppm/C, 0.1-510K: 100ppm/C, 10-51K: 50ppm/C

RPM Series											SOT-style Power Film Resistor				
Type	Style	Power (Watts)	Res. Range (ohms)	TCR (ppm)	Tol. (%)	W (mm)	H (mm)	L (mm)	P (mm)	page					
RPM150	SOT227	150	0.02-100K	*1	5%	38.0	11.8	25.0	13.0	49					
RPM200	SOT227	200	0.02-100K	*1	5%	38.0	11.8	25.0	13.0	49					
RPM250	SOT227	250	0.02-100K	*1	5%	38.0	11.8	25.0	13.0	49					
RPM300	SOT227	300	0.02-100K	*1	5%	38.0	11.8	25.0	13.0	49					
RPM550	SOT227	550	50-1K	*1	5%	38.0	11.8	25.0	13.0	49					
RPM600	SOT227	600	50-1K	*1	5%	38.0	11.8	25.0	13.0	49					
RPL320	----	300	0.1-51k	*1	5%	38.0	5.5	25.0	14.0	52					
RPL320L	----	300	0.1-51k	*1	5%	38.0	5.5	25.0	14.0	54					
RPK900	SOT227	900	50-1K	*1	5%	38.0	11.8	25.0	13.0	56					
RPK900L	SOT227	900	50-1K	*1	5%	38.0	11.8	25.0	13.0	59					

*1 Resistance 0.02-0.099: >250ppm/C, 0.1-100K: 100ppm/C

RPU Series											FLAT Power Film Resistors				
Type	Style	Power (Watts)	Res. Range (ohms)	TCR (ppm)	Tol. (%)	W (mm)	H (mm)	L (mm)	P (mm)	page					
RPU800	FLAT	800	0.5 – 1M	250	5%	69.0	60.0	28.0	---	62					
RPU1000	FLAT	1000	0.5 – 1M	250	5%	69.0	60.0	28.0	---	64					

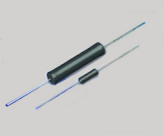
VT Series											Wire Wound Resistors
Type	Style	Power (Watts)	Res. Range (ohms)	TCR (ppm)	Tol. (%)	A (mm)	B (mm)	L (mm)	P (mm)	page	
VT-3	AXIAL	3	0.1 – 10K	200	1%	12.7	5.6	---	---	66	
VT-5	AXIAL	5	0.1 – 20K	200	1%	23.0	7.0	---	---	66	
VT-7	AXIAL	7	0.1 – 22K	200	1%	22.2	8.0	---	---	66	
VT-10	AXIAL	10	0.1 – 50K	200	1%	38.1	8.0	---	---	66	
VT-14	AXIAL	14	0.1 – 100K	200	1%	53.5	8.0	---	---	66	

*1

UT Series											High Voltage Resistors
Type	Style	Power (Watts)	Res. Range (ohms)	TCR (ppm)	Tol. (%)	A (mm)	B (mm)	C (mm)	P (mm)	page	
UT-20	cylinder	20	20 - 10T	100	1%	158	15	14	---	67	
UT-35	Cylinder	35	20 - 10T	100	1%	110	33	31	---	67	
UT-50	Cylinder	50	20 - 10T	100	1%	160	33	31	---	67	
UT-70	Cylinder	70	20 - 10T	100	1%	210	33	31	---	67	
UT-100	cylinder	100	20 - 10T	100	1%	310	33	31	---	67	
UT-150	cylinder	150	20 - 10T	100	1%	310	33	40	---	67	

*1

RPF, RPH Series											Screw Mount, Water Cooling, Power Film Resistor
Type	Style	Power (Watts)	Res. Range (ohms)	TCR (ppm)	Tol. (%)	W (mm)	H (mm)	L (mm)	P (mm)	page	
RPF100	Screw M	100	10-1K	250	10%	50.0	10.0	50.0	wire	69	
RPF250	Screw M	250	10-1K	250	10%	100.0	10.0	50.0	wire	69	
RPH500	Water C	500	10-1K	250	10%	70.0	15.0	30.0	wire	70	
RPH500S	Water C	500	0.22-1K	250	10%	102	81	70	---	73	
RPH1000S	Water C	1000	0.22-1K	250	10%	204	81	70	---	73	
RPH2000S	Water C	2000	0.22-1K	250	10%	204	---	70	---	73	

S Series											Wire Wound Resistors
Type	Style	Power (Watts)	Res. Range (ohms)	TCR (ppm)	Tol. (%)	L (mm)	W (mm)	H (mm)	P (mm)	page	
S-1	SMD	0.5	0.01 - 400	50	0.01-5	4.8	3.3	2.8		74	
S-2	SMD	1.0	0.005 – 3k	50	0.01-5	6.6	3.9	3.2		74	
S-3	SMD	2.0	0.01 – 15k	50	0.01-5	11.4	6.4	4.6		74	
S-4	SMD	3.0	0.01 – 25k	50	0.01-5	15.9	6.9	6.4		74	
S-5	SMD	5.0	0.01 – 50k	50	0.01-5	20.8	7.5	7.7		74	

*1

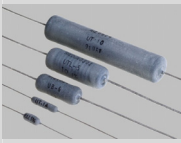
UT Series											Wire Wound Resistors
Type	Style	Power (Watts)	Res. Range (ohms)	TCR (ppm)	Tol. (%)	A (mm)	B (mm)	C (mm)	P (mm)	Page	
UT-1A	Axial	1.0	10k	20	0.1-5	10.3	2.4	0.5	---	76	
UT-2A	Axial	2.5	22k	20	0.1-5	12.7	4.7	0.8	---	76	
UT-2B	Axial	3.0	22k	20	0.1-5	14.2	4.7	0.8	---	76	
UT-3	Axial	4.0	45k	20	0.1-5	17.1	6.9	0.8	---	76	
UT-5	Axial	5.0	91k	20	0.1-5	22.2	7.9	1.0	---	76	
UT-6	Axial	5.0	95k	20	0.1-5	25.4	7.9	1.0	---	76	
UT-7A	Axial	7.0	150k	20	0.1-5	35.0	9.5	1.0	---	76	
UT-10	Axial	10.0	260k	20	0.1-5	45.2	9.5	1.0	---	76	
UT-15	Axial	15.0	320k	20	0.1-5	46.0	13.0	1.2	---	76	
*1											

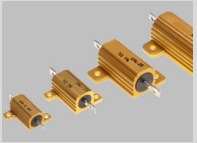
UAL Series											Metal Clad Wire Wound Resistors
Type	Style	Power (Watts)	Res. Range (ohms)	TCR (ppm)	Tol. (%)	W (mm)	H (mm)	L (mm)	P (mm)	page	
UAL-5	Metal C	20	0.022-25K	250	5% *1	27.1	16.0	15.6	---	78	
UAL-10	Metal C	20	0.1-10K	250	5% *1	27.1	16.0	15.6	---	78	
UAL-25	Metal C	30	0.048-50K	250	5% *1	70.6	16.0	15.6	---	78	
UAL-50	Metal C	30	0.2-20K	250	5% *1	70.6	16.0	15.6	---	78	

WD Series											Metal Clad Wire Wound Resistors
Type	Style	Power (Watts)	Res. Range (ohms)	TCR (ppm)	Tol. (%)	L (mm)	W (mm)	H (mm)	P (mm)	page	
WD75	Metal C	75	0.01 - 50K	60	0.25	48.9	48	26	---	80	
WD100	Metal C	100	0.01 - 100K	60	0.25	65.4	48	26	---	80	
WD150	Metal C	150	0.01 - 100K	60	0.25	97.0	48	26	---	80	
WD200	Metal C	200	0.01 - 50K	60	0.25	89.0	73	45	---	80	
WD250	Metal C	250	0.01 - 65K	60	0.25	114.0	73	45	---	80	
WD300	Metal C	300	0.01 - 80K	60	0.25	127.0	73	45	---	80	
*1 Tolerance: 0.1%, 0.5%, 1.0%, 5.0% are optionally available											

RH, IRS Series											Metal Clad Wire Wound Resistors
Type	Style	Power (Watts)	Res. Range (ohms)	TCR (ppm)	Tol. (%)	W (mm)	H (mm)	L (mm)	P (mm)	page	
RH25C	Metal C	20	0.022-25K	250	5% *1	27.1	16.0	15.6	---	82	
RH25CN	Metal C	20	0.1-10K	250	5% *1	27.1	16.0	15.6	---	82	
RH50C	Metal C	30	0.048-50K	250	5% *1	70.6	16.0	15.6	---	82	
RH50CN	Metal C	30	0.2-20K	250	5% *1	70.6	16.0	15.6	---	82	
*1 Tolerance: 0.1%, 0.5%, 1.0%, 5.0% are optionally available											

IRN, IRF Series											Flat Metal Clad Wire Wound Resistors
Type	Style	Power (Watts)	Res. Range (ohms)	TCR (ppm)	Tol. (%)	W (mm)	H (mm)	L (mm)	P (mm)	page	
IRN50	Metal C	50	1.0-0.42K	250	5.0 *2	60	10	70	wire	84	
IRN100	Metal C	100	1.0-1.1K	250	5.0 *2	60	10	120	wire	84	
IRN150	Metal C	150	1.0-1.75K	250	5.0 *2	60	10	170	wire	84	
IRF100	Metal C	100	1.0-1.1K	250	5.0 *2	80	10	90	wire	84	
IRF150	Metal C	150	1.0-1.75K	250	5.0 *2	80	10	120	wire	84	
IRF200	Metal C	200	1.0-2.2K	250	5.0 *2	80	10	150	wire	84	
IRF250	Metal C	250	1.0-2.97K	250	5.0 *2	80	10	180	wire	84	
IRF300	Metal C	300	1.0-3.50K	250	5.0 *2	80	10	210	wire	84	
IRF400	Metal C	400	1.0-4.45K	250	5.0 *2	80	10	270	wire	84	
IRF500	Metal C	500	1.0-5.78K	250	5.0 *2	80	10	330	wire	84	

*2 0.5, 1.0, 2.0 % are available

IRV, IRH Series											Metal Clad Wire Wound Resistors
Type	Style	Power (Watts)	Res. Range (ohms)	TCR (ppm)	Tol. (%)	W (mm)	H (mm)	L (mm)	P (mm)	page	
IRV60	Metal C	60	0.1 - 270	250	5% *2	22	41	100	W & T	87	
IRV80	Metal C	80	0.1 - 910	250	5% *2	22	41	150	W & T	87	
IRV100	Metal C	100	0.1 - 1.1K	250	5% *2	22	41	165	W & T	87	
IRV120	Metal C	120	0.1 - 1.3K	250	5% *2	22	41	182	W & T	87	
IRV150	Metal C	150	0.1 - 1.6K	250	5% *2	22	41	210	W & T	87	
IRV200	Metal C	200	0.1 - 2.2K	250	5% *2	30	60	165	W & T	87	
IRV300	Metal C	300	0.1 - 2.7K	250	5% *2	30	60	215	W & T	87	
IRV400	Metal C	400	0.1 - 4.3K	250	5% *2	30	60	265	W & T	87	
IRV500	Metal C	500	0.1 - 6.8K	250	5% *2	30	60	335	W & T	87	
IRH60	Metal C	60	0.1 - 270	250	5% *2	41	22	100	W & T	87	
IRH80	Metal C	80	0.1 - 910	250	5% *2	41	22	150	W & T	87	
IRH100	Metal C	100	0.1 - 1.1K	250	5% *2	41	22	165	W & T	87	
IRH120	Metal C	120	0.1 - 1.3K	250	5% *2	41	22	182	W & T	87	
IRH150	Metal C	150	0.1 - 1.6K	250	5% *2	41	22	210	W & T	87	
IRH200	Metal C	200	0.1 - 2.2K	250	5% *2	60	30	165	W & T	87	
IRH300	Metal C	300	0.1 - 2.7K	250	5% *2	60	30	215	W & T	87	
IRH400	Metal C	400	0.1 - 4.3K	250	5% *2	60	30	265	W & T	87	
IRH500	Metal C	500	0.1 - 6.8K	250	5% *2	60	30	335	W & T	87	

*1 no-inductive is available add "N". *2 Tolerance 0.5, 1.0, 2.0, are available. *3 "W & T": wires and metal tabs

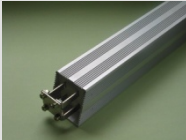
IRV, ULV Series											Metal Clad Wire Wound Resistors
Type	Style	Power (Watts)	Res. Range (ohms)	TCR (ppm)	Tol. (%)	W (mm)	H (mm)	L (mm)	P (mm)	page	
IRV600	Metal C	600	0.1- 94.0	250	5% *1	61	59	235	W & T	90	
IRV800	Metal C	800	0.1-112.0	250	5% *1	61	59	285	W & T	90	
IRV1000	Metal C	1000	0.1-140.0	250	5% *1	61	59	335	W & T	90	
IRV1200	Metal C	1200	0.1-160.0	250	5% *1	61	59	405	W & T	90	
ULV600	UL & MC	600	0.1- 94.0	250	5% *1	61	59	235	W & T	90	
ULV800	UL & MC	800	0.1-112.0	250	5% *1	61	59	285	W & T	90	
ULV1000	UL & MC	1000	0.1-140.0	250	5% *1	61	59	335	W & T	90	
ULV1200	UL 6 MC	1200	0.1-160.0	250	5% *1	61	59	405	W & T	90	

*1 0.5, 1.0, 2.0 % are available

NIKKOHM-INDEX

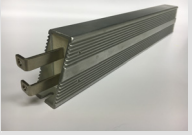
IRM, ULM Series											Metal Clad Wire Wound Resistors										
Type	Style	Power (Watts)	Res. Range (ohms)	TCR (ppm)	Tol. (%)	W (mm)	H (mm)	L (mm)	P (mm)	page											
IRM1600	Metal C	1600	0.1- 94.0	250	5% *1	50	100	330	---	93											
IRM2000	Metal C	2000	0.1-112.0	250	5% *1	50	100	400	---	93											
IRM2400	Metal C	2400	0.1-140.0	250	5% *1	50	100	480	---	93											
IRM2800	Metal C	2800	0.1-160.0	250	5% *1	50	100	550	---	93											
ULM1600	UL & MC	1600	0.1- 94.0	250	5% *1	50	100	330	---	93											
ULM2000	UL & MC	2000	0.1-112.0	250	5% *1	50	100	400	---	93											
ULM2400	UL & MC	2400	0.1-140.0	250	5% *1	50	100	480	---	93											
ULM2800	UL 6 MC	2800	0.1-160.0	250	5% *1	50	100	550	---	93											

*1 0.5, 1.0, 2.0 % are available

MBH/MBV Series											Metal Clad Wire Wound Resistors										
Type	Style	Power (Watts)	Res. Range (ohms)	TCR (ppm)	Tol. (%)	L (mm)	W (mm)	H (mm)	P (mm)	page											
MBH3000	Metal C	1100	0.4 - 150	200	5 - 10	330	270	73	---	95											
MBH3600	Metal C	1300	0.5 - 170	200	5 - 10	400	270	73	---	95											
MBH5000	Metal C	1500	0.6 - 180	200	5 - 10	450	270	73	---	95											
MBH7200	Metal C	2000	0.7 - 200	200	5 - 10	560	270	73	---	95											
MBH9800	Metal C	2500	0.8 - 220	200	5 - 10	660	270	73	---	95											
MBH10800	Metal C	2900	1.0 - 240	200	5 - 10	760	270	73	---	95											
MBV3000	Metal C	1100	0.4 - 150	200	5 - 10	330	270	73	---	95											
MBV3600	Metal C	1300	0.5 - 170	200	5 - 10	400	270	73	---	95											
MBV5000	Metal C	1500	0.6 - 180	200	5 - 10	450	270	73	---	95											
MBV7200	Metal C	2000	0.7 - 200	200	5 - 10	560	270	73	---	95											
MBV9800	Metal C	2500	0.8 - 220	200	5 - 10	660	270	73	---	95											
MBV10800	Metal C	2900	1.0 - 240	200	5 - 10	760	270	73	---	95											

*1 0.5, 1.0, 2.0 % are available

RCS CHIP Series											Metal Plate Shunt Resistors										
Type	Style	Power (Watts)	Res. Range (mohms)	TCR (ppm)	Tol. (%)	L (mm)	W (mm)	H (mm)	P (mm)	Page											
RCS2512	CHIP	3	0.5-5	100	1, 5	6.36	3.02	2.0	---	98											
RCS3920	CHIP	3	0.5-5	100	1, 5	10.0	5.2	2.0	---	98											
RCS5930	CHIP	5	0.5-5	100	1, 5	15.0	7.75	2.5	---	98											

*1 Dimension W happen to be changed by it's resistance

RCS Through Hole Chip Series											Metal Plate Shunt Resistors										
Type	Style	Power (Watts)	Res. Range (mohms)	TCR (ppm)	Tol. (%)	L (mm)	W (mm)	H (mm)	P (mm)	page											
RCS3820	CHIP	5	0.0003 - 0.002	100	5	9.16	5.30	----	---	100											

*1 Dimension W happen to be changed by it's resistance

RCS Bus Bar Series **Metal Plate Shunt Resistors**

Type	Style	Power (Watts)	Res. Range (mohms)	TCR (ppm)	Tol. (%)	L (mm)	W (mm)	H (mm)	DIA (mm)	page
RCS3	BUS BAR	3	0.0003 – 0.002	100	1 - 5	55	15	2	6.2	102
RCS551520	BUS BAR	3	0.0001 – 0.0005	100	1 - 5	55	15	2	6.2	104
RCS551521	BUS BAR	3	0.0001 – 0.0005	100	1 - 5	55	15	2	6.2	104
RCS842030	BUS BAR	15	0.0001 – 0.0005	100	1 - 5	84	20	3	8.5	106
RCS842031	BUS BAR	15	0.0001 – 0.0005	100	1 - 5	84	20	3	8.5	106
RCS851840	BUS BAR	36	0.0001-0.000125	200	1 - 5	85	18	4	7.0	108
RCS851841	BUS BAR	36	0.0001-0.000125	200	1 - 5	85	18	4	7.0	108



*1 Dimension W happen to be changed by it's resistance

FHR4 Series **Metal Plate Shunt Resistors**

Type	Style	Power (Watts)	Res. Range (mohms)	TCR (ppm)	Tol. (%)	W (mm)	H (mm)	L (mm)	P
FHR4-2321	TH	40	0.001 - 50	25	0.1 - 5	22.3	17.25	4.5	---
FHR4-3825	TH	50	0.001 - 100	25	0.1 - 5	38.0	24.0	6.0	---
RCS3825	TH	10	0.001 – 1.0	50	1	38.0	25.0	5.5	---
RAF30	BUS BAR	30	0.001 – 0.01	25	0.5	50.0	39.0	----	----

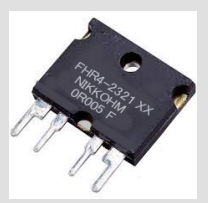

*1 Dimension W happen to be changed by it's resistance

RSN Series **Metal Plate Shunt Resistors**

Type	Style	Current (A)	Output Volt (mV)	TCR (ppm/K)	Tol. (%)	L (mm)	W (mm)	H (mm)	P (mm)	page
RSN-1	Screw	1	50, 100	20	0.1	152	31.75	35.05	91.26	119
RSN-2	Screw	2	50, 100	20	0.1	152	31.75	35.05	91.26	119
RSN-5	Screw	5	50, 100	20	0.1	152	31.75	35.05	91.26	119
RSN-10	Screw	10	50, 100	20	0.1	152	31.75	35.05	91.26	119
RSN-20	Screw	20	50, 100	20	0.1	152	31.75	35.05	91.26	119
RSN-50	Screw	50	50, 100	20	0.1	152	31.75	35.05	91.26	119
RSN-100	Screw	100	50, 100	20	0.1	152	31.75	35.05	91.26	119
RSN-150	Screw	150	50, 100	20	0.1	152	31.75	35.05	91.26	119
RSN-200	Screw	200	50, 100	20	0.1	152	31.75	35.05	91.26	119
RSN-250	Screw	250	50, 100	20	0.1	152	31.75	41.40	91.26	119
RSN-300	Screw	300	50, 100	20	0.1	152	31.75	41.40	91.26	119
RSN-400	Screw	400	50, 100	20	0.1	152	31.75	41.40	91.26	119
RSN-500	Screw	500	50, 100	20	0.1	152	31.75	41.40	91.26	119



NSLA, NSLB, NSLC Series											Metal Plate Shunt Resistors
Type	Style	Current (A)	Output Volt (mV)	TCR (ppm/K)	Tol. (%)	W (mm)	H (mm)	L (mm)	P (mm)	page	
NSLA10	Screw	10	50, 60	5	0.25	50.8	42.9	31.8	25.4	121	
NSLA15	Screw	15	50, 60	5	0.25	50.8	42.9	31.8	25.4	121	
NSLA20	Screw	20	50, 60	5	0.25	50.8	42.9	31.8	25.4	121	
NSLA30	Screw	30	50, 60	5	0.25	50.8	42.9	31.8	25.4	121	
NSLA50	Screw	50	50, 60	5	0.25	50.8	42.9	31.8	25.4	121	
NSLA75	Screw	75	50, 60	5	0.25	50.8	42.9	31.8	25.4	121	
NSLA80	Screw	80	50, 60	5	0.25	50.8	42.9	31.8	25.4	121	
NSLA85	Screw	85	50, 60	5	0.25	50.8	42.9	31.8	25.4	121	
NSLA100	Screw	100	50, 60	5	0.25	50.8	42.9	31.8	25.4	121	
NSLA150	Screw	150	50, 60	5	0.25	50.8	42.9	31.8	25.4	121	
NSLB170	Screw	170	50	5	0.25	82.5	44.5	44.5	38.1	124	
NSLB200	Screw	200	50	5	0.25	82.5	44.5	44.5	38.1	124	
NSLB250	Screw	250	50	5	0.25	82.5	44.5	44.5	38.1	124	
NSLB300	Screw	300	50	5	0.25	82.5	44.5	44.5	38.1	124	
NSLB400	Screw	400	50	5	0.25	82.5	44.5	44.5	38.1	124	
NSLB500	Screw	500	50	5	0.25	82.5	44.5	44.5	38.1	124	
NSLB600	Screw	600	50	5	0.25	82.5	44.5	44.5	38.1	124	
NSLC800	Screw	800	50	5	0.25	114	54.0	63.5	54.9	127	
NSLC1000	Screw	800	50	5	0.25	114	54.0	63.5	54.9	127	
NSLC1200	Screw	800	50	5	0.25	114	54.0	63.5	54.9	127	



NSA Series											Metal Plate Shunt Resistors
Type	Style	Current (A)	Output Volt (mV)	TCR (ppm/K)	Tol. (%)	W (mm)	H (mm)	L (mm)	P (mm)	page	
NSA50	1 screw	50	50, 60 *1	5	0.25	104.78	9.53	15.88	---	128	
NSA100	1 screw	100	50, 60 *1	5	0.25	104.78	9.53	15.88	---	128	
NSA150	1 screw	150	50, 60 *1	5	0.25	104.78	9.53	23.83	---	128	
NSA200	1 screw	200	50, 60 *1	5	0.25	104.78	12.70	20.75	---	128	
NSA250	1 screw	250	50, 60 *1	5	0.25	104.78	12.70	27.00	---	128	
NSA300	1 screw	300	50, 60 *1	5	0.25	104.78	12.70	31.75	---	128	
NSA400	1 screw	400	50, 60 *1	5	0.25	117.48	19.05	25.40	---	128	
NSA500	1 screw	500	50, 60 *1	5	0.25	117.48	19.05	31.75	---	128	
NSA600	1 screw	600	50, 60 *1	5	0.25	117.48	19.05	38.10	---	128	

*1 100mV is available under different dimensions.

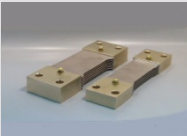

NSB Series											Metal Plate Shunt Resistors
Type	Style	Current (A)	Output Volt (mV)	TCR (ppm/K)	Tol. (%)	W (mm)	H (mm)	L (mm)	P (mm)	page	
NSB300	2 screws	300	50, 60 *1	5	0.25	149.23	12.70	44.45	---	131	
NSB400	2 screws	400	50, 60 *1	5	0.25	149.23	19.05	50.80	---	131	
NSB500	2 screws	500	50, 60 *1	5	0.25	149.23	19.05	50.80	---	131	
NSB600	2 screws	600	50, 60 *1	5	0.25	149.23	19.05	50.80	---	131	
NSB700	2 screws	700	50, 60 *1	5	0.25	149.23	19.05	57.15	---	131	
NSB800	2 screws	800	50, 60 *1	5	0.25	149.23	19.05	60.33	---	131	
NSB1000	2 screws	1000	50, 60 *1	5	0.25	149.23	25.40	63.50	---	131	
NSB1200	2 screws	1200	50, 60 *1	5	0.25	149.23	25.40	76.20	---	131	

*1 100mV is available under different dimensions.

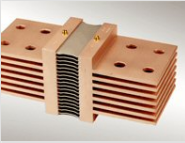

NSE Series											Metal Plate Shunt Resistors
Type	Style	Current (A)	Output Volt (mV)	TCR (ppm/K)	Tol. (%)	W (mm)	H (mm)	L (mm)	P (mm)	page	
NSE1500	4 screws	1500	50, 60	5	0.25	244.45	25.40	76.20	---	133	
NSE1500	4 screws	1500	100	5	0.25	285.75	25.40	76.20	---	133	
NSE2000	4 screws	2000	50, 60	5	0.25	244.45	25.40	76.20	---	133	
NSE2000	4 screws	2000	100	5	0.25	285.75	25.40	76.20	---	133	

NSF Series											Metal Plate Shunt Resistors
Type	Style	Current (A)	Output Volt (mV)	TCR (ppm)	Tol. (%)	W (mm)	H (mm)	L (mm)	P (mm)	page	
NSF2500	Bus Bar	2500	50 -100	5	0.25	101	38	320		135	
NSF3000	Bus Bar	3000	50 -100	5	0.25	101	50	320		135	
NSF4000	Bus Bar	4000	50 -100	5	0.25	101	76	320		135	
NSF5000	Bus Bar	5000	50 -100	5	0.25	101	76	320		135	
NSF6000	Bus Bar	6000	50 -100	5	0.25	101	101	320		135	
NSF7000	Bus Bar	7000	50 -100	5	0.25	101	101	320		135	
NSF8000	Bus Bar	8000	50 -100	5	0.25	101	101	320		135	
NSF9000	Bus Bar	9000	50 -100	5	0.25	101	101	320		135	
NSF10000	Bus Bar	10000	50 -100	5	0.25	101	101	320		135	

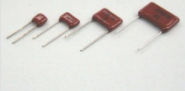
RP-44 Series											Thin Film Precision - Long Life Resistors
Type	Style	Power (W)	Res. Range (ohms)	TCR (ppm/K)	Tol. (%)	W (mm)	H (mm)	L (mm)	P (mm)	page	
RP-84	Radial	1/8	10-47K	(25) 50	(0.1) 1.0	5.0	5.0	2.5	2.5	137	
RP-44	Radial	1/4	10-180K	(25) 50	(0.1) 1.0	7.5	5.5	2.5	5.0	137	
RP-24	Radial	1/2	10-1M	(25) 50	(0.1) 1.0	*1	7.5	2.5	7.5	137	
RP-14	Radial	1.0	10-1M	(25) 50	(0.1) 1.0	14.0	8.5	2.5	*1	137	

* 25ppm/K TCR and 0.1% tolerance are option. 0.1-10M resistance are available. Tape, color, forming available.

RP-46 Series											Thin Film Precision Resistors
Type	Style	Power (W)	Res. Range (ohms)	TCR (ppm/K)	Tol. (%)	W (mm)	H (mm)	L (mm)	P (mm)	page	
RP-48	Radial	1/8	100-150K	2.5	0.02	5.6	8.2	2.54	2.54	140	
RP-47	Radial	1/4	100-150K	2.5	0.02	6.8	8.6	2.54	3.18	140	
RP-46	Radial	1/2	100-150K	2.5	0.02	8.0	9.0	2.54	5.08	140	
RP-45	Radial	1.0	100-150K	2.5	0.02	10.2	9.0	2.54	8.62	140	

* 25ppm/K TCR and 0.1% tolerance are optional. 0.1-10M resistance are available.

RP-42 Series **Thin Film Precision - Long Life Resistors**

Type	Style	Power (W)	Res. Range (ohms)	TCR (ppm/K)	Tol. (%)	W (mm)	H (mm)	L (mm)	P (mm)	page
RP-102	Radial	0.125	10-22K	50	1%	5.0	4.05	1.8	3.5	142
RP-82	Radial	0.25	10-250K	50	1%	6.3	4.05	2.2	5.0	142
RP-41	Radial	0.50	10-510K	50	1%	6.3	9.0	2.2	5.0	142
RP-42	Radial	0.50	10-1M	50	1%	9.0	6.3	2.2	7.5	142
RP-22	Radial	1.0	10-1M	50	1%	15.0	8.0	2.8	12.5	142
RP-23	Radial	1.0	10-1M	50	1%	17.0	6.3	2.8	15.0	142
RP-12	Radial	2.0	10-1M	50	1%	22.5	9.0	2.8	20.0	142
RP-203	Radial	3.0	10-1M	50	1%	22.5	15.0	3.55	20.0	142
RP-303	Radial	3.0	10-1M	50	1%	22.5	15.0	4.25	20.0	142

*5ppmTCR and 0.1% tolerance is available.

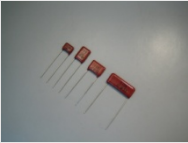

R Series **Thin Film Precision Chip Resistors**

Type	Style	Power (W)	Res. Range (ohms)	TCR (ppm/K)	Tol. (%)	L (mm)	W (mm)	H (mm)	P (mm)	page
R1206	Chip	0.25	25-50K	5 *1	0.05 *1	3.05	1.53	0.7	---	144
R1210	Chip	0.25	25-50K	5 *1	0.05 *1	3.05	2.54	0.7	---	144
R2010	Chip	0.5	25-100K	5 *1	0.05 *1	5.08	2.54	0.7	---	144
R2512	Chip	1.0	25-100K	5 *1	0.05 *1	6.35	3.05	0.7	---	144
R3010	Chip	2.0	25-100K	5 *1	0.05 *1	7.62	5.08	0.7	---	144

*1 25ppm/K TCR and 0.1% tolerance are optional. 0.1-10M resistance is optional.

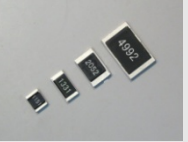

NQA Series **Thin Film Precision Chip Resistors**

Type	Style	Power (W)	Res. Range (ohms)	TCR (ppm/K)	Tol. (%)	L (mm)	W (mm)	H (mm)	P (mm)	page
NQA1/8	Chip	0.125	100-33K	2	0.05 *1	3.2	2.5	1.0	---	147
NQA1/4	Chip	0.250	100-62K	2	0.05 *1	4.5	3.2	1.0	---	147

* 5ppm-0.1%, 5ppm-0.05% are available.



RPC Series **Thin Film Power Chip Resistors**

Type	Style	Power (W)	Res. Range (ohms)	TCR (ppm/K)	Tol. (%)	L (mm)	W (mm)	H (mm)	P (mm)	page
RPC14	Chip	0.25	10-200K	50	1.0	3.2	2.6	0.7	---	150
RPC12	Chip	0.5	10-200K	50	1.0	5.0	2.5	0.7	---	150
RPC11	Chip	1.0	10-1M	50	1.0	5.7	3.8	0.7	---	150
RPC21	Chip	2.0	10-1M	50	1.0	8.5	5.5	0.7	---	150

*

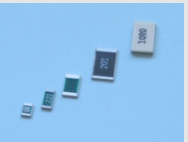



CAR Series **Thin Film Chip Resistors**

Type	Style	Power (W)	Res. Range (ohms)	TCR (ppm/K)	Tol. (%)	L (mm)	W (mm)	H (mm)	P (mm)	page
CAR0402	Chip	1/16	1 - 255K	5 - 50	0.01 - 1	1.00	0.5	0.3	---	152
CAR0603	Chip	1/16	1 - 1M	5 - 50	0.01 - 1	1.55	0.8	0.45	---	152
CAR0805	Chip	1/10	1 - 2.49M	5 - 50	0.01 - 1	2.00	1.25	0.55	---	152
CAR1206	Chip	1/8	1-2.49M	5 - 50	0.01 - 1	3.05	1.55	0.55	---	152
CAR2010	Chip	1/4	1 - 3M	5 - 50	0.01 - 1	4.90	2.40	0.55	---	152
CAR2512	Chip	1/2	1 - 3M	5 - 50	0.01 - 1	6.3	3.1	0.55	---	152

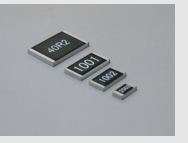
*



CRW Series											Thick Film Chip Resistors
Type	Style	Power (W)	Res. Range (ohms)	TCR (ppm/K)	Tol. (%)	L (mm)	W (mm)	H (mm)	P (mm)	page	
CRW1210	Chip	0.35	0.1-100M	50 - 250	1 - 10	3.2	2.5	0.5	---	155	
CRW1216	Chip	0.5	0.1-100M	50 - 250	1 - 10	3.2	4.1	0.5	---	155	
CRW2010	Chip	0.75	0.1-100M	50 - 250	1 - 10	5.1	2.5	0.6	---	155	
CRW2040	Chip	2.0	0.1-100M	50 - 250	1 - 10	5.1	10.2	0.6	---	155	
CRW2512	Chip	1.0	0.1-100M	50 - 250	1 - 10	6.3	3.5	0.6	---	155	
CRW4020	Chip	2.0	0.1-100M	50 - 250	1 - 10	10.2	5.1	0.6	---	155	
*											

CLSA Series											Low Resistance Thick Film Chip Resistors
Type	Style	Power (W)	Res. Range (ohms)	TCR (ppm/K)	Tol. (%)	L (mm)	W (mm)	H (mm)	P (mm)	page	
CLSA0402	Chip	0.06	0.05 - 1.0	200 - 600	1 - 5	1.0	0.5	---	---	157	
CLSA0603	Chip	0.1	0.02 - 1.0	200 - 600	1 - 5	1.6	0.8	---	---	157	
CLSA0805	Chip	0.125	0.02 - 1.0	200 - 600	1 - 5	2.0	1.25	---	---	157	
CLSA1206	Chip	0.25	0.01 - 1.0	200 - 600	1 - 5	3.1	1.55	---	---	157	
CLSA2010	Chip	0.75	0.01 - 1.0	200 - 600	1 - 5	5.0	2.50	---	---	157	
CLSA2512	Chip	1.0	0.01 - 1.0	200 - 600	1 - 5	6.3	3.10	---	---	157	
*											

CHR Series											High Resistance Thick Film Chip Resistors
Type	Style	Power (W)	Res. Range (ohms)	TCR (ppm/K)	Tol. (%)	L (mm)	W (mm)	H (mm)	P (mm)	page	
CHR0402	Chip	0.05	1 - 10M	50 - 250	1 - 10	0.95	0.48	0.28	---	159	
CHR0603	Chip	0.10	1 - 10M	50 - 250	1 - 10	1.50	0.80	0.40	---	159	
CHR0805	Chip	0.125	1 - 10M	50 - 250	1 - 10	2.0	1.25	0.40	---	159	
CHR1206	Chip	0.25	1 - 10M	50 - 250	1 - 10	3.2	1.50	0.40	---	159	
CHR1210	Chip	0.50	1 - 10M	50 - 250	1 - 10	5.1	2.50	0.60	---	159	
CHR2512	Chip	1.00	1 - 10M	50 - 250	1 - 10	6.3	3.50	0.60	---	159	
CHR4020	Chip	2.00	1 - 10M	50 - 250	1 - 10	10.2	5.10	0.60	---	159	
*											

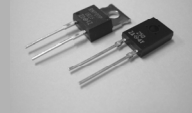
TO126, TO220 Series											Thin Film Precision Power Resistors
Type	Style	Power (W)	Res. Range (ohms)	TCR (ppm/K)	Tol. (%)	W (mm)	H (mm)	L (mm)	P (mm)	page	
RNP-10P	TO220	10	1-51K	5	0.1	8.5	12.0	3.1	5.08	161	
RNP-20P	TO220	10	1-51K	5	0.1	10.1	15.0	4.5	5.08	163	

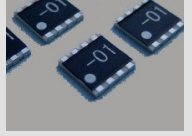
MCM Series											Thin Film Precision Networks
Type	Style	Power (W)	Res. Range (ohms)	TCR (ppm/K)	Tol. (%)	W (mm)	L (mm)	H (mm)	P (mm)	page	
MCM4	SOIC	0.05	100-22K	5-2	0.05-0.02	5.00	3.00	0.8	1.27	165	
MCM8	SOIC	0.05	100-22K	5-2	0.05-0.02	5.00	5.00	0.8	1.27	165	
MCM16	SOIC	0.05	100-22K	5-2	0.05-0.02	5.00	10.00	0.8	1.27	165	
* TCR and tolerance show matching and trucking.											

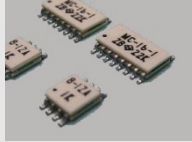
MC Series											Thin Film Precision Networks
Type	Style	Power (W)	Res. Range (ohms)	TCR (ppm/K)	Tol. (%)	W (mm)	L (mm)	H (mm)	P (mm)	page	
MC8	SOP	0.05	100-22K	5	0.05, 0.1	5.3	3.5	2.3	1.27	167	
MC16	SOP	0.05	100-22K	5	0.05, 0.1	5.3	5.5	2.3	1.27	167	
MC20	SOP	0.05	100-22K	5	0.05, 0.1	5.3	10.5	2.3	1.27	167	
MCL6	SOP	0.10	10K-20K *1	5	1/2 LSB	5.3	3.5	2.3	1.27	169	
MCL8	SOP	0.10	10K-20K *1	5	1/2 LSB	5.3	5.5	2.3	1.27	169	
MCL10	SOP	0.10	10K-20K *1	5	1/2 LSB	5.3	10.5	2.3	1.27	169	

*1 R-2R ladder is available in 1K-2K.

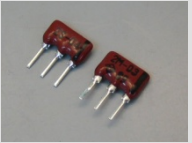
2M, 2S, 2T Series											Thin Film Precision Networks
Type	Style	Power (W)	Res. Range (ohms)	TCR (ppm/K)	Tol. (%)	W (mm)	H (mm)	L (mm)	P (mm)	page	
2M00	SIP	0.125	500-50K *1	5	0.1	8.0	7.0	2.54	2.54	171	
2S00	SIP	0.125	500-50K *1	5	0.1	8.0	5.0	2.54	2.54	171	
2T00	SIP	0.125	500-50K *1	5	0.1	8.0	5.0	2.54	2.54	171	

*1 Resistance ratio is limited under 5 times.

MP Series											Thin Film Precision Networks
Type	Style	Power (W)	Res. Range (ohms)	TCR (ppm/K)	Tol. (%)	W (mm)	H (mm)	L (mm)	P (mm)	page	
MP-3S	SIP	0.125	47-22K	5 / 1	0.1 / 0.05	10.2	7.0	3.0	2.54	173	
MP-4S	SIP	0.125	47-22K	5 / 1	0.1 / 0.05	12.7	7.0	3.0	2.54	173	
MP-5S	SIP	0.125	47-22K	5 / 1	0.1 / 0.05	15.2	7.0	3.0	2.54	173	
MP-6S	SIP	0.125	47-22K	5 / 1	0.1 / 0.05	17.8	7.0	3.0	2.54	173	
MP-4P	SIP	0.125	47-22K	5 / 1	0.1 / 0.05	12.7	7.0	3.0	2.54	173	
MP-5P	SIP	0.125	47-22K	5 / 1	0.1 / 0.05	15.2	7.0	3.0	2.54	173	
MP-6P	SIP	0.125	47-22K	5 / 1	0.1 / 0.05	17.8	7.0	3.0	2.54	173	
MP-7P	SIP	0.125	47-22K	5 / 1	0.1 / 0.05	20.3	7.0	3.0	2.54	173	
MP-8P	SIP	0.125	47-22K	5 / 1	0.1 / 0.05	22.9	7.0	3.0	2.54	173	
MP-2I	SIP	0.125	47-22K	5 / 1	0.1 / 0.05	10.2	7.0	3.0	2.54	173	
MP-3I	SIP	0.125	47-22K	5 / 1	0.1 / 0.05	15.2	7.0	3.0	2.54	173	
MP-4I	SIP	0.125	47-22K	5 / 1	0.1 / 0.05	20.3	7.0	3.0	2.54	173	

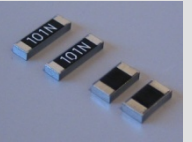
RFH Series											Microwave Consumption Resistors
Type	Style	Power (W)	Res. Range (ohms)	TCR (ppm/K)	Tol. (%)	L (mm)	W (mm)	H (mm)	P (mm)	page	
RFH52	Chip	10	* 1	50	1.0	5.0	2.5	1.2	---	175	
RFH72	Chip	10	* 1	50	1.0	7.0	2.0	1.2	---	175	
RFK52	Chip	20	* 1	50	1.0	5.0	2.5	1.2	---	175	
RFK72	Chip	20	* 1	50	1.0	7.0	2.0	1.2	---	175	

* 1: 50, 100, 150, 200, 250, 300, 400, 600, 800 ohms

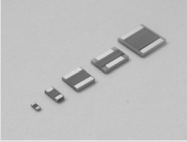
RFR Series											Microwave Chip Resistors
Type	Style	Power (W)	Res. Range (ohms)	TCR (ppm/K)	Tol. (%)	L (mm)	W (mm)	H (mm)	P (mm)	page	
RFR010 010	Chip	10	*1	50	1.0	5.08	2.54	1.05	---	175	
RFR010 020	Chip	10	*1	50	1.0	5.08	2.54	1.05	---	175	
RFR050 010	Chip	50	*1	50	1.0	5.08	5.08	10.5	---	175	
RFR050 020	Chip	50	*1	50	1.0	5.08	5.08	10.5	---	175	
RFR100 010	Chip	100	*1	50	1.0	5.84	8.89	1.05	---	175	
RFR100 020	Chip	100	*1	50	1.0	5.84	8.89	1.05	---	175	
RFR250 010	Chip	250	*1	50	1.0	9.52	9.52	1.05	---	175	
RFR250 020	Chip	250	*1	50	1.0	9.52	9.52	1.05	---	175	

*1: 50, 100, 150, 200, 250, 300, 400, 500, 800 ohms

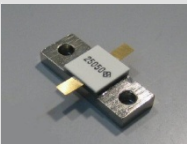
RFR Series											Microwave Flanged Resistors
Type	Style	Power (W)	Res. Range (ohms)	TCR (ppm/K)	Tol. (%)	L (mm)	W (mm)	H (mm)	P (mm)	page	
RFR010 120	Flange	10	*1	50	1.0	7.10	5.10	3.10	---	179	
RFR050 120	Flange	50	*1	50	1.0	13.80	6.35	3.10	---	179	
RFR050 110	Flange	50	*1	50	1.0	20.30	5.70	3.10	---	179	
RFR100 110	Flange	100	*1	50	1.0	20.30	6.35	3.10	---	179	
RFR150 110	Flange	150	*1	50	1.0	22.10	9.52	4.00	---	179	
RFR200 110	Flange	200	*1	50	1.0	24.77	9.52	5.08	---	179	
RFR250 110	Flange	250	*1	50	1.0	22.10	9.52	4.00	---	179	
RFR400 110	Flange	400	*1	50	1.0	31.80	12.70	5.33	---	179	
RFR600 110	Flange	600	*1	50	1.0	48.26	26.42	5.59	---	179	

*1: 50, 100, 150, 200, 250, 300, 400, 500, 800 ohms

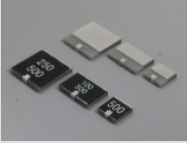
RFT Series											Microwave Chip Terminations
Type	Style	Power (W)	Impedance (ohms)	TCR (ppm/K)	Tol. (%)	L (mm)	W (mm)	H (mm)	P (mm)	page	
RFT010 010	Chip	10	50	50	1.0	5.08	2.54	1.05	---	181	
RFT010 020	Chip	10	50	50	1.0	5.08	2.54	1.05	---	181	
RFT050 010	Chip	50	50	50	1.0	5.08	5.08	1.05	---	181	
RFT050 020	Chip	50	50	50	1.0	5.08	5.08	1.05	---	181	
RFT100 010	Chip	100	50	50	1.0	5.84	8.89	1.05	---	181	
RFT100 020	Chip	100	50	50	1.0	5.84	8.89	1.05	---	181	
RFT150 010	Chip	150	50	50	1.0	6.35	9.52	1.05	---	181	
RFT150 020	Chip	150	50	50	1.0	6.35	9.52	1.05	---	181	
RFT250 010	Chip	250	50	50	1.0	9.52	9.52	1.05	---	181	
RFT250 020	Chip	250	50	50	1.0	9.52	9.52	1.05	---	181	

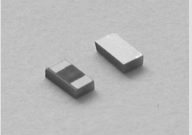
RFTS Series											Microwave Chip Terminations	
Type	Style	Power (W)	Impedance (ohms)	TCR (ppm/K)	Tol. (%)	L (mm)	W (mm)	H (mm)	P (mm)	page		
RFTS05	ZF0	Chip	5	50	50	1.0	2.54	1.27	0.63	---		184
RFTS05	ZE0	Chip	5	50	50	1.0	2.54	1.27	0.63	---		184
RFTS05	ZZ0	Chip	5	50	50	1.0	2.54	1.27	0.63	---		184
RFTS05	ZY0	Chip	5	50	50	1.0	2.54	1.27	0.63	---		184
RFTS10	ZF0	Chip	10	50	50	1.0	5.08	2.54	1.00	---		184
RFTS10	ZE0	Chip	10	50	50	1.0	5.08	2.54	1.00	---		184
RFTS10	ZZ0	Chip	10	50	50	1.0	5.08	2.54	1.00	---		184
RFTS10	ZY0	Chip	10	50	50	1.0	5.08	2.54	1.00	---		184
RFTS50	ZF0	Chip	50	50	50	1.0	5.08	5.08	1.00	---		184
RFTS50	ZE0	Chip	50	50	50	1.0	5.08	5.08	1.00	---		184
RFTS50	ZZ0	Chip	50	50	50	1.0	5.08	5.08	1.00	---		184
RFTS50	ZY0	Chip	50	50	50	1.0	5.08	5.08	1.00	---		184

*1: F, E, Z, Y show terminal configuration4

RFT Series											Microwave Flange Terminations	
Type	Style	Power (W)	Impedance (ohms)	TCR (ppm/K)	Tol. (%)	L (mm)	W (mm)	H (mm)	P (mm)	page		
RFT010	120	Flange	10	50	50	1.0	7.10	5.10	3.10	---		188
RFT050	120	Flange	50	50	50	1.0	13.08	6.35	3.10	---		188
RFT050	130	Flange	50	50	50	1.0	13.08	6.35	3.10	---		188
RFT050	140	Flange	50	50	50	1.0	13.08	6.35	3.10	---		188
RFT080	120	Flange	80	50	50	1.0	13.08	6.35	3.10	---		188
RFT080	130	Flange	80	50	50	1.0	13.08	6.35	3.10	---		188
RFT080	140	Flange	80	50	50	1.0	13.08	6.35	3.10	---		188
RFT050	110	Flange	50	50	50	1.0	20.30	5.70	3.10	---		188
RFT100	110	Flange	100	50	50	1.0	20.30	6.35	3.10	---		188
RFT150	110	Flange	150	50	50	1.0	22.10	9.52	3.10	---		188
RFT250	110	Flange	250	50	50	1.0	22.10	9.52	4.00	---		188
RFT400	110	Flange	400	50	50	1.0	31.80	12.70	5.33	---		188
RFT600	110	Flange	600	50	50	1.0	48.26	26.42	5.59	---	188	

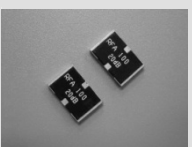
RFA Series											Microwave Chip Attenuators	
Type	Style	Power (W)	Attenuation (dB)	Imp (ohms)	Tol. (%)	L (mm)	W (mm)	H (mm)	P (mm)	page		
RFA001	010	Chip	1	*1	50	2.0	4.00	4.00	0.65	---		190
RFA1206		Chip	0.25	6, 8, 10, 20	50	2.0	3.20	1.60	0.63	---		192
RFA010	020	Chip	10	10, 20, 30	50	2.0	5.08	2.54	1.1	---		194
RFA020	010	Chip	20	10, 20, 30	50	2.0	5.08	5.08	1.1	---		194
RFA020	020	Chip	20	10, 20, 30	50	2.0	5.08	5.08	1.1	---		194
RFA040	010	Chip	40	10, 20, 30	50	2.0	---	---	---	---		194
RFA100	010	Chip	100	10, 20, 30	50	2.0	5.08	8.89	1.1	---		194
RFA150	010	Chip	150	10, 20, 30	50	2.0	6.35	9.52	1.1	---		194

*1: 0, 1, 2, 3, 4, 5, 6, 7, 8, 9, 10, 20 dB

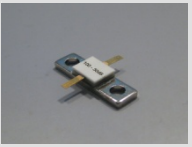
RFA Series											Microwave Flange Attenuators
Type	Style	Power (W)	Attenuation (dB)	Imp (ohms)	Tol. (%)	L (mm)	W (mm)	H (mm)	P (mm)	page	
RFA010 110	Chip	10	*1	50	2.0	----	----	----	----		
RFA020 110	Chip	20	10, 20, 30	50	2.0	----	----	----	----		
RFA040 110	Chip	40	10, 20, 30	50	2.0	----	----	----	----		
RFA100 110	Chip	100	10, 20, 30	50	2.0	20.30	5.90	2.70	---	197	
RFA150 110	Chip	150	10, 20, 30	50	2.0	22.10	9.52	2.70	---	199	
*1: 1, 3, 6, 10, 20, 30 dB											

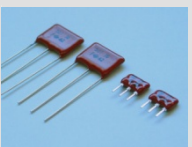
RFA50T Series											Microwave Radial Leaded Attenuators
Type	Style	Power (W)	Attenuation (dB)	Imp (ohms)	Tol. (%)	W (mm)	H (mm)	L (mm)	P (mm)	page	
RFA50TF	Radial	---	*1	50	1.0	8.00	7.00	3.0	2.54	201	
RFA75TF	Radial	---	*1	75	1.0	8.00	7.00	3.0	2.54	201	
RFA300TF	Radial	---	*1	300	1.0	8.00	7.00	3.0	2.54	201	
RFA600TF	Radial	---	*1	600	1.0	8.00	7.00	3.0	2.54	201	
RFA50T	Radial	---	*1	50	1.0	13.00	11.50	2.5	5.0	201	
RFA75T	Radial	---	*1	75	1.0	13.00	11.50	2.5	5.0	201	
RFA300T	Radial	---	*1	300	1.0	13.00	11.50	2.5	5.0	201	
RFA600T	Radial	---	*1	600	1.0	13.00	11.50	2.5	5.0	201	
*1: 2,3,4,5,6,7,8,9,10,16, 20,30 dB											

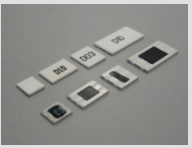
RFA Series											Microwave Coaxial Attenuators
Type	Style	Power (W)	Attenuation (dB)	Imp (ohms)	Tol. (%)	L (mm)	W (mm)	H (mm)	P (mm)	page	
RFA54DD	Coax	0.25	*1	50 *2	2.0	5.00	3.80	0.70	---	204	
RFA55DD	Coax	0.25	*1	50 *2	2.0	5.00	4.50	0.70	---	204	
RFA85DD	Coax	0.50	*1	50 *2	2.0	8.00	5.25	0.70	---	204	
RFA67DD	Coax	1.00	*1	50 *2	2.0	6.00	7.00	0.70	---	204	
RFA37DD	Coax	1.00	*1	50 *2	2.0	13.00	7.00	0.70	---	204	
*1: 2,3,4,5,6,7,8,9,10,16, 20,30 dB, *2 75 ohm impedance is available by additional characters "DC"											

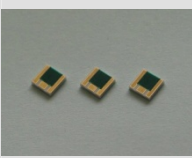
RFD Series											Microwave Coaxial Terminations
Type	Style	Power (W)	Impedance (ohms)	TCR (ppm/K)	Tol. (%)	L (mm)	W (mm)	H (mm)	P (mm)	page	
RFD3350	Coax	0.25	50	50	2.0	3.80	2.70	0.70	---	208	
RFD4450	Coax	0.25	50	50	2.0	3.80	2.70	0.70	---	208	
RFD5450	Coax	0.50	50	50	2.0	5.40	4.20	0.70	---	208	
RFD8750	Coax	1.00	50	50	2.0	8.00	7.00	0.70	---	208	

JSTC Series											Multi-junction Thermal Converters										
Type	Style	Power (W)	Input Resistance (ohms)	Output Resistance (ohms)	Sensitivity (V/W)	L (mm)	W (mm)	H (mm)	P (mm)	page											
JSTC04	Device	0.10	*1	< 400	0.6	15.00	9.00	3.50	---	209											
JSTC05	Device	0.10	*1	< 400	0.6	15.00	9.00	3.50	---	211											
JSTC06	Device	0.10	*1	< 400	0.6	15.00	9.00	3.50	---	213											
TVC04A	Unit	0.10	*1	< 400	0.6	73.5	28.0	37.6	---	215											
TVC05B	Unit	0.10	*1	< 400	0.6	73.5	28.0	28.0	---	215											
TVC06A	Unit	0.10	*1	< 400	0.6	73.5	28.0	37.6	---	215											
TVC06B	Unit	0.10	*1	< 400	0.6	73.5	28.0	28.0	---	215											
TVCC04AR	Case	---	---	---	---	35.0	28.0	28.0	---	217											
TVCC04AP	Case	---	---	---	---	35.0	28.0	28.0	---	217											
TVCC05BR	Case	---	---	---	---	35.0	28.0	28.0	---	217											
TVCC05BP	Case	---	---	---	---	35.0	28.0	28.0	---	217											
TVCC06AR	Case	---	---	---	---	35.0	28.0	28.0	---	217											
TVCC06AP	Case	---	---	---	---	35.0	28.0	28.0	---	217											
TVCC06BR	Case	---	---	---	---	35.0	28.0	28.0	---	217											
TVCC06BP	Case	---	---	---	---	35.0	28.0	28.0	---	217											

* 1: 100, 200, 500, 700, 1K, 2Kohm

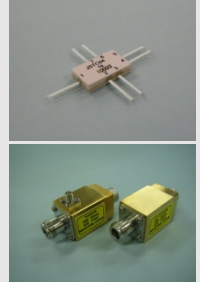

LP Series											Multi-junction Thermal Converters										
Type	Style	Power (W)	Input Resistance (ohms)	Output Resistance (ohms)	Sensitivity (V/W)	L (mm)	W (mm)	H (mm)	P (mm)	page											
LP73F	---	0.01	50	2K +/- 1K	13 +/- 2	15.00	15.00	3.90	---	219											
LP34B	---	0.01	50, 75	< 3K	> 2	25.00	12.50	4.50	---	221											
LP34TW	---	0.01	50, 75	< 12K	> 1.4	32.00	22.00	5.50	---	221											

*

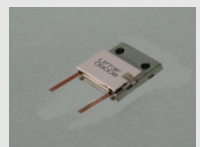

LP Series											Thermopile Detector										
Type	Style	Power (W)	Response (ms)	Output Resistance (ohms)	Sensitivity (V/W)	D (mm)	H (mm)	L (mm)	P (mm)	page											
LP111S	TO5	0.01	45	2K	10.0	9.05	3.5	---	---	223											
LP123S	---	0.01	45	1K	5.0	9.05	3.5	---	---	223											
LP231	---	0.01	250	4K	4.5	15.24	4.4	---	---	---											

*



Blank page

Blank page

Blank page

Blank page

45W
SMD SURGE PROTECTION RESISTOR
RNP-45

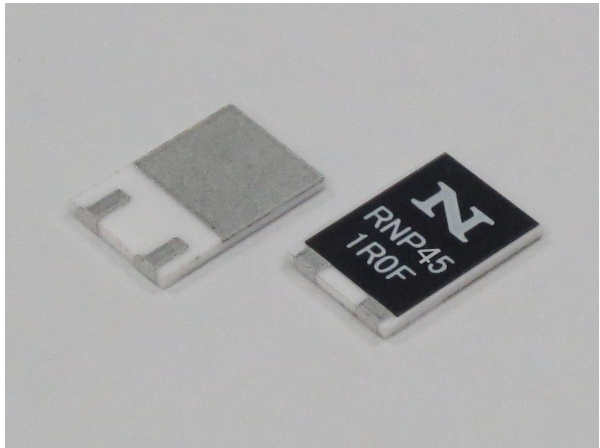

Features and Applications

- Very small size, low profile, right weight SMD surge protection power film resistors.
- 55°C to +175°C temperature range provides for automotive applications.
- Low thermal resistance under 3.0 °C/W shows excellent cooling performance.
- Easy to replace D-PAK power resistor.
- Excellent rf characteristics advantage to high speed pulse operation.
- Applications include snubber, gate control, bleeder, filter, rush current protection, braking resistors of automotive, rail traction, wind turbine, PV, UPS and motor control inverters.

Dimensions, Foot Pattern and Materials (mm)

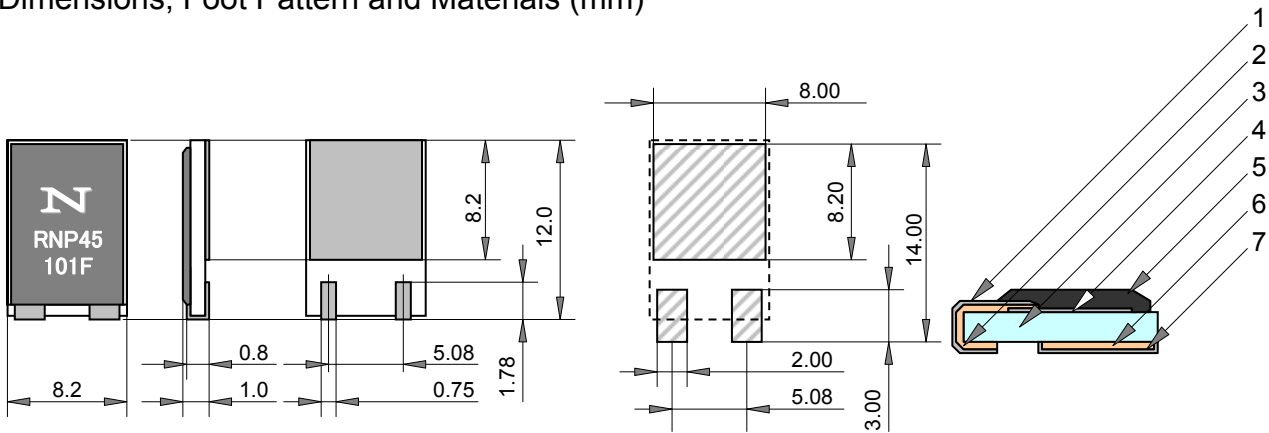

	substance	material
1	terminals	Pd-Ag film, Ni plating & Tin plating
2	terminals	Copper, Ni plating & Tin plating
3	substrate	ALO 1mm thickness
4	resistor	Ni-Cr alloy
5	molding	Epoxy resin, UL-94 V-0
6	heat sink	Pd-Ag film, Ni plating & Tin plating
7	heat sink	Pd-Ag film, Ni plating & Tin plating

Ordering Information

Type RNP-45	blank -	Resistance 100 Ohm	Tolerance F*	Code Z01	Remarks
RNP-45	-	0.02 Ohm- 510k Ohm E24+	F(1%)*	Z01	Tape reel

Recommend resistance E24+

1.0	1.1	1.2	1.3	1.5	1.6	1.8	2.0	2.2	2.4	2.5	2.7	3.0	3.3
3.6	3.9	4.0	4.3	4.7	5.0	5.1	5.6	6.2	6.8	7.5	8.0	8.2	9.1

(*) Tolerance of 0.02ohm to 0.091ohm will be +/-5% only.

45W SMD POWER CHIP RESISTOR, RNP-45

Specifications

	RNP-45	Test Conditions
Rating Power	45 Watts	-55 °C to 25 °C backing metal temperature
Rating Power	1.0 Watts	Attached on simple foot print.
Short Time Overload	50W	Rated power X 2.0 and 5 second at 25°C with heat-sink
Heat Resistance	3.0 °C/W	Resistor to back metal
Resistance Range	0.02 Ohm – 510k Ohm	0.02ohm-0.91ohm are available at 5% tolerance only.
Nominal	E24+	Include 2.5, 4.0, 5.0, 8.0 and 16
TCR	100 ppm/°C	10ohm to 51kohm, around 100 ppm/°C under 9.1ohm
Tolerance	+/-1% (F)	
Resistor Material	Thick Film	
Capacitance	2.65 pF	Equivalent parallel capacitance, typical
Inductance	14.65 nH	Equivalent series inductance, typical
Operation Temp.	-55 °C to +175 °C	
Max. Operating Current	10A	
Max. Operating Volt.	less than 500V or $\sqrt{P \cdot R}$	P is rating power and R resistance
Withstanding Volt.	1500 VAC	Terminal and back metal, 60 seconds. 1mA
Load Life	+/- 1.0 %	25 °C, 90 min. ON, 30 min. OFF, 1000h.
Humidity	+/- 1.0 %	40 °C, 90-95%RH, DC 0.1W, 1000 hours.
Temp. Cycle	+/- 0.25 %	-55 °C, 30 min., +155 °C, 30 min., 5cycle
Soldering Heat	+/- 0.1 %	350+/-5 °C, 3seconds,
Lead Solder ability	Over 95% of surface	230+/-5 °C, 3seconds.
Insulation Resistance	Over 1,000 Meg ohm	Between terminals and back metal.
Vibration	+/- 0.25 %	IEC60068-2-6, see note 4
Weight	0.324 gram	

Power Derating

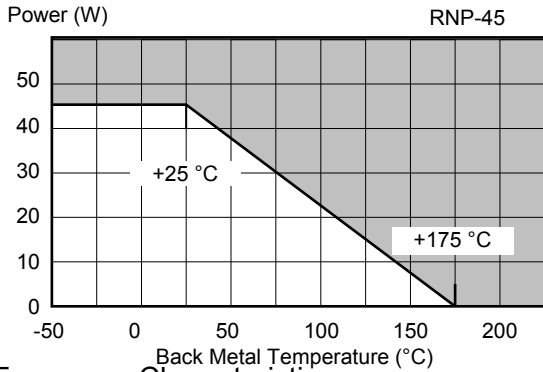

Pulse Energy Durability

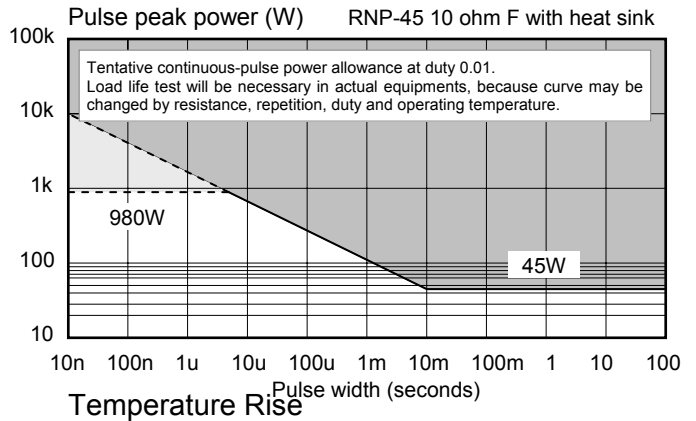

Frequency Characteristics

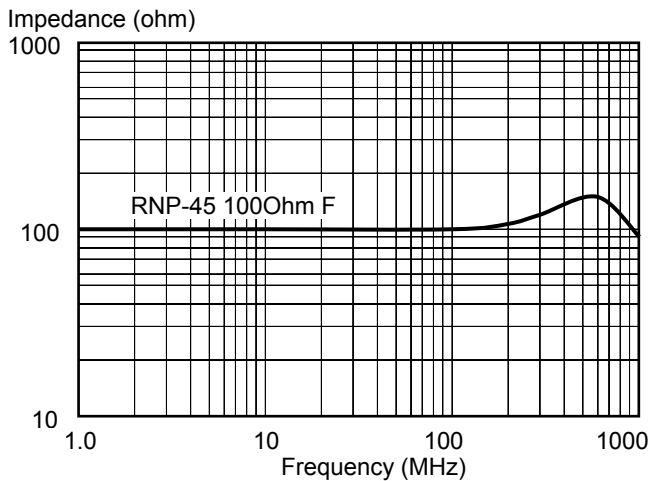

Temperature Rise

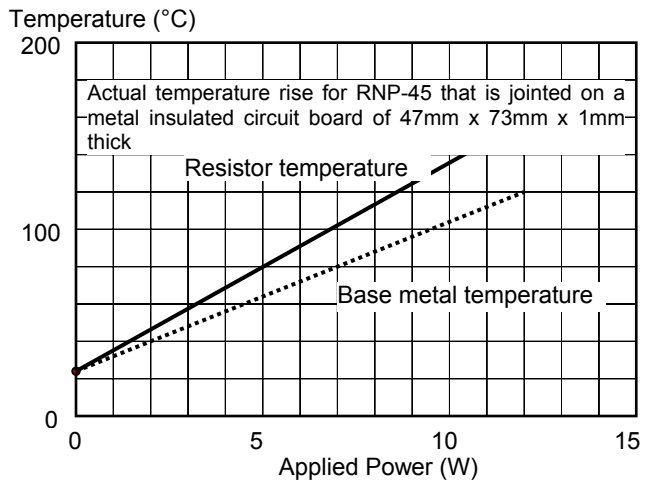

TO263 SURFACE MOUNT
35W HIGH POWER RESISTORS
RNP-20D, RNP-20E, RNP-20F

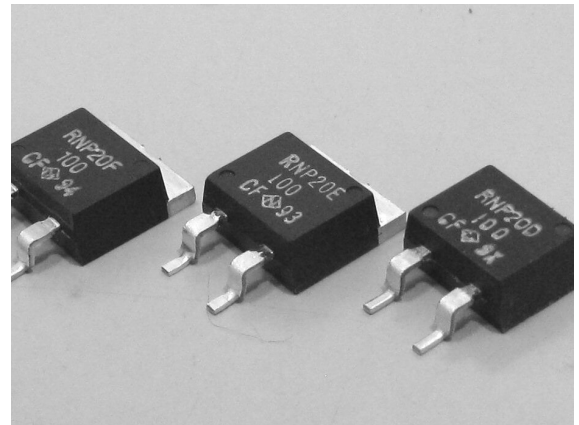

Features and Applications

35W high power resistors in TO263 (D2-PAK) style surface mount mold package with Nickel plated (RNP-20D), matte Tin plated (RNP-20E, RNP-20F) flange.
Non-inductive design suits high frequency applications and high-speed pulse circuits.
Low, 3.3 deg C/W heat resistance from resistor hot spot to flange and long life performance are presented with thin film metallization technology.
Wide, 10 mΩ to 51K Ω resistance range, non-inductive impedance characteristic and heat extracting through insulated metal flange aids circuit designers.
Applications for UPS, power unit of machines, motor control, drive circuits, automotive, measurements, industrial computers and high frequency electronics.

Dimensional Specifications (mm)

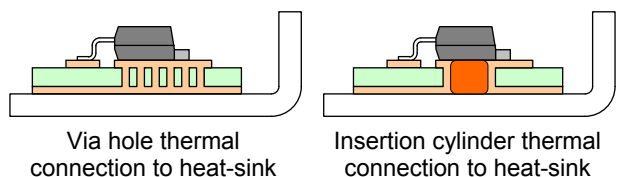
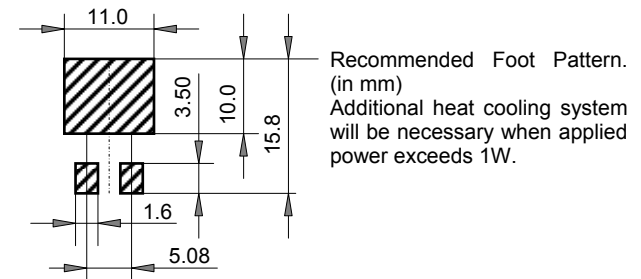
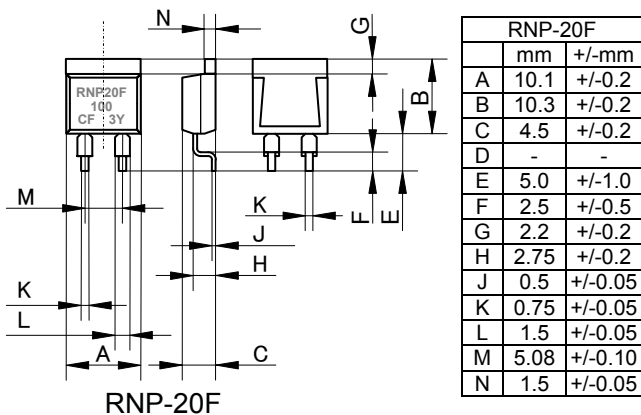
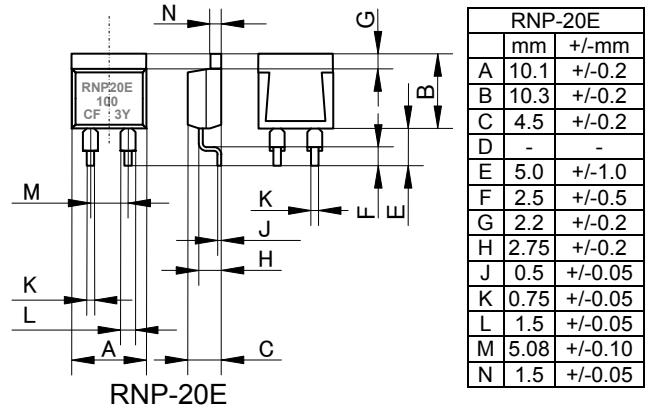
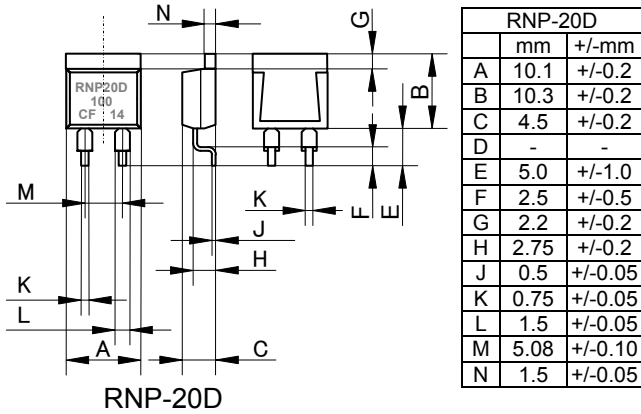

TO263 SURFACE MOUNT 35W HIGH POWER RESISTORS

RNP-20D, RNP-20E, RNP-20F

Materials and Reflow Temperature

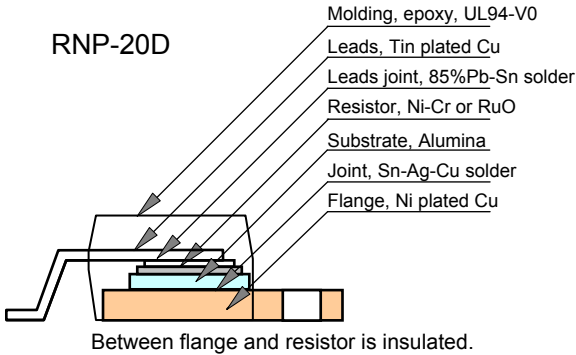

When joint on printed circuit board, reflow soldering by furnace with another parts shall not be recommended. After mounting another parts and after pre-coating solder on to land pattern, dip flange and leads in to soldering resin, place RNP-20D resistor on the land pattern, and heat flange for 20-30 seconds by soldering iron which iron tip temperature is 300-350 deg C. Flange temperature shall be in 270+/-10 deg C for 30 seconds. A better result will be obtained if flange is pre-coating solder. Please note using soldering flux and large caloric capacity.

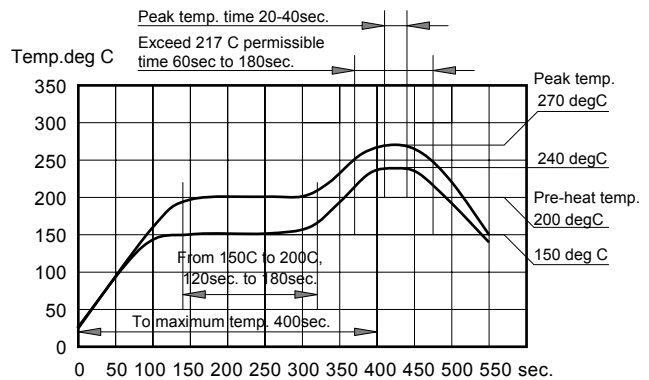
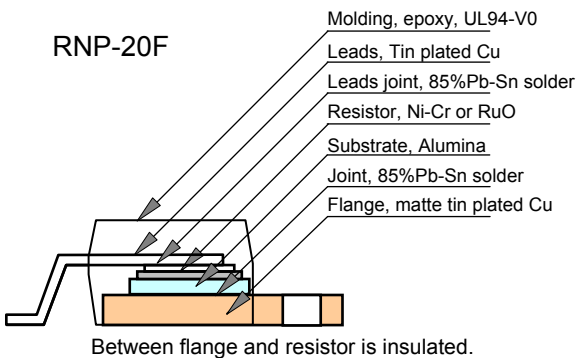
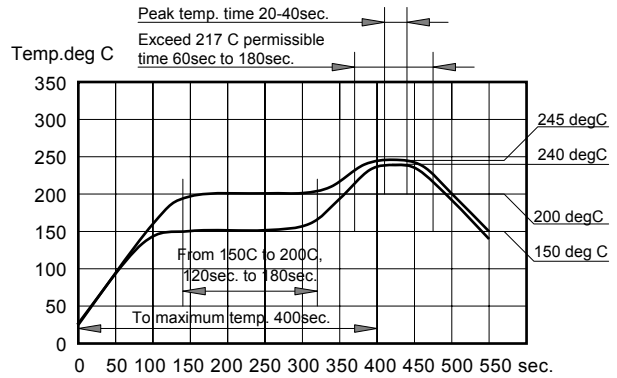
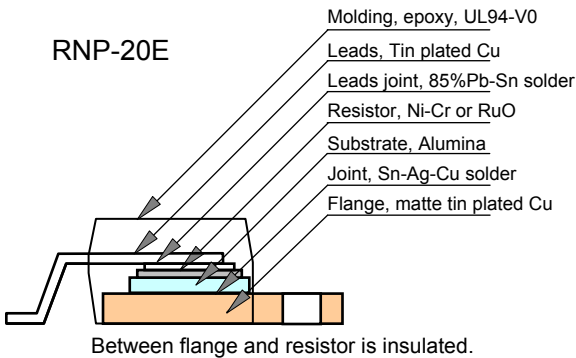

Ordering Information

Type	TCR	Resistance	Tolerance	Code	Note
RNP-20F	A	1R0 *(1)	F	Z01	Tape reel
RNP-20D	H(>250ppm)	R02 to 51K	J (5%)	Z01	Tape/500pcs
RNP-20E	A(100ppm)	E24+	F (1%)	Z03	Tube/50pcs
RNP-20F	C(50ppm)	R01-1% is option		Z05	Tray/100pcs

Resistance value (*) is available following modified E24 as E24+.

1.0	1.1	1.2	1.3	1.5	1.6	1.8	2.0	2.2	2.4	2.5	2.7	3.0	3.3
3.6	3.9	4.0	4.3	4.7	5.0	5.1	5.6	6.2	6.8	7.5	8.0	8.2	9.1

*1: E96 and any other resistances are available optionally, please call factory.

TO263 SURFACE MOUNT 35W HIGH POWER RESISTORS

RNP-20D, RNP-20E, RNP-20F

Specifications

Type	RNP-20D, RNP-20E, RNP-20F			Test Conditions
Rating Power	35 Watt			-55 deg C to 25 deg C flange temperature
Rating Power	1 Watt			Attached on simple foot print.
Heat Resistance	3.3 deg C/W			Resistor hot spot to flange
Resistance Range	0.02-0.091Ω	0.1-9.1Ω	10-51KΩ	Note 2
Nominal	E6	E24	E24	Include 2.5, 4.0, 5.0, 8.0 and 16
TCR (ppm/deg C)	250(H)	100 (A)	50 (C)	Note 3.
Tolerance	5%(J)	1% (F) 5% (J)	+/-1% (F)	1% tolerance at 0.01-0.091 Ω are available.
Capacitance	1.44pF			Equivalent parallel capacitance.
Inductance	8.38nH			Equivalent series inductance
Operation Temp.	-55 deg C to +155 deg C			
Operating Volt.	Either 500V or $\sqrt{P \cdot R}$			P is rating power and R resistance
Withstanding Volt.	2000 VAC			Terminal and flange, 60 seconds. 1mA
Load Life	+/- 1.0 %			25 deg C, 90 min.ON, 30 min. OFF, 1000h.
Humidity	+/- 1.0 %			40 deg C, 90-95%RH, DC 0.1W, 1000 hours.
Temp. Cycle	+/- 0.25 %			-55 deg C, 30 min., +155 deg C, 30 min., 5cyc
Soldering Heat	+/- 0.1 %			350 +/- 5 deg C, 3seconds,
Lead Solder ability	Over 95% of surface			230 +/- 5 deg C, 3seconds.
Insulation Resistance	Over 1,000 Meg Ω			Between terminals and tab.
Vibration	+/- 0.25 %			IEC60068-2-6, see note 4
Flammability	UL94-V0			
Weight	1.5 grams			

Power Derating

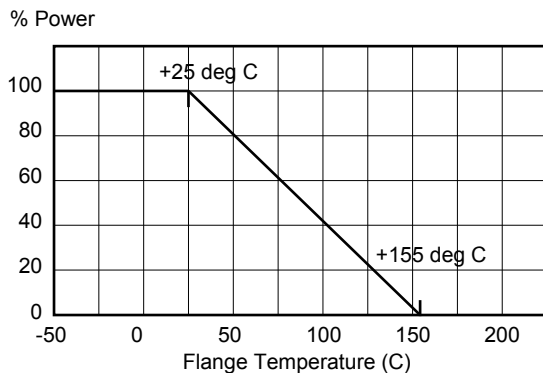

Pulse Energy Durability

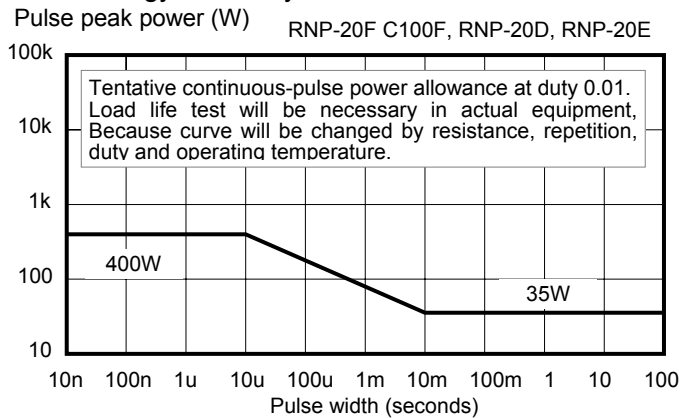

Tape Dimension

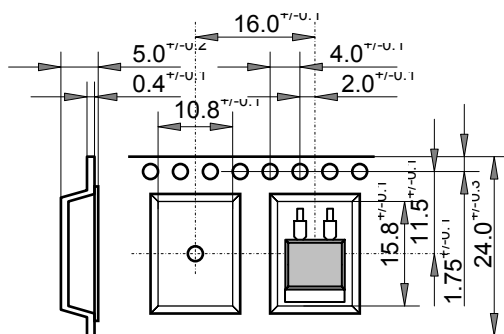

Reel Dimension

Outer diameter: 330 mm
 Inner diameter: 100 mm
 Width: 23.9 mm min. 27.4 mm max
 Package quantity: 500pcs/13 inches reel

Note:

- (1) Flange insulation is not necessary between flange and heat-sink, flange and resistor is separated by alumina substrate.
- (2) Resistance measurement shall be made at terminal foot portion.
- (3) TCR of low resistance will be increased as 300ppm/0.02Ω, 200ppm/0.05Ω, 140ppm/0.1Ω and 80ppm/0.2Ω typically. Testing point is at 5.27mm from bottom of moldings of terminals.
- (4) Test method is IEC60068-2-6, and specification is sine sweep wave form, 100Hz-2000Hz, 10 cycles, amplitude 0.75mm or 100m/s², 90minutes. direction x-y z, Amplitude 0.75mm will be applied under break point Frequency (about 60Hz) and 100m/ s² over break point
- (5) Standard packaging is tape reel, a tape reel contains 500pcs. when small quantity, tube packaging will be used, the tube is made by RoHS PS/PE which contains 50pcs / tube.

50W TO263 HIGH POWER RESISTORS
(D2PAK)
RNP-50E

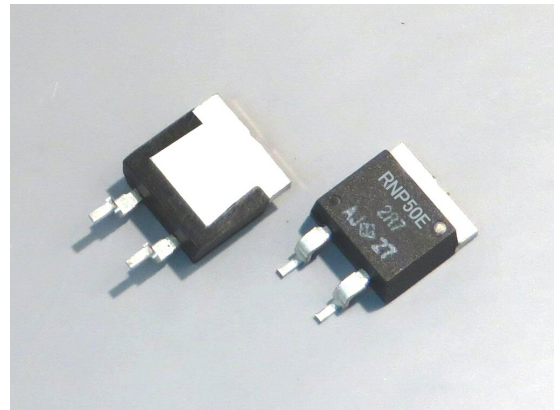

Features and Applications

TO263 (D2PAK) 50W surface mount high power resistors.
 Non-inductive design suits for automotive electronics, high frequency applications and high-speed pulse circuits.
 Thin film metalize technology presents lowest 2.3 °C/W heat resistance from resistor to flange
 Wide, 20mΩ to 510kΩ resistance range, non-inductive impedance characteristic and heat venting through insulated metal flange aids circuit designers.
 Small size and thin profile suits for high-density compact installations.
 Complete thermal conduction, heat dissipation design and vibration durable design to be easy.
 Applications include snubber, gate control, bleeder, filter, rush current protection, braking resistors of automotive, rail traction, wind turbine, PV, UPS and motor control inverters.

Dimensional Specifications (mm)

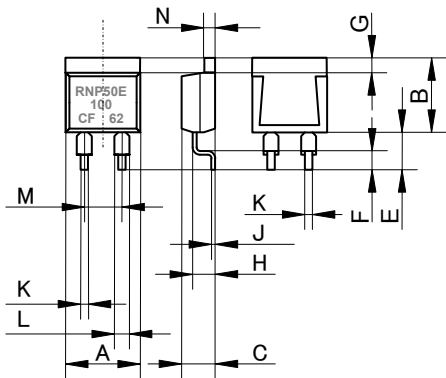

RNP-20E		
	mm	+/-mm
A	10.1	+/-0.2
B	10.3	+/-0.2
C	4.5	+/-0.2
D	-	-
E	5.0	+/-1.0
F	2.5	+/-0.5
G	2.2	+/-0.2
H	2.75	+/-0.2
J	0.5	+/-0.05
K	0.75	+/-0.05
L	1.5	+/-0.05
M	5.08	+/-0.10
N	1.5	+/-0.05

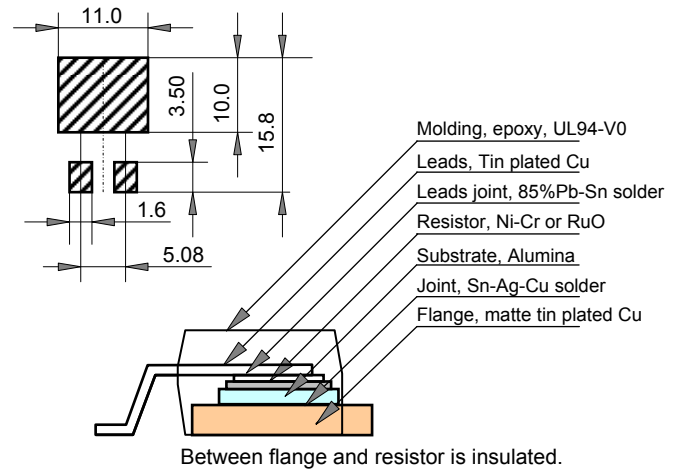

Ordering Information

RNP-50E	C	10R0 (*)	F	Z01	Note Tape & reel 50pcs / tube
RNP-50E	H (>250ppm)	R02-R09 (+E6)	J(5%)	Z01	
	A (100ppm)	R10-510K(+E24)	F(1%), J(5%)	Z03	
	C (50ppm)	10R-51K (+E24)	F(1%)		

Resistance value (*) is available following modified E24, +E24.

1.0	1.1	1.2	1.3	1.5	1.6	1.8	2.0	2.2	2.4	2.5	2.7	3.0	3.3
3.6	3.9	4.0	4.3	4.7	5.0	5.1	5.6	6.2	6.8	7.5	8.0	8.2	9.1

Note*: When ordering, additional ohm resistance notation is recommended for keeping out of misunderstanding.

Note:

- Resistance measurement shall be made at a point 5.27mm +/-0.6 mm from the resistor body.
- TCR of low resistance will be increased as 300ppm/0.02Ω, 200ppm/0.05Ω, 140ppm/0.1Ω and 80ppm/0.2Ω typically. Testing point is at 5.27mm from bottom of molding of terminals.
- Test method is IEC60068-2-6, and specification is sine sweep wave form, 100Hz-2000Hz, 10 cycles, amplitude 0.75mm or 100m/s², 90minutes. direction x-y-z. Amplitude 0.75mm will be applied under break point Frequency (about 60Hz) and 100m/ s² over break point
- Standard packaging is anti-static PE tape and reel, reel contains 500pcs/reel.

50W TO263 (D2PAK) HIGH POWER RESISTORS

RNP-50E

Specifications

Rated Power	50 Watt			-55 °C to 25 °C flange temperature
Rating Power	1 Watt			Free air.
Heat Resistance	2.3 °C/W			Hot spot to flange
Resistance Range	0.02-0.091 Ohm	0.1-510 k Ohm	10-51K Ohm	
Nominal Resistance	E6	E24+	E24	Include 2.5, 4.0, 5.0, 8.0 and 16
TCR (ppm/deg C)	250(H)	100 (A)	50 (C)	-55 °C to +155 °C
Tolerance	5%(J)	1% (F), 5% (J)	+/-1% (F)	Note 2
Resistor Material	Thick Film		Thin Film	
Capacitance	1.69pF			Equivalent parallel capacitance.
Inductance	9.65nH			Equivalent series inductance
Operation Temp. Range	-55°C to +175 °C			
Max. Operating Volt.	Small value either 700V or $\sqrt{P \times R}$			P is rating power and R resistance
Withstanding Voltage	2000 VAC			60 seconds. 1mA
Load Life	+/- 1.0 %			25 °C, 90 min. ON, 30 min. OFF, 1000 h.
Humidity	+/- 1.0 %			40 °C, 90-95%RH, DC 0.1W, 1000 h.
Temp. Cycle	+/- 0.25 %			-55 °C,30min.,+155°C,30min., 5cycles
Soldering Heat	+/- 0.1 %			350+/-5 °C, 3seconds,
Solder ability	Over 95% of surface			230+/-5 °C, 3seconds.
Insulation Resistance	Over 1,000 Meg Ω			Between terminals and flange.
Vibration	+/- 0.25 %			IEC60068-2-6, see note 4
Flammability	UL94V-0			
Weight	1.5 grams			

Derating

Rating Power (W)

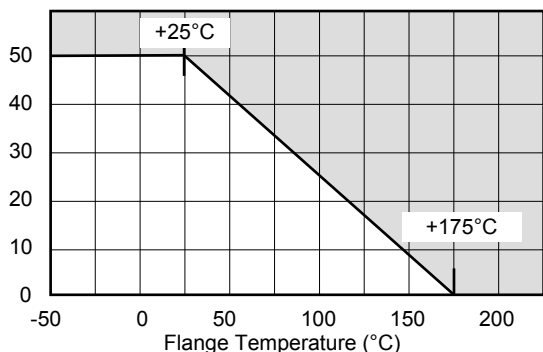

Temperature Rise

Temperature Rise (°C)

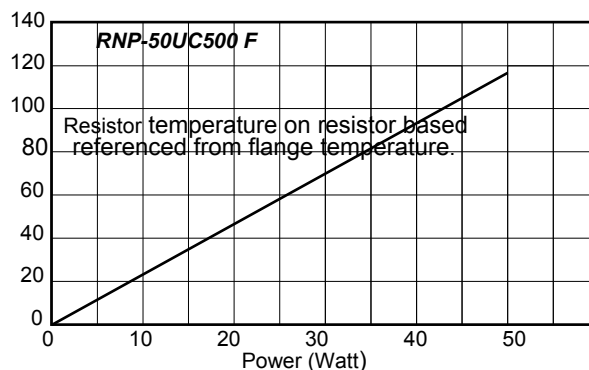

Pulse Durability

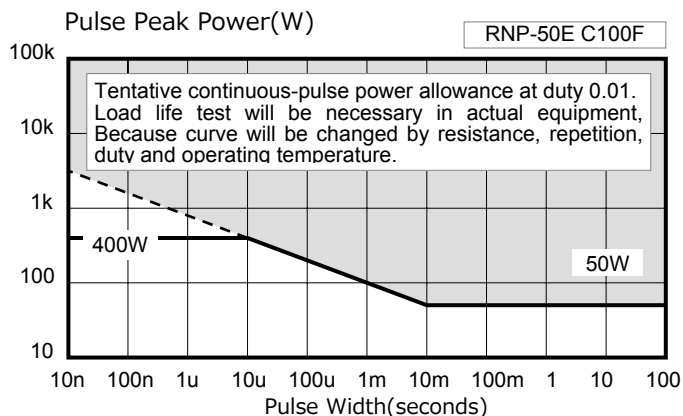

Frequency Characteristics

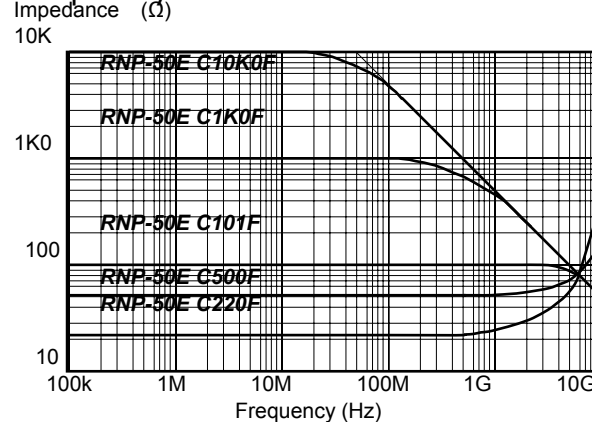

Note:

- Resistance measurement shall be made at a point 5.27mm +/-0.6 mm from the resistor body.
- TCR of low resistance will be increased as 300ppm/0.02Ω, 200ppm/0.05Ω, 140ppm/0.1Ω and 80ppm/0.2Ω typically. Testing point is at 5.27mm from bottom of molding of terminals.
- Test method is IEC60068-2-6, and specification is sine sweep wave form, 100Hz-2000Hz, 10 cycles, amplitude 0.75mm or 100m/s², 90minutes. direction x-y z, Amplitude 0.75mm will be applied under break point Frequency (about 60Hz) and 100m/ s² over break point
- Standard packaging is anti-static PE tape and reel, reel contains 500pcs/reel.

TO220 35W HIGH POWER RESISTORS
RMP-20S

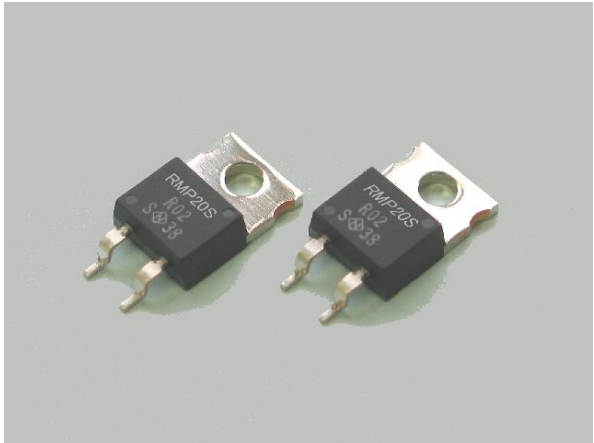

Features and Applications

35W high power resistors in TO220 style mold package for surface mount.
 Non-inductive design suits high frequency applications and high-speed pulse circuits.
 Low, 3.3 °C/W heat resistance from resistor hot spot to flange and long life performance are presented with thin film metallization technology and rejection of plastic adhesive joint.
 Wide 20 milliohm to 51kOhm resistance range, non-inductive impedance characteristic and heat conduction through the insulated metal flange aid circuit designers.
 Small size and thin profile suit high-density compact installations.
 Complete thermal conduction, heat dissipation design and vibration durable design also available.
 Applications include snubber, gate control, bleeder, filter, rush current protection, braking resistors of automotive, rail traction, wind turbine, PV, UPS and motor control inverters.

Dimensional Specifications (mm)

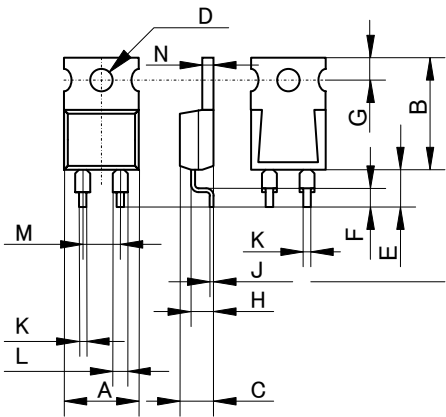

RMP-20S		
	mm	+/-mm
A	10.1	+/-0.2
B	15.0	+/-0.2
C	4.5	+/-0.2
D	3.6	+/-0.1
E	5.0	+/-1.0
F	2.5	+/-0.5
G	3.0	+/-0.2
H	2.75	+/-0.2
J	0.5	+/-0.05
K	0.75	+/-0.05
L	1.5	+/-0.05
M	5.08	+/-0.10

Structure and Materials

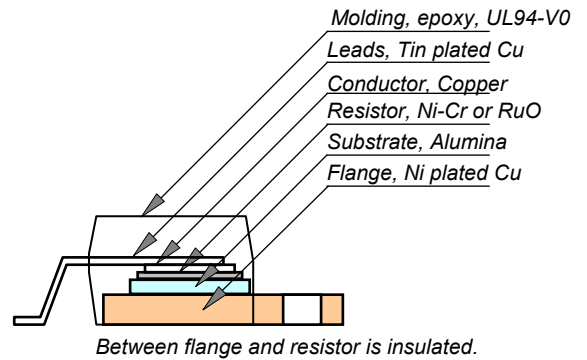

Ordering Information

RMP-20S	C	10R0 (*)	F	Z01	Note
RMP-20S	H(250ppm)	R02-R09 (+E6)	J(5%)	Z01	Tape/500pcs
	A(100ppm)	R10-510K(+E24)	F(1%), J(5%)	Z03	Tube/50pcs
	C(50ppm)	10R-51K (+E24)	F(1%)	Z05	Tray/100pcs

Resistance value (*) is available following modified E24, +E24.

1.0	1.1	1.2	1.3	1.5	1.6	1.8	2.0	2.2	2.4	2.5	2.7	3.0	3.3
3.6	3.9	4.0	4.3	4.7	5.0	5.1	5.6	6.2	6.8	7.5	8.0	8.2	9.1

Note*: When ordering, additional ohm resistance notation is recommended for keeping out of misunderstanding.

35W HIGH POWER RESISTORS

RMP-20S

Specifications

Type	RMP-20S			Test Conditions
Rating Power	35 W			-55 °C to 25 °C flange temperature
Rating Power	1 Watt			Free air.
Heat Resistance	3.3 ° C/W			Hot spot to flange
Resistance Range	0.01-0.091 Ohm	0.1-510 k Ohm	10-51k Ohm	Note 2
Nominal Resistance	E6	E24+	E24	Include 2.5, 4.0, 5.0, 8.0 and 16
TCR(ppm/° C)	250(H)*	100 (A)	50 (C)	Note 3
Tolerance	5%(J)	1% (F), 5% (J)	+/-1% (F)	1% tolerance at 0.01-0.091 ohm is available optionally.
	Thick Film		Thin Film	
Capacitance	1.44pF			Equivalent parallel capacitance.
Inductance	8.38nH			Equivalent series inductance
Operation Temp.	-55 °C to +175 °C			
Max. Operating Volt.	smaller value either 700V or $\sqrt{P \cdot R}$			P is rating power and R resistance
Withstanding Volt.	2000 VAC			Terminal and flange, 60 seconds, 1mA
Load Life	+/- 1.0 %			25 °C, 90 min. ON, 30 min. OFF, 1000 hours.
Humidity	+/- 1.0 %			40C, 90-95%RH, DC 0.1W, 1000 hours.
Temp. Cycle	+/- 0.25 %			-55 °C,30 min.,+155 °C,30 min., 5cycles
Soldering Heat	+/- 0.1 %			350+/-5 °C, 3seconds,
Solder ability	Over 95% of surface			230+/-5 °C, 3seconds.
Insulation Resistance	Over 1,000 Meg ohm			Between terminals and flange.
Vibration	+/- 0.25 %			IEC60068-2-6, see note 4
Weight	2.1 grams			

Derating

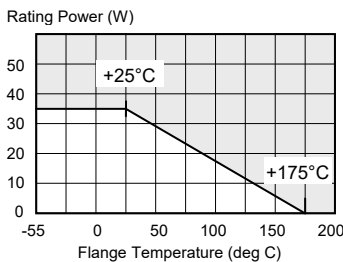

Temperature Rise

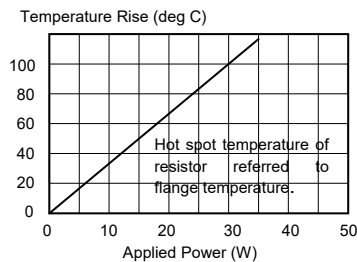

Typical TCR in Low Ohms

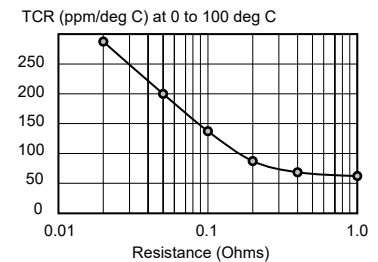

Pulse Energy Durability

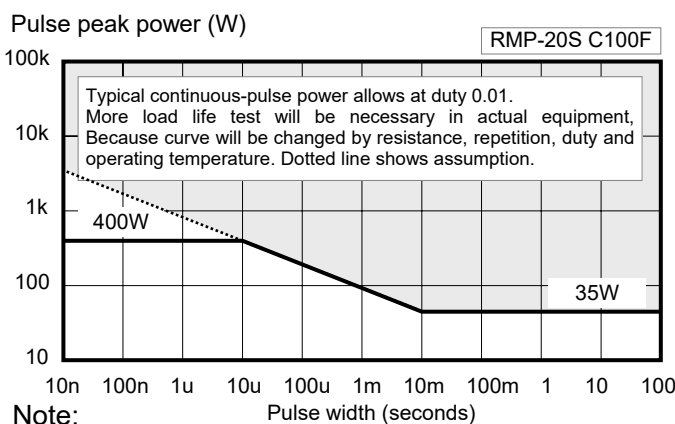

Frequency Characteristics

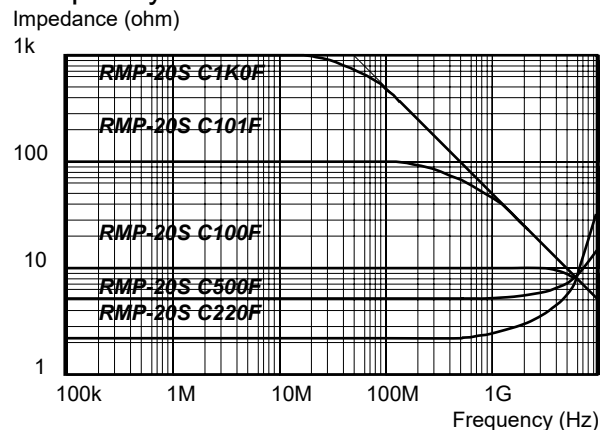

Note:

- Insulating material is unnecessary between flange and heat-sink, flange and resistor is separated by alumina substrate.
- Resistance measurement shall be made at a point 5.27mm +/-0.6 mm from the resistor body.
- TCR of low resistance will be increased as 300ppm/0.02ohm, 200ppm/0.05ohm, 140ppm/0.1ohm and 80ppm/0.2ohm typically. Testing point is at 5.27mm from bottom of molding of terminals.
- Test method is IEC60068-2-6, and specification is sine sweep wave form, 100Hz-2000Hz, 10 cycles, amplitude 0.75mm or 100m/s², 90minutes. direction x-y z, Amplitude 0.75mm will be applied under break point Frequency (about 60Hz) and 100m/ s² over break point
- When mounting resistor on heat-sink by screw, clip and pressure strip with using heat conduction grease on back side of resistor are recommended. Recommended screw torque is 0.5-0.6Nm.
- 0.1% tolerance resistors is available, please see datasheet of RNP-20P.
- Standard packaging is RoHS PS/PE tube packaging, which contains 50pcs / tube.

SMD 35W HIGH POWER RESISTORS

RMP-20S

Applications, RMP-20S

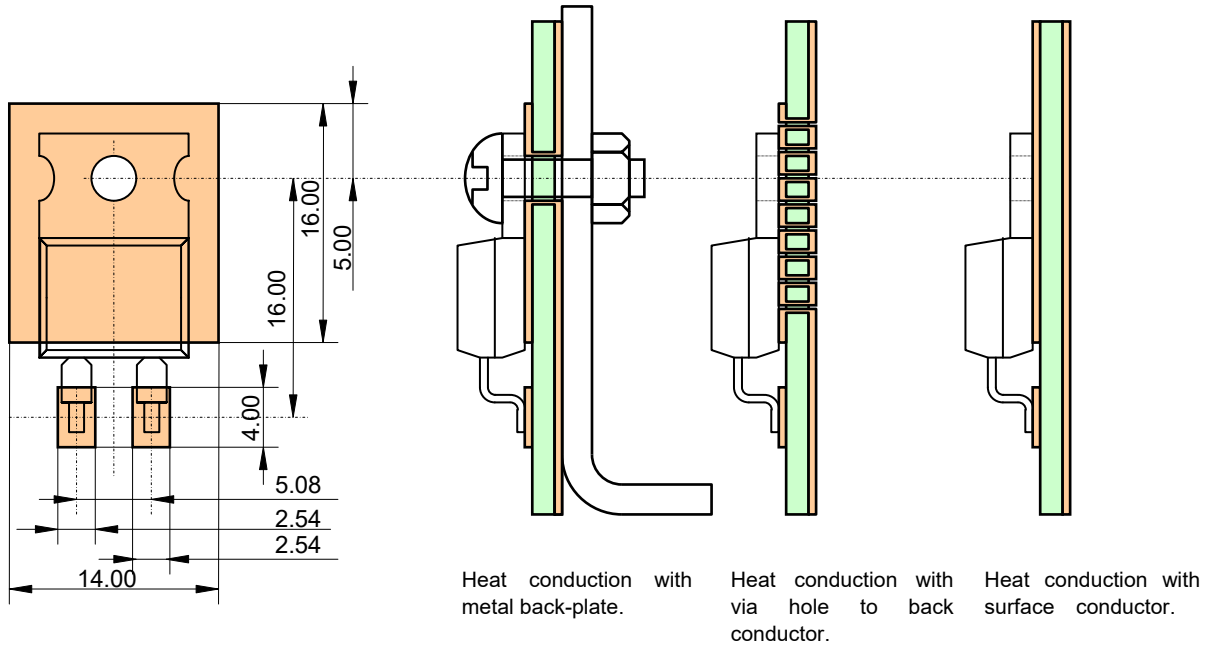

Tape Reel, RMP-20S (500pcs/reel)

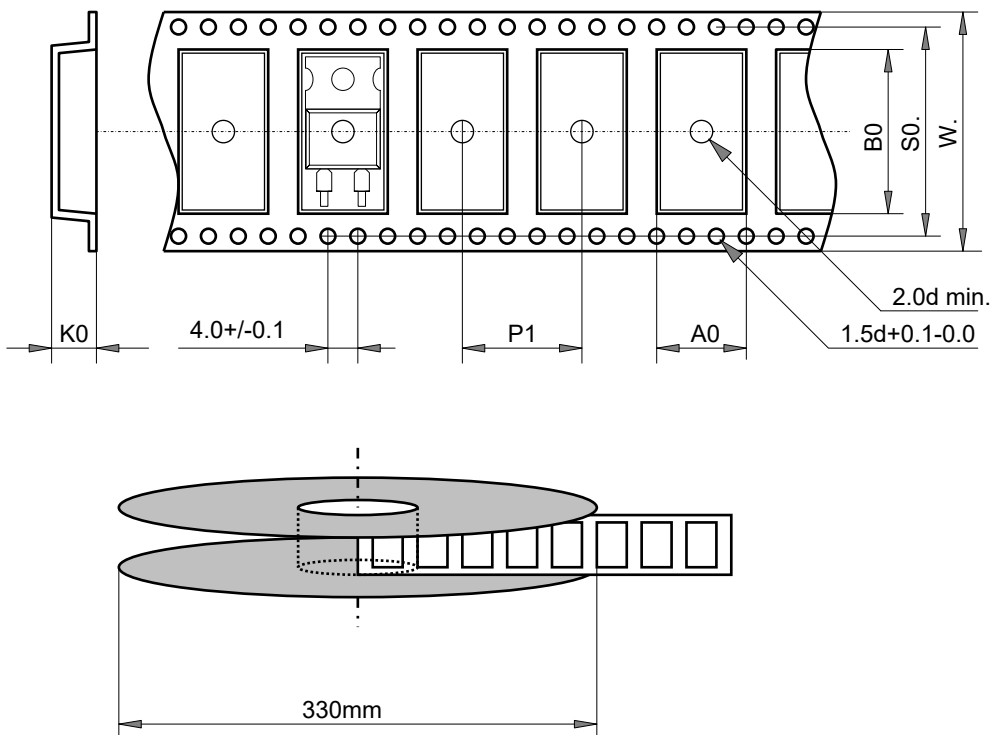

A0	10.56±0.1
B0	20.72±0.1
K0	6.10±0.1
P1	16.00±0.1
S0	28.40±0.1
W	32.00±0.3

TO220 50W HIGH POWER RESISTORS

RMP-50U

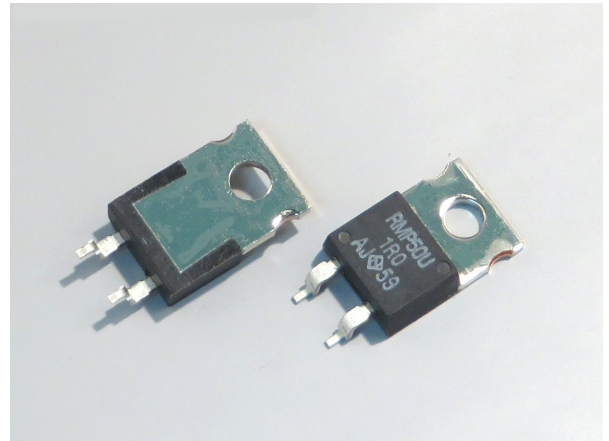

Features and Applications

50W high power resistors in TO220 style mold package for and screw mount.
 Non-inductive design suits high frequency applications and high-speed pulse circuits.
 Low, 2.3 deg °C/W heat resistance from resistor hot spot to flange and long life performance are presented with thin film metallization technology and rejection of plastic adhesive joint.
 Wide 20 milli Ohm to 510kOhm resistance range, non-inductive impedance characteristic and heat conduction through the insulated metal flange aids circuit designers.
 Small size and thin profile suit high-density compact installations.
 Complete thermal conduction, heat dissipation design and vibration durable design also available.
 Applications include snubber, gate control, bleeder, filter, rush current protection, braking resistors of automotive, rail traction, wind turbine, PV, UPS and motor control inverters.

Dimensional Specifications (mm)

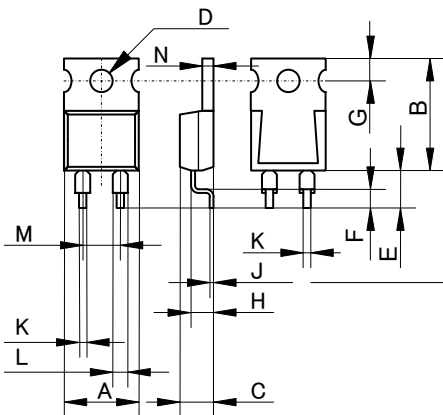

RMP-50U		
	mm	+/-mm
A	10.1	+/-0.2
B	15.0	+/-0.2
C	4.5	+/-0.2
D	3.6	+/-0.1
E	5.0	+/-1.0
F	2.5	+/-0.5
G	3.0	+/-0.2
H	2.75	+/-0.2
J	0.5	+/-0.05
K	0.75	+/-0.05
L	1.5	+/-0.05
M	5.08	+/-0.10
N	1.5	+/-0.05

Structure and Materials

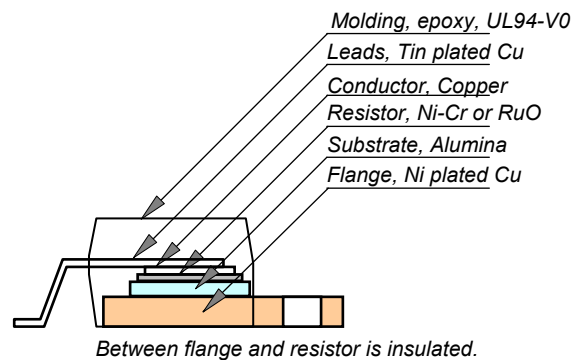

Ordering Information

RMP-50U	C	10R0 (*)	F	Z01	Note
RMP-50U	H (>250ppm) A (100ppm) C (50ppm)	> R02-R09 (+E6) > R10-510K(+E24) > 10R-51K (+E24)	> J(5%) > F(1%), J(5%) > F(1%)	Z01 Z03 Z05	> Tape reel/500pcs > Tube/50pcs > Tray/100pcs

Resistance value (*) is available following modified E24, +E24.

1.0	1.1	1.2	1.3	1.5	1.6	1.8	2.0	2.2	2.4	2.5	2.7	3.0	3.3
3.6	3.9	4.0	4.3	4.7	5.0	5.1	5.6	6.2	6.8	7.5	8.0	8.2	9.1

Note*: When ordering, additional ohm resistance notation is recommended for keeping out of misunderstanding.

TO220 50W HIGH POWER RESISTORS

RMP-50U

Specifications

	RMP-50U			Test Conditions
Rated Power	50 Watt			-55 °C to 25 °C flange temperature
Rating Power	1 Watt			Free air.
Heat Resistance	2.3 °C/W			Hot spot to flange
Resistance Range	0.02-0.09 Ohm	0.1-510 k Ohm	10-51K Ohm	Note 2
Nominal Resistance	E6	E24+	E24	Include 2.5, 4.0, 5.0, 8.0 and 16
TCR, ppm/deg C	250(H)	100 (A)	50 (C)	Note 3
Tolerance	5%(J)	1% (F), 5% (J)	+/-1% (F)	1% tolerance at 0.01-0.091 ohm is available optionally.
Resistor Material	Thick Film		Thin Film	
Capacitance	1.69pF			Equivalent parallel capacitance.
Inductance	9.65nH			Equivalent series inductance
Operation Temp.	-55 °C to +175 °C			
Max. Operating Volt.	smaller either 700V or $\sqrt{P \times R}$			P is rating power and R resistance
Withstanding Voltage	2000VAC			Terminal and flange, 60 seconds, 1mA
Load Life	+/- 1.0 %			25 °C, 90 min. ON, 30 min. OFF, 1000 hours.
Humidity	+/- 1.0 %			40 °C, 90-95%RH, DC 0.1W, 1000 hours.
Temp. Cycle	+/- 0.25 %			-55 °C,30 min.,+155 deg C,30 min., 5cycles
Soldering Heat	+/- 0.1 %			350+/-5 °C, 3seconds.
Solder ability	Over 95% of surface			230+/-5 °C, 3seconds.
Insulation Resistance	Over 1,000 Meg ohm			Between terminals and flange.
Vibration	+/- 0.25 %			IEC60068-2-6, see note 4
Weight	2.1 grams			

Derating

Rating Power (W)

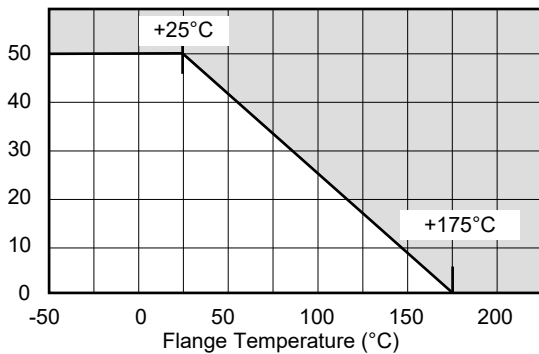

Temperature Rise

Temperature Rise (deg C)

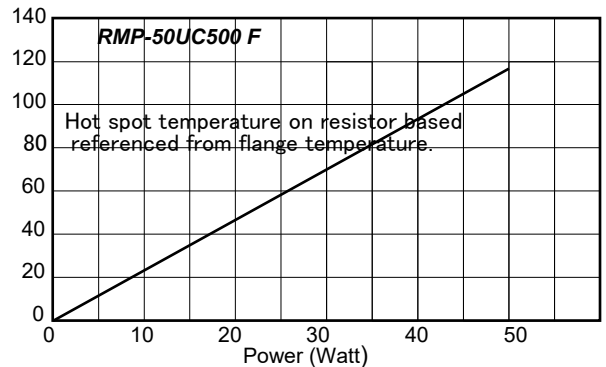

Pulse Durability

Pulse Peak Power(W)

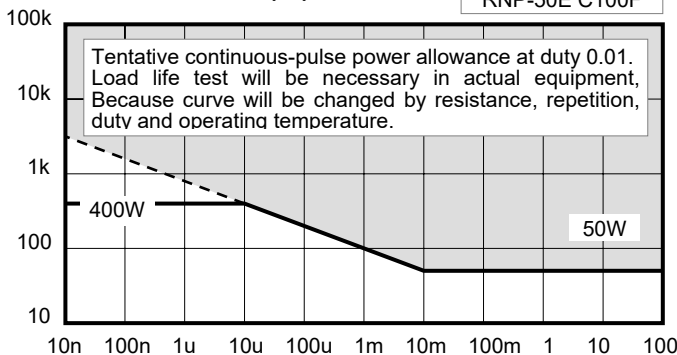

Frequency Characteristics

Impedance (ohm)

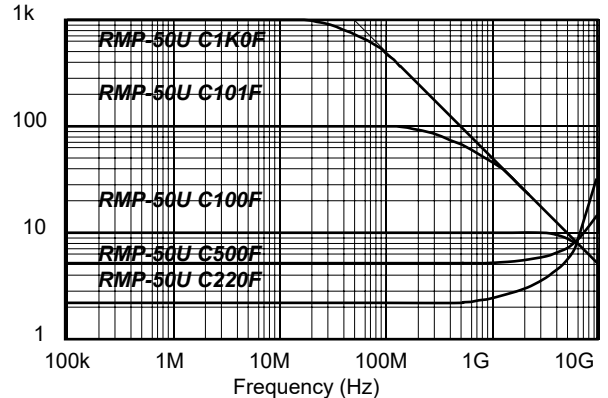

Note:

- Insulation material is unnecessary between flange and heat-sink, flange and resistor is separated by alumina substrate.
- Resistance measurement shall be made at a point 5.27mm +/-0.6 mm from the resistor body.
- TCR of low resistance will be increased as 300ppm/0.02ohm, 200ppm/0.05ohm, 140ppm/0.1ohm and 80ppm/0.2ohm typically. Testing point is at 5.27mm from bottom of molding of terminals.
- Test method is IEC60068-2-6, and specification is sine sweep wave form, 100Hz-2000Hz, 10 cycles, amplitude 0.75mm or 100m/s², 90minutes. direction x-y z, Amplitude 0.75mm will be applied under break point Frequency (about 60Hz) and 100m/ s² over break point
- When mounting resistor on heat-sink by screw, clip and pressure strip with using heat conduction grease on back side of resistor are recommended. Recommended screw torque is 0.5-0.6Nm.
- Standard packaging is anti-static PE tray, which contains 100pcs / tray.

20161101

TO126 20W HIGH POWER RESISTORS

RNP-10S

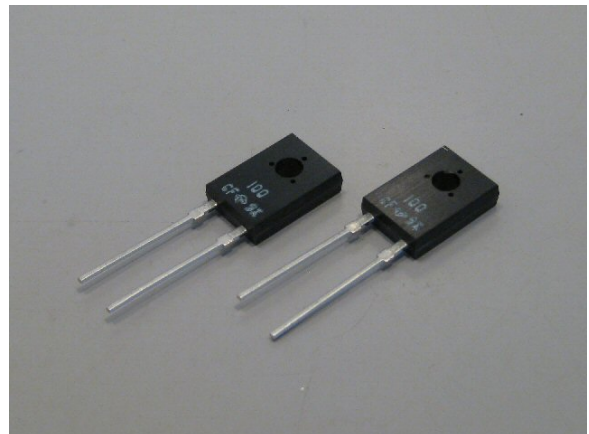

Features and Applications

Small size 20W high power resistors in TO126 style molded package.
 Non-inductive design suits high frequency applications and high-speed pulse circuits.
 Low, 5.9 C/W heat resistance from resistor hot spot to flange and long life performance are presented by thin film metallization technology and rejection of plastic adhesive joint.
 Wide 100 milliohm to 51KOhm resistance range, non-inductive impedance characteristic and heat conduction through the insulated metal flange aid circuit designers.
 Small size and thin profile suit high-density compact installations.
 Complete thermal conduction, heat dissipation design and vibration durable design also available.
 Applications for UPS, power unit of machines, motor control, drive circuits, automotive, measurements, industrial computers and high frequency electronics.

Dimension

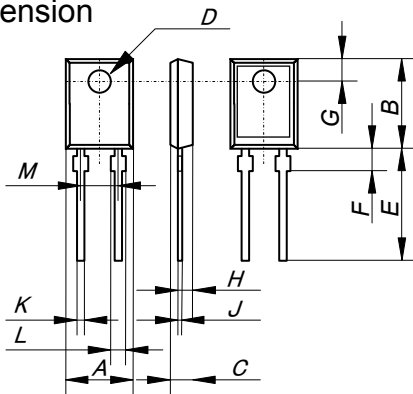

RNP-10S		
	mm	+/-mm
A	8.5	+/-0.2
B	12.0	+/-0.2
C	3.1	+/-0.2
D	3.1	+/-0.1
E	17.0	+/-1.0
F	3.2	+/-0.5
G	3.8	+/-0.2
H	1.75	+/-0.1
J	0.5	+/-0.05
K	0.6	+/-0.05
L	1.4	+/-0.05
M	5.08	+/-0.1

Materials

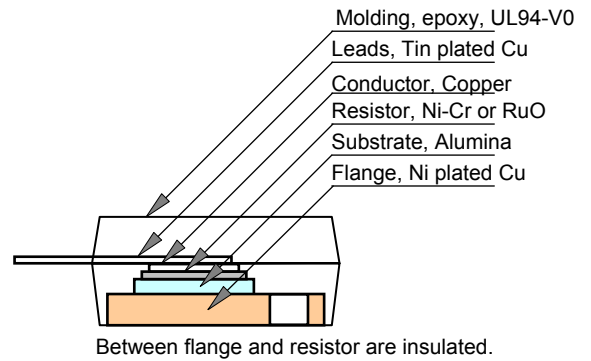

Specifications and Performances

Items	Specification-Performance			Test Conditions
Rating Power	20 Watts			At flange temperature of -55 C to +25 deg C
Rating Power	1 Watt			Free air (without heat sink).
Hear resistance	5.9 deg C/W			From hot spot to flange.
Resistance Range	0.01-0.09	0.1-9.1ohm	10-51Kohm	Note 2.
Nominal Resistance	E6	E24	E24	Includes 2.5, 4.0, 5.0, 8.0 and 16
TCR, ppm/deg C	+/-250 (H*)	+/-100 (A*)	+/-50 (C)	Note 3
Tolerance	+/-5%(J)	+/-1%(F), 5%(J)	+/-1%(F)	1% tolerance at 0.01-0.091 ohm are available optionally.
Capacitance	1.00 pF			Equivalent parallel capacitance.
Inductance	8.22 nH			Equivalent series inductance
Operation Temp. Range	-55 deg C to +155deg C			
Max. Operation Voltage	smaller value either 500V or $\sqrt{P \times R}$			P: rating power and R: resistance
Withstanding Voltage	2000 Volt AC			60 seconds, 1mA, between terminals and flange.
Load Life	+/-1.0 %			25 deg C, 90 min.ON, 30min.OFF, 1000hours.
Humidity	+/-1.0 %			40 deg C, 90 to 95%RH, DC0.1W, 1000hours.
Soldering Heat	+/-1.0 %			350+/-5 deg C, 3seconds,
Solder ability	Over 95 of surface			230+/-5 deg C, 3seconds.
Insulation Resistance	Over 1000 Meg ohm			Between terminals and flange.
Vibration	+/-0.25 %			IEC60068-2-6, see note 4
Weight	0.9 grams			

TO126 20W HIGH POWER RESISTORS

RNP-10S

Ordering Information

RNP-10S	C	10R0 (*)	F	Z00	Note
RNP-10S	H(250ppm)	R02-R09 (+E6)	J(5%)	Z03	Tube/60pcs
	A(100ppm)	R10-9R1 (+E24)	F(1%), J(5%)		
	C(50ppm)	10R-51K (+E24)	F(1%)		

Resistance value (*) is available following modified E24, +E24.

1.0	1.1	1.2	1.3	1.5	1.6	1.8	2.0	2.2	2.4	2.5	2.7	3.0	3.3
3.6	3.9	4.0	4.3	4.7	5.0	5.1	5.6	6.2	6.8	7.5	8.0	8.2	9.1

Note*: When ordering, additional ohm resistance notation is recommended for keeping out of misunderstanding.

Derating Curve

Rating Power(W), with 2.8 deg C/W heat sink.

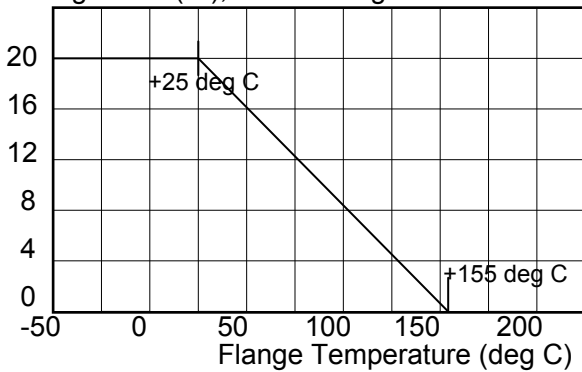

Temperature Rise at Flange Temperature (deg C)

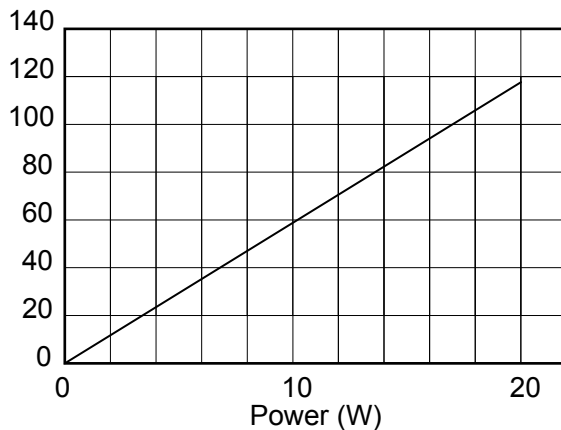

Frequency Characteristics

Impedance (ohm)

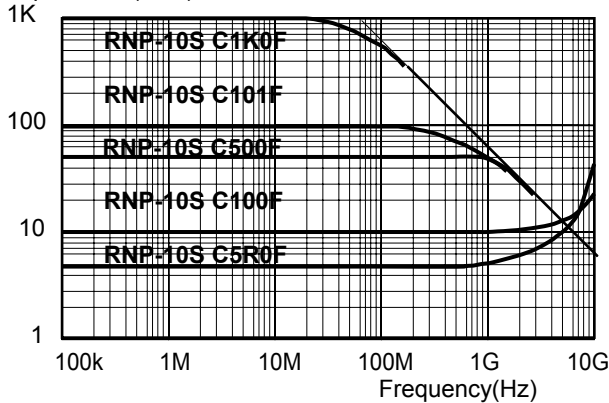

Pulse Energy Durability

Pulse peak power (W)

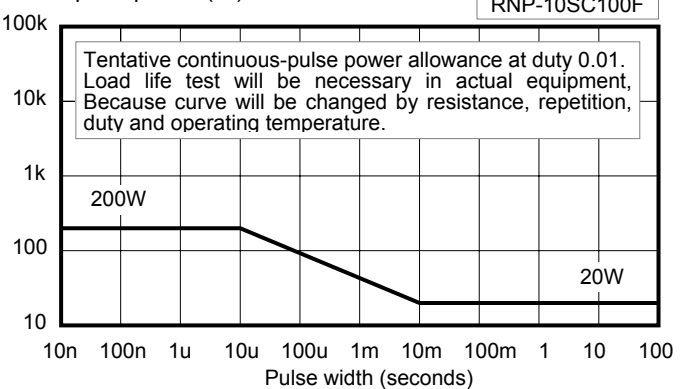

Notes

- (1) Insulation material is unnecessary between flange and heat-sink, because flange and resistor are separated by alumina insulated substrate. When mounting resistor on heat-sink, screw, clip and pressure strip with using heat conduction grease on back side of resistor are recommended. Recommended screw torque is 0.5-0.6Nm.
- (2) Resistance measurement shall be made at a point 5.27mm +/-0.6 mm from the resistor body.
- (3) TCR of low resistance will be increased as 300ppm/0.02ohm, 200ppm/0.05ohm, 140ppm/0.1ohm and 80ppm/0.2ohm typically. Testing point is at 5.27mm from bottom of molding of terminals.
- (4) Test method is IEC60068-2-6, and specification is sine sweep wave form, 100Hz-2000Hz, 10 cycles, amplitude 0.75mm or 100m/s², 90minutes. direction x-y z, Amplitude 0.75mm will be applied under break point Frequency (about 60Hz) and 100m/ s² over break point
- (5) When mounting resistor on heat-sink by screw, clip and pressure strip with using heat conduction grease on back side of resistor are recommended. Recommended screw torque is 0.5-0.6Nm.
- (6) 0.1% tolerance resistors is available, please see datasheet of RNP-10P.

20120401

TO220 20W HIGH POWER RESISTORS
RNP-10

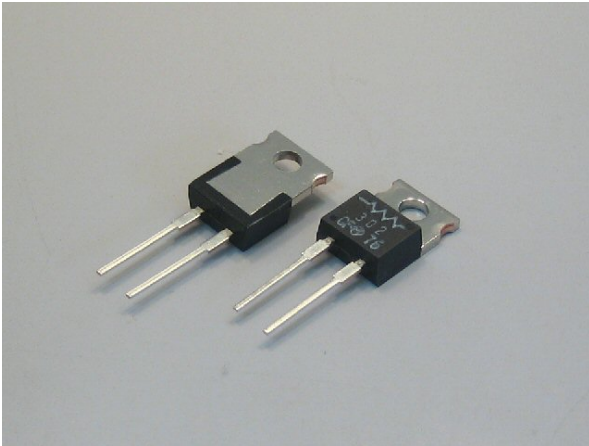

Features and Applications

20W high power resistors in TO220 style molded package for through-hole (20W) and surface mount (10W).

Non-inductive design suits high frequency applications and high-speed pulse circuits.

Low, 5.9 deg C/W heat resistance from resistor hot spot to flange and long life performance are presented with thin film metallization technology and rejection of plastic adhesive joint.

Wide 100 milliohm to 51KOhm resistance range, non-inductive impedance characteristic and heat conduction through the insulated metal flange aid circuit designers.

Small size and thin profile suit high-density compact installations.

Complete thermal conduction, heat dissipation design and vibration durable design also available.

Applications for UPS, power unit of machines, motor control, drive circuits, automotive, measurements, industrial computers and high frequency electronics.

Dimensions (mm)

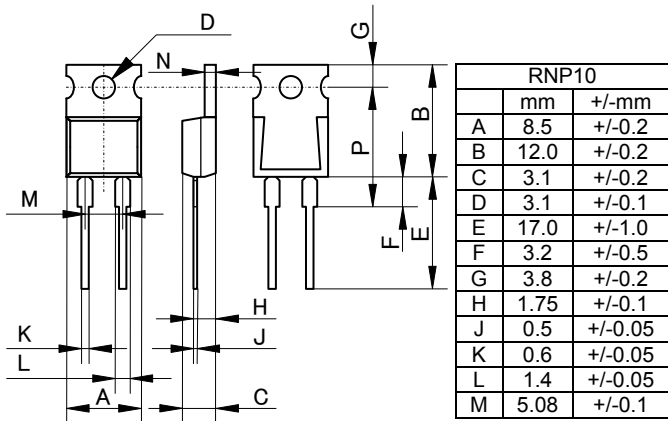

Structure and Material

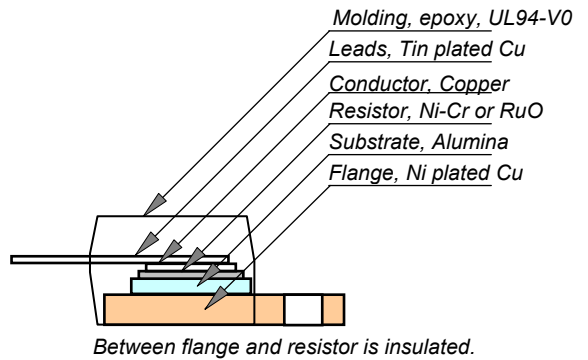

Ordering Information

RNP-10	C	10R0 (*)	F	Z00	Note
RNP-10	H(250ppm)	R02-R09 (+E6)	J(5%)	Z03	Tube/50pcs
	A(100ppm)	R10-9R1 (+E24)	F(1%), J(5%)	Z05	Tray/100pcs
	C(50ppm)	10R-51K (+E24)	F(1%)		

Resistance value (*) is available following modified E24, +E24.

1.0	1.1	1.2	1.3	1.5	1.6	1.8	2.0	2.2	2.4	2.5	2.7	3.0	3.3
3.6	3.9	4.0	4.3	4.7	5.0	5.1	5.6	6.2	6.8	7.5	8.0	8.2	9.1

Note*: When ordering, additional ohm resistance notation is recommended for keeping out of misunderstanding.

20W HIGH POWER RESISTORS

RNP-10

Specifications

Items	RNP-10		RMP-10	Test Conditions
Rating Power	20 W		10W	-55 to 25 deg C flange temperature
Rating Power	1 W		1W	Free air.
Heat Resistance	5.9 deg C/W		5.9 deg C/W	From resistor hot spot to flange
Resistance Range	0.01-0.091ohm	0.1-9.1ohm	10-51kohm	Note 2
Nominal Resistance	E6	E24	E24	Includes 2.5, 4.0 and 5.0
TCR (ppm / deg C)	250(H)	100 (A)	50 (C)	Note 3
Tolerance	5%(J)	1%(F), 5% (J)	1% (F)	1% tolerance at 0.01-0.091 ohm are available optionally.
Capacitance	1.15pF			Equivalent parallel capacitance.
Inductance	8.38nH			Equivalent series inductance
Operation Temp. Range	-55 deg C to +155 deg C			
Max. Operating Volt.	smaller value either 500V or $\sqrt{P \cdot R}$			P: rating power and R: resistance
Withstanding Volt.	2000 VAC			60 seconds. 1mA
Load Life	+/- 1.0 %			25 deg C, 90 min .ON, 30 min .OFF, 1000 hours.
Humidity	+/- 1.0 %			40 deg C, 90-95%RH, DC 0.1W, 1000 hours.
Temp. Cycle	+/- 0.25 %			-55 deg C, 30 min., +155 deg C, 30 min., 5cycles
Soldering Heat	+/- 0.1 %			350+/-5 deg C, 3seconds,
Solder ability	Over 95% of surface			230+/-5 deg C, 3seconds.
Insulation Resistance	Over 1,000 Meg ohm			Between terminals and flange.
Vibration	+/- 0.25 %			IEC60068-2-6, see note 4
Weight	2.1 grams			

Derating

Power(W)

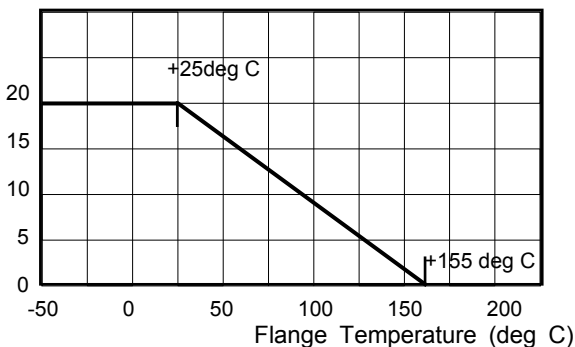

Temperature Rise

(C)

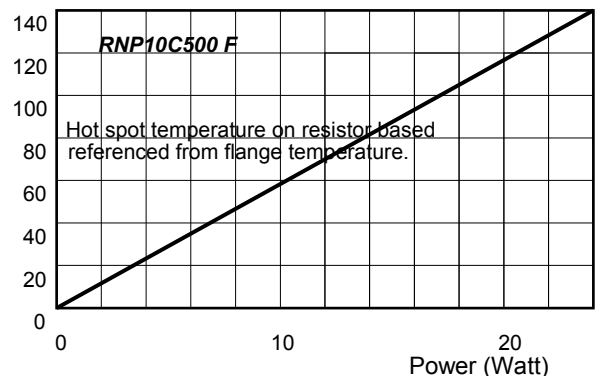

Pulse Energy Durability

Pulse peak power (W)

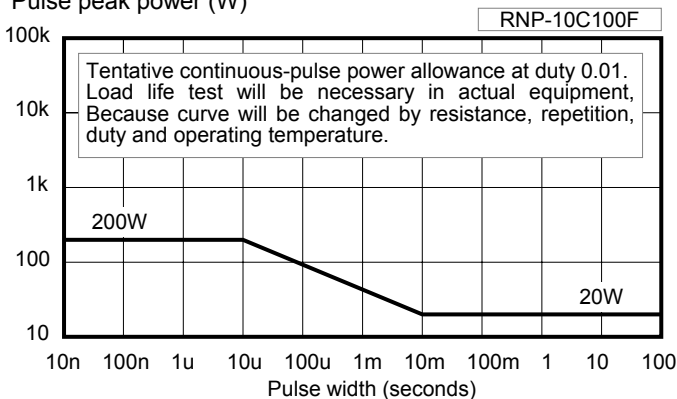

Frequency Characteristics

Impedance (ohm)

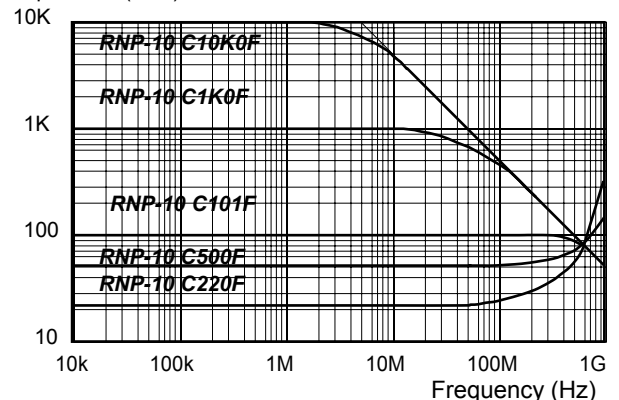

Note:

- Insulating material is unnecessary between flange and heat-sink, flange and resistor is separated by alumina substrate.
- Resistance measurement shall be made at a point 5.27mm +/-0.6 mm from the resistor body.
- TCR of low resistance will be increased as 300ppm/0.02ohm, 200ppm/0.05ohm, 140ppm/0.1ohm and 80ppm/0.2ohm typically. Testing point is at 5.27mm from bottom of molding of terminals.
- Test method is IEC60068-2-6, and specification is sine sweep wave form, 100Hz-2000Hz, 10 cycles, amplitude 0.75mm or 100m/s², 90minutes. direction x-y z, Amplitude 0.75mm will be applied under break point Frequency (about 60Hz) and 100m/ s² over break point
- When mounting resistor on heat-sink by screw, clip and pressure strip with using heat conduction grease on back side of resistor are recommended. Recommended screw torque is 0.5-0.6Nm.
- 0.1% tolerance resistors is available, please see datasheet of RNP-20P.

TO220 35W HIGH POWER RESISTORS
RNP-20S

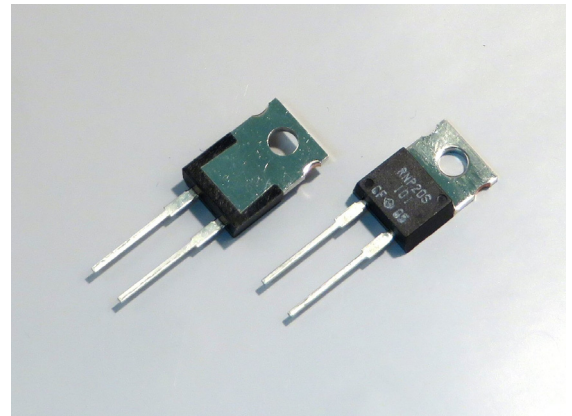

Features and Applications

35W high power resistors in TO220 style mold package for through-hole and surface mount. Non-inductive design suits high frequency applications and high-speed pulse circuits. Low, 3.3 °C/W heat resistance from resistor hot spot to flange and long life performance are presented with thin film metallization technology and rejection of plastic adhesive joint. Wide 100 milliohm to 51kOhm resistance range, non-inductive impedance characteristic and heat conduction through the insulated metal flange aid circuit designers. Small size and thin profile suit high-density compact installations. Complete thermal conduction, heat dissipation design and vibration durable design also available. Applications include snubber, gate control, bleeder, filter, rush current protection, braking resistors of automotive, rail traction, wind turbine, PV, UPS and motor control inverters.

Dimensional Specifications (mm)

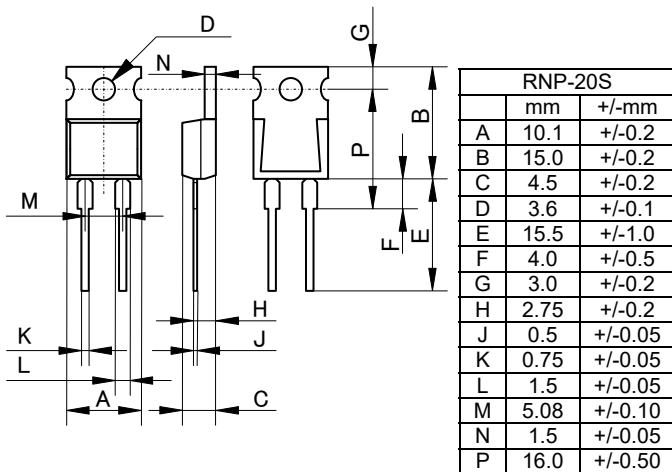

Structure and Material

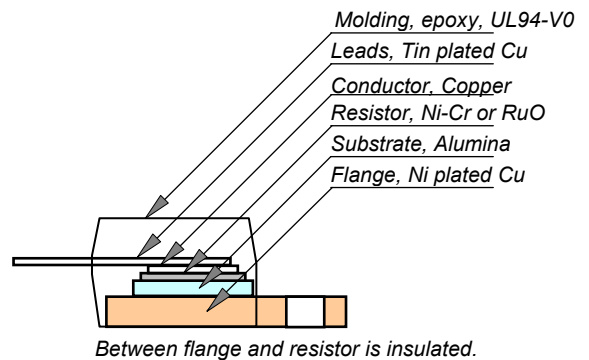

Ordering Information

RNP-20S	C	10R0 (*)	F	Z03	Note
RNP-20S	H(250ppm)	R02-R09 (+E6)	J(5%)	Z03	Tube
	A(100ppm)	R10-510K(+E24)	F(1%), J(5%)	Z05	Tray
	C(50ppm)	10R-51K (+E24)	F(1%)		

Resistance value (*) is available following modified E24, +E24.

1.0	1.1	1.2	1.3	1.5	1.6	1.8	2.0	2.2	2.4	2.5	2.7	3.0	3.3
3.6	3.9	4.0	4.3	4.7	5.0	5.1	5.6	6.2	6.8	7.5	8.0	8.2	9.1

Note*: When ordering, additional ohm resistance notation is recommended for keeping out of misunderstanding.

35W HIGH POWER RESISTORS

RNP-20S

Specifications

Type	RNP-20S			Test Conditions
Rating Power	35 W			-55 °C to 25 °C flange temperature
Rating Power	1 Watt			Free air.
Heat Resistance	3.3 °C/W			Heat resistance between hot spot and flange
Resistance Range	0.01-0.091 Ohm	0.1-510 k Ohm	10-51k Ohm	Note 2
Nominal Resistance	E6	E24+	E24	Include 2.5, 4.0, 5.0, 8.0 and 16
TCR(ppm/°C)	250(H)*	100 (A)	50 (C)	Note 3
Tolerance	5%(J)	1% (F), 5% (J)	+/-1% (F)	1% tolerance at 0.01-0.091 ohm is available optionally.
Resistor Material	Thick Film		Thin Film	
Capacitance	1.44pF			Equivalent parallel capacitance.
Inductance	8.38nH			Equivalent series inductance
Operation Temp.	-55 °C to +175 °C			
Max. Operating Volt.	smaller value either 500V or $\sqrt{P \cdot R}$			P is rating power and R resistance
Withstanding Volt.	2000 VAC			Terminal and flange, 60 seconds, 1mA
Load Life	+/- 1.0 %			25 °C, 90 min. ON, 30 min. OFF, 1000 hours.
Humidity	+/- 1.0 %			40C, 90-95%RH, DC 0.1W, 1000 hours.
Temp. Cycle	+/- 0.25 %			-55 °C,30 min.,+155 °C,30 min., 5cycles
Soldering Heat	+/- 0.1 %			350+/-5 °C, 3seconds,
Solder ability	Over 95% of surface			230+/-5 °C, 3seconds.
Insulation Resistance	Over 1,000 Meg ohm			Between terminals and flange.
Vibration	+/- 0.25 %			IEC60068-2-6, see note 4
Weight	2.1 grams			

Derating

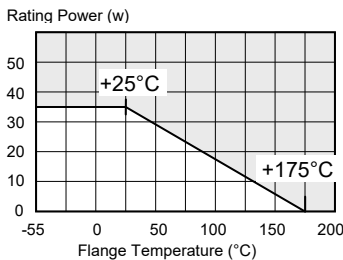

Temperature Rise

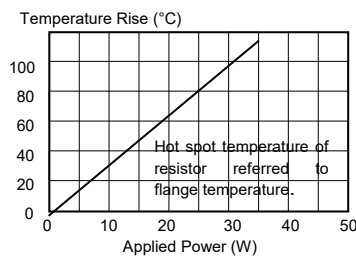

Typical TCR in Low Ohms

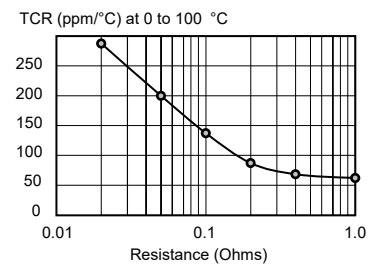

Pulse Energy Durability

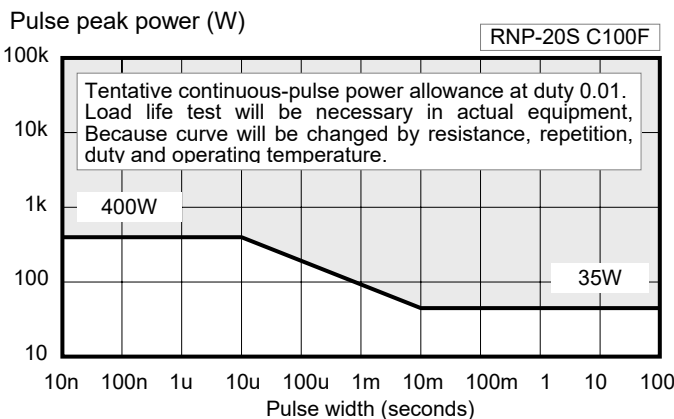

Frequency Characteristics

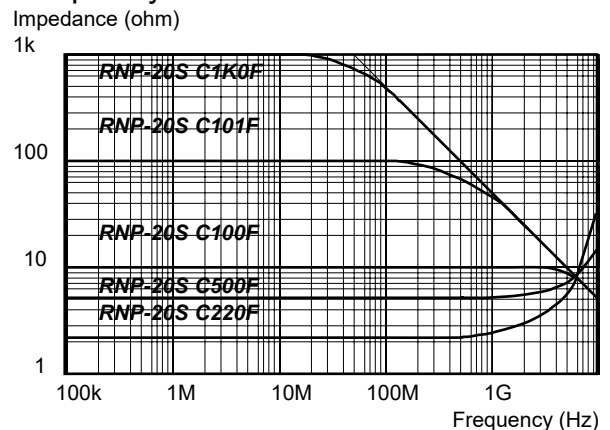

Note:

- Insulating material is unnecessary between flange and heat-sink, flange and resistor is separated by alumina substrate.
- Resistance measurement shall be made at a point 5.27mm +/-0.6 mm from the resistor body.
- TCR of low resistance will be increased as 300ppm/0.02ohm, 200ppm/0.05ohm, 140ppm/0.1ohm and 80ppm/0.2ohm typically. Testing point is at 5.27mm from bottom of molding of terminals.
- Test method is IEC60068-2-6, and specification is sine sweep wave form, 100Hz-2000Hz, 10 cycles, amplitude 0.75mm or 100m/s², 90minutes. direction x-y z, Amplitude 0.75mm will be applied under break point Frequency (about 60Hz) and 100m/ s² over break point
- When mounting resistor on heat-sink by screw, clip and pressure strip with using heat conduction grease on back side of resistor are recommended. Recommended screw torque is 0.5-0.6Nm.
- 0.1% tolerance resistors is available, please see datasheet of RNP-20P.
- Standard packaging is RoHS PS/PE tube packaging, which contains 50pcs / tube.

20161101

TO220 50W HIGH POWER RESISTORS

RNP-50U

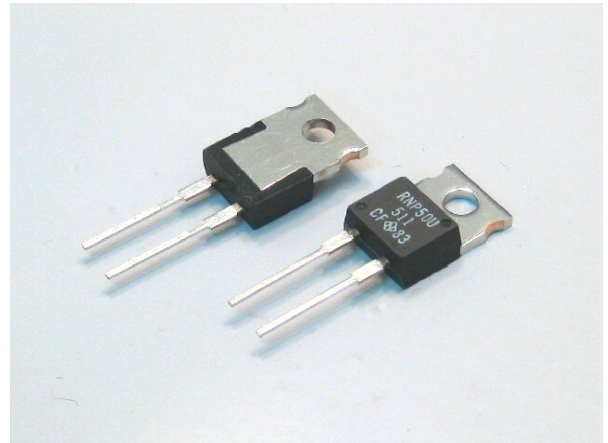

Features and Applications

50W high power resistors in TO220 style mold package for through-hole and screw mounting. AEC-Q200 test certified.
 Non-inductive design suits high frequency applications and high-speed pulse circuits.
 Low, 2.3 °C/W heat resistance from resistor hot spot to flange and long life performance are presented with thin film metallization technology and rejection of plastic adhesive joint.
 Wide 20 milliohm to 510kohm wide resistance range, non-inductive impedance characteristic and heat conduction through the insulated metal flange aids circuit designers.
 Small size and thin profile suit high-density compact installations.
 Complete thermal conduction, heat dissipation design and vibration durable design also available.
 Applications include snubber, gate control, bleeder, filter, rush current protection, braking resistors of automotive, rail traction, wind turbine, PV, UPS and motor control inverters.

Dimensional Specifications (mm)

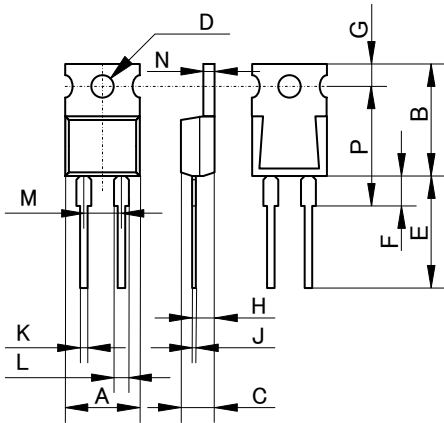

RNP-50U		
	mm	+/-mm
A	10.1	+/-0.2
B	15.0	+/-0.2
C	4.5	+/-0.2
D	3.6	+/-0.1
E	15.5	+/-1.0
F	4.0	+/-0.5
G	3.0	+/-0.2
H	2.75	+/-0.2
J	0.5	+/-0.05
K	0.75	+/-0.05
L	1.5	+/-0.05
M	5.08	+/-0.10
N	1.5	+/-0.05
P	16.0	+/-0.50

Structure and Material

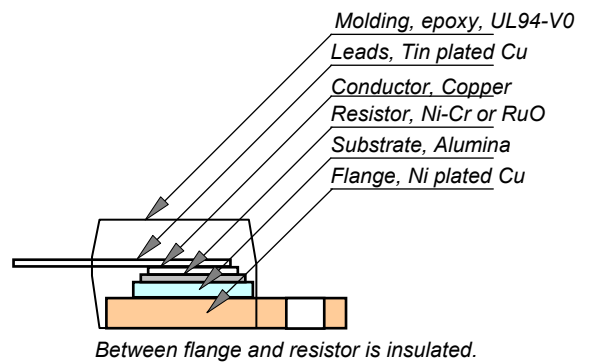

Ordering Information

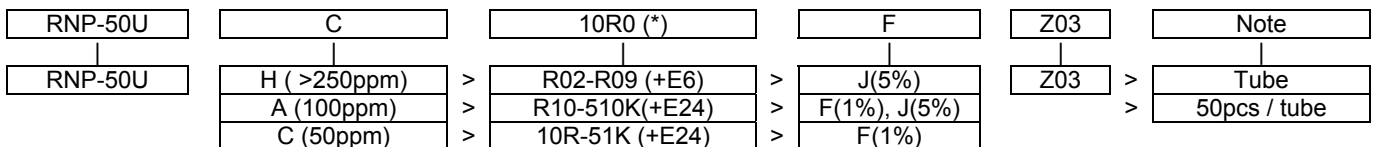

Resistance value (*) is available following modified E24, +E24.

1.0	1.1	1.2	1.3	1.5	1.6	1.8	2.0	2.2	2.4	2.5	2.7	3.0	3.3
3.6	3.9	4.0	4.3	4.7	5.0	5.1	5.6	6.2	6.8	7.5	8.0	8.2	9.1

Note*: When ordering, additional ohm resistance notation recommends for keeping out of misunderstanding.

TO220 50W HIGH POWER RESISTORS

RNP-50U

Specifications

		RNP-50U		Test Conditions
Rated Power	50 Watt			-55 °C to 25 °C flange temperature
Rating Power	1 Watt			Free air.
Heat Resistance	2.3 °C/W			Hot spot to flange
Resistance Range	0.02-0.09ohm	0.1-510 k ohm	10-51Kohm	Note 2
Nominal Resistance	E6	E24+	E24+	Include 2.5, 4.0, 5.0, 8.0 and 16
TCR, ppm/°C	>250 (H)	100 (A)	50 (C)	Note 3
Tolerance	5%(J)	1% (F), 5% (J)	+/-1% (F)	1% tolerance at 0.01-0.091 ohm is available optionally.
Resistor Material	Thick Film		Thin Film	
Capacitance	1.69pF			Equivalent parallel capacitance.
Inductance	9.65nH			Equivalent series inductance
Operation Temp.	-55 °C to +175 °C			
Max. Operating Volt.	smaller either 700V or $\sqrt{P \times R}$			P is rating power and R resistance
Withstanding Voltage	2000VAC			Terminal and flange, 60 seconds, 1mA
Load Life	+/- 1.0 %			25 °C, 90 min. ON, 30 min. OFF, 1000 hours.
Humidity	+/- 1.0 %			40 °C, 90-95%RH, DC 0.1W, 1000 hours.
Temp. Cycle	+/- 0.25 %			-55 °C,30 min.,+155 °C,30 min., 5cycles
Soldering Heat	+/- 0.1 %			350+/-5 °C, 3seconds,
Solder ability	Over 95% of surface			230+/-5 °C, 3seconds.
Insulation Resistance	Over 1,000 Meg ohm			Between terminals and flange.
Vibration	+/- 0.25 %			IEC60068-2-6, see note 4
Weight	2.1 grams			

Derating

Rating Power (W)

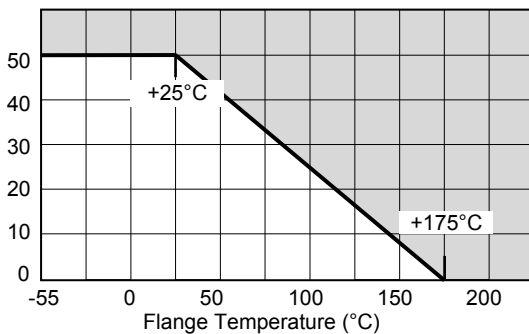

Temperature Rise

Temperature Rise (°C)

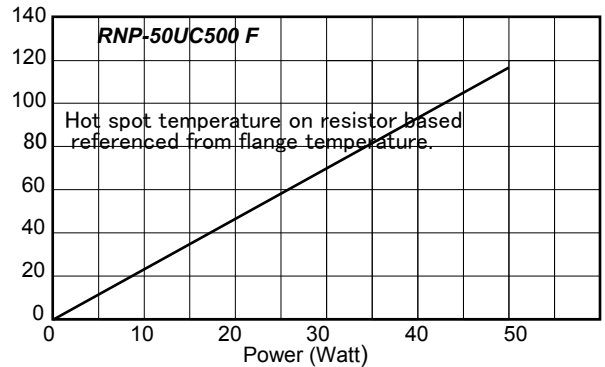

Pulse Energy Durability

Pulse peak power (W)

Applied to RNP-50UC10ohmF and resistance < 100ohm

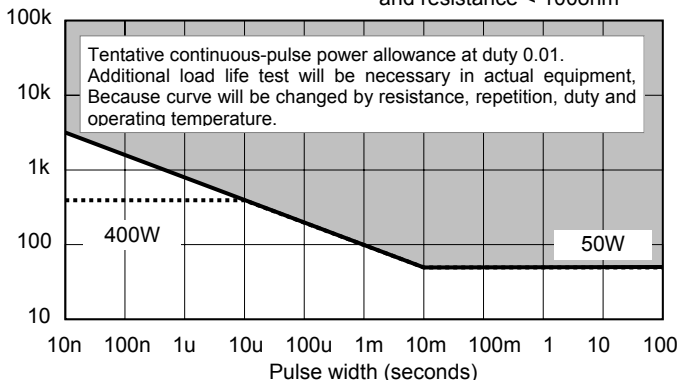

Frequency Characteristics

Impedance (ohm)

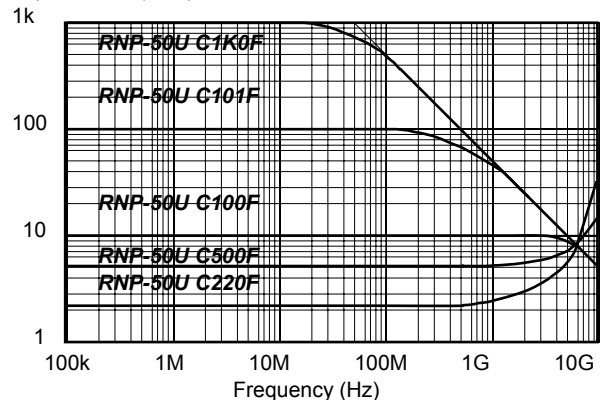

Note:

- Insulation material is unnecessary between flange and heat-sink, flange and resistor is separated by alumina substrate.
- Resistance measurement shall be made at a point 5.27mm +/-0.6 mm from the resistor body.
- TCR of low resistance will be increased as 300ppm/0.02ohm, 200ppm/0.05ohm, 140ppm/0.1ohm and 80ppm/0.2ohm typically. Testing point is at 5.27mm from bottom of molding of terminals.
- Test method is IEC60068-2-6, and specification is sine sweep wave form, 100Hz-2000Hz, 10 cycles, amplitude 0.75mm or 100m/s², 90minutes. direction x-y z, Amplitude 0.75mm will be applied under break point Frequency (about 60Hz) and 100m/s² over break point
- When mounting resistor on heat-sink by screw, clip and pressure strip with using heat conduction grease on back side of resistor are recommended. Recommended screw torque is 0.5-0.6Nm.
- Standard packaging is anti-static PE tray, which contains 100pcs / tray.

20161101

TO247 100W HIGH POWER RESISTORS

RNP-50S

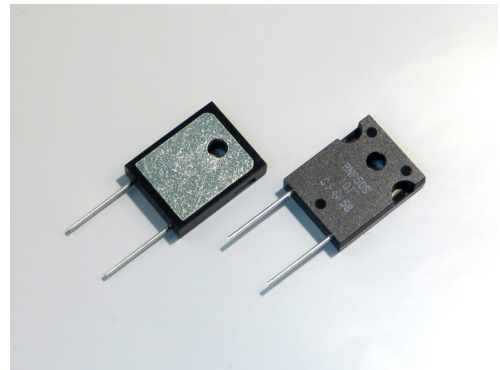

Features and Applications

100W high power resistor in TO247 molded package.
 Non-inductive design suits high frequency applications and high-speed pulse circuits.
 Low, 1.3 °C/W heat resistance from resistor to flange and long life performance are presented with thin film metallization technology and rejection of plastic adhesive joint.
 Wide 20 milliohm to 510kOhm resistance range, non-inductive impedance characteristic and heat conduction through the insulated metal flange aids circuit designers.
 Small size and thin profile suit high-density compact installations.
 Complete thermal conduction, heat dissipation design and vibration durable design also available.
 Applications include snubber, gate control, bleeder, filter, rush current protection, braking resistors of automotive, rail traction, wind turbine, PV, UPS and motor control inverters.

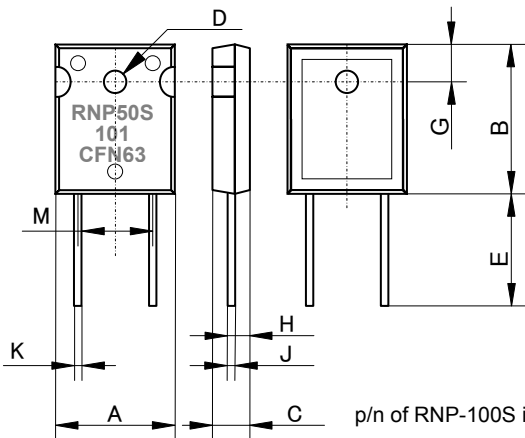

RNP-50S		
	mm	+/-mm
A	16.0	+/-0.2
B	20.0	+/-0.5
C	4.8	+/-0.2
D	3.55*	+/-0.1
E	14.5	+/-0.5
F	-	-
G	5.1	+/-0.5
H	3.63	+/-0.2
J	-	-
K	0.8	+/-0.05
L	-	-
M	10.9	+/-0.1
N		

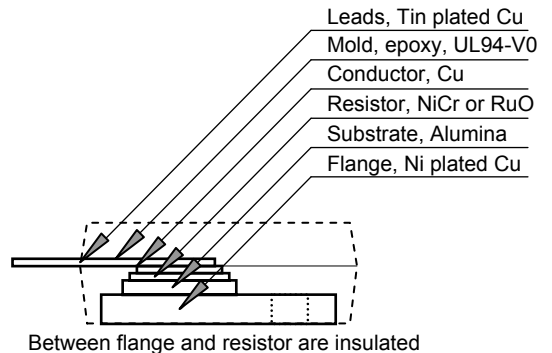

p/n of RNP-100S includes '-', but marking omits '-'.
 Note(*): Dimension D, 3.20 mm was changed to 3.55 mm from April 2009.

Specifications and Performances

Note(*): Dimension D, 3.20 mm was changed to 3.55 mm from April 2009.

	RNP-50S			Test Conditions
Rating Power	100 Watts			-55 °C to +25 °C flange temperature.
Rating Power	3.0 Watts			Free air.
Heat Resistance	1.3 °C/W			Hot spot to flange.
Resistance Range	0.02-0.09 Ohm	0.1-510k Ohm	10-51k Ohm	Note 2
Nominal Resistance	+E6	+E12	+E24	Include 2.5, 4.0, 5.0, 8.0 and 16
TCR (ppm/°C)	>250(H)	100(A)	50(C)	Note 3
Tolerance	+/-5%	+/-5%, +/-1%	+/-1%	1% tolerance at 0.01-0.091 ohm is available optionally.
Resistor Material	Thick Film		Thin Film	
Capacitance	2.35pF			Equivalent parallel capacitance.
Inductance	11.72nH			Equivalent series inductance
Operation Temp. Range	-55 °C to +175 °C			
Max. Applied Voltage	smaller value either 700V or $\sqrt{P \cdot R}$			P is rating power and R resistance
Withstanding Voltage	2500 VAC			Terminal and flange, 60 seconds, 1mA
Load Life	+/- 1.0 %			25 °C, 90 min. ON, 30min.OFF, 1000hours.
Humidity	+/-1.0 %			40 °C, 90 - 95%RH, DC0.1W, 1000hours.
Temperature Cycle	+/- 0.25 %			-55C, 30 min., +175 °C, 30min., 5cycles.
Soldering Heat	+/- 0.25 %			350+/-5 °C, 3 seconds,
Solder ability	Over 95% area of round			235+/-5 °C, 5 seconds.
Insulation Resistance	Over 1000 Meg ohm			Between terminals and flange
Vibration	+/- 0.25 %			IEC60068-2-6, see note 4
Weight	6.4 grams			

TO247 100W HIGH POWER RESISTORS

RNP-50S

Ordering Information

RNP-50S	C	10R0 (*)	F	Z03	Note
RNP-50S	H (>250ppm)	R02-R09 (+E6)	J (5%)	Z03	Tube / 25 pcs
	A(100ppm)	R10-510K (+E24)	F(1%), J(5%)	Z05	Tray / 50pcs
	C(50ppm)	10R-51K (+E24)	F(1%)		

Resistance value (*) is available following modified E24, +E24.

1.0	1.1	1.2	1.3	1.5	1.6	1.8	2.0	2.2	2.4	2.5	2.7	3.0	3.3
3.6	3.9	4.0	4.3	4.7	5.0	5.1	5.6	6.2	6.8	7.5	8.0	8.2	9.1

Note*: When ordering, additional ohm resistance notation is recommended.

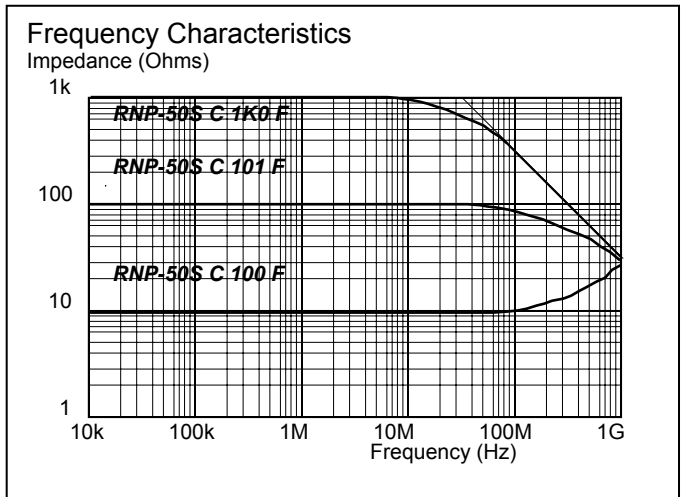
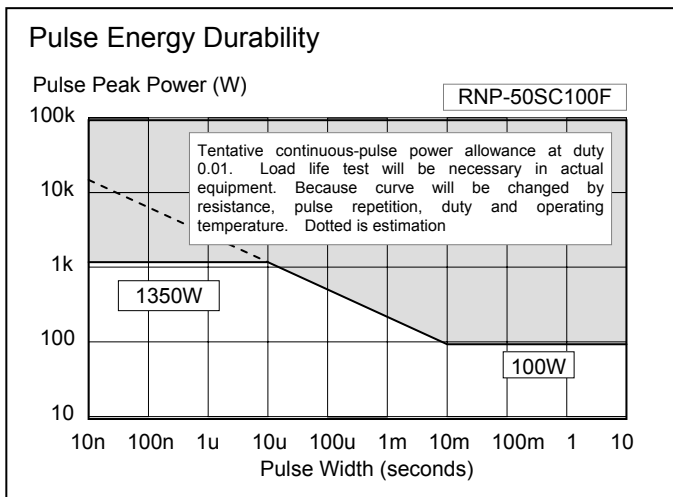
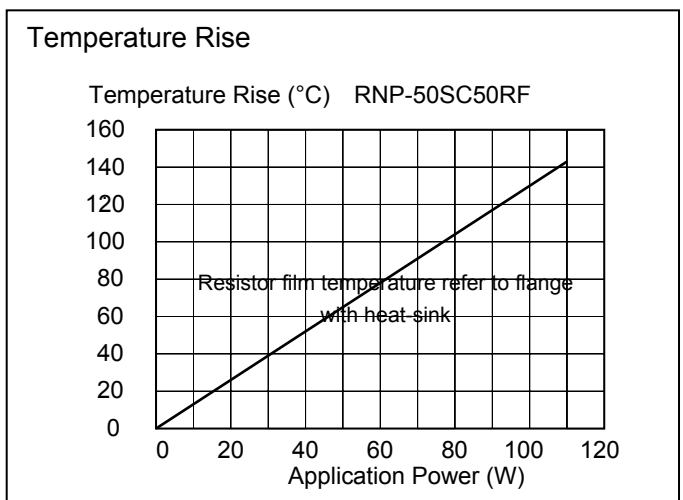
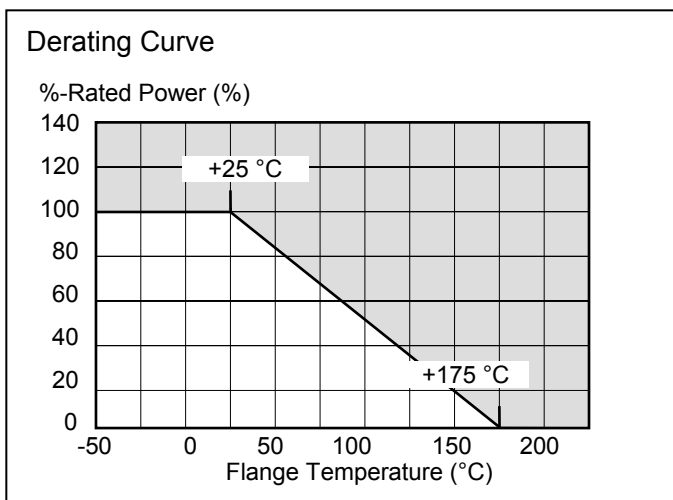

Note:

- (1) Insulation material is unnecessary between flange and heat-sink, flange and resistor is separated by alumina substrate.
- (2) Resistance measurement shall be made at a point 2.54mm±1.0mm from the resistor body.
- (3) TCR of low resistance will be increased as 300ppm/0.02ohm, 200ppm/0.05ohm, 140ppm/0.1ohm and 80ppm/0.2ohm typically. Testing point is at 2.54mm from bottom of molding of terminals.
- (4) Test method is IEC60068-2-6, and specification is sine sweep wave form, 100Hz-2000Hz, 10 cycles, amplitude 0.75mm or 100m/s², 90minutes. direction x-y z, Amplitude 0.75mm will be applied under break point Frequency (about 60Hz) and 100m/s² over break point
- (5) When mounting resistor on heat-sink by screw, clip and pressure strip with using heat conduction grease on back side of resistor are recommended. Recommended screw torque is 0.5-0.6Nm. In case of screw mount, ISO M3 screw is necessary, 1/8" screw cannot be acceptable.
- (6) Standard packaging is anti-static PE tube, which contains 25pcs / tube.

20161101

TO247 140W HIGH POWER RESISTORS

RNP-100S

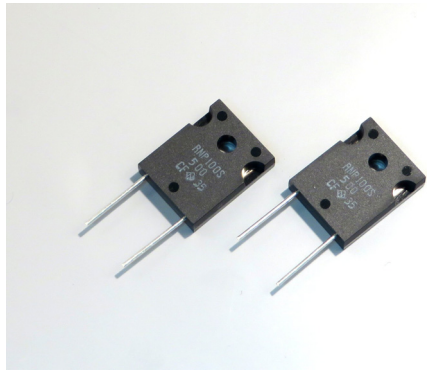

Features and Applications

140W high power resistor in TO247 molded package.
 Non-inductive design suits high frequency applications and high-speed pulse circuits.
 Low, 0.9 deg C/W heat resistance from resistor hot spot to flange and long life performance are presented with thin film metallization technology and rejection of plastic adhesive joint.
 Wide 100 milliohm to 51kOhm resistance range, non-inductive impedance characteristic and heat conduction through the insulated metal flange aids circuit designers.
 Small size and thin profile suit high-density compact installations.
 Complete thermal conduction, heat dissipation design and vibration durable design also available.
 Applications include snubber, gate control, bleeder, filter, rush current protection, braking resistors of automotive, rail traction, wind turbine, PV, UPS and motor control inverters..

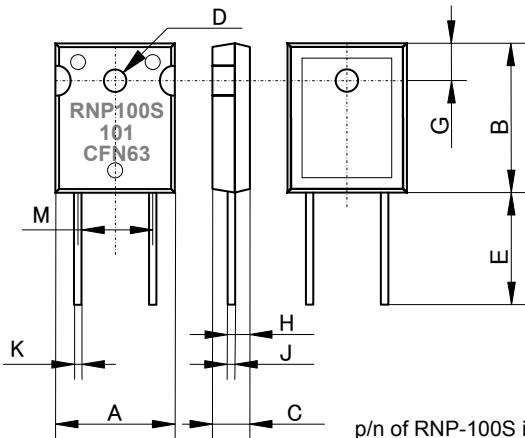

RNP-100S		
	mm	+/-mm
A	16.0	+/-0.2
B	20.0	+/-0.5
C	4.8	+/-0.2
D	3.55*	+/-0.1
E	14.5	+/-0.5
F	-	-
G	5.1	+/-0.5
H	3.63	+/-0.2
J	-	-
K	0.8	+/-0.05
L	-	-
M	10.9	+/-0.1
N		

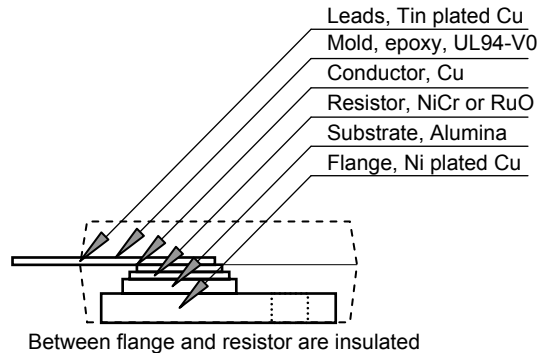

p/n of RNP-100S includes '-', but marking omits '-'.
 *p/n of RNP-100S includes '-', but marking omits '-'.

Specifications and Performances

	RNP-100S			Test Conditions
Rating Power	140 Watts			-55 °C to +25 °C flange temperature.
Rating Power	3.0 Watts			Free air.
Heat Resistance	0.9 °C/W			Hot spot to flange
Resistance Range	0.02-0.09 Ohm	0.1-510k Ohm	10-51k Ohm	Note 2
Nominal Resistance	+E6	+E12	+E24	Include 2.5, 4.0, 5.0, 8.0 and 16
TCR (ppm/°C)	>250(H)	100(A)	50(C)	Note 3
Tolerance	+/-5%	+/-5%, +/-1%	+/-1%	1% tolerance at 0.01-0.091 ohm is available optionally.
Resistor Material	Thick Film		Thin Film	
Capacitance	3.68pF			Equivalent parallel capacitance.
Inductance	12.25nH			Equivalent series inductance
Operation Temp. Range	-55 °C to +175 °C			
Max. Applied Voltage	smaller value either 700V or $\sqrt{P \cdot R}$			P is rating power and R resistance
Withstanding Voltage	2500 VAC			Terminal and flange, 60 seconds, 1mA
Load Life	+/- 1.0 %			25 °C, 90 min. ON, 30min.OFF, 1000hours.
Humidity	+/-1.0 %			40 °C, 90 - 95%RH, DC0.1W, 1000hours.
Temperature Cycle	+/- 0.25 %			-55 °C, 30 min., +175 °C, 30min., 5cycles.
Soldering Heat	+/- 0.25 %			350+/-5 °C, 5 seconds,
Solder ability	Over 95% surface area of leads			235+/-5 °C, 5 seconds.
Insulation Resistance	Over 1000 Meg ohm			Between terminals and flange
Vibration	+/- 0.25 %			IEC60068-2-6, see note 4
Weight	6.3 grams			

TO247 140W HIGH POWER RESISTORS

RNP-100S

Ordering Information

Model	TCR	Resistance	Tolerance	Code	Note
RNP-100S	C	101	F	Z03	
RNP-100S	H (>=250ppm)	R02-R09 (+E6)	J(5%)	Z03	Tube / 25pcs
	A (100ppm)	R10-510K (+E24)	F(1%), J(5%)	Z05	Tray / 50pcs
	C (50ppm)	10R-51K (+E24)	F(1%)		

Resistance value (*) is available following modified E24, +E24.

1.0	1.1	1.2	1.3	1.5	1.6	1.8	2.0	2.2	2.4	2.5	2.7	3.0	3.3
3.6	3.9	4.0	4.3	4.7	5.0	5.1	5.6	6.2	6.8	7.5	8.0	8.2	9.1

Note*: When ordering, additional ohm resistance notation is recommended for keeping out of misunderstanding.

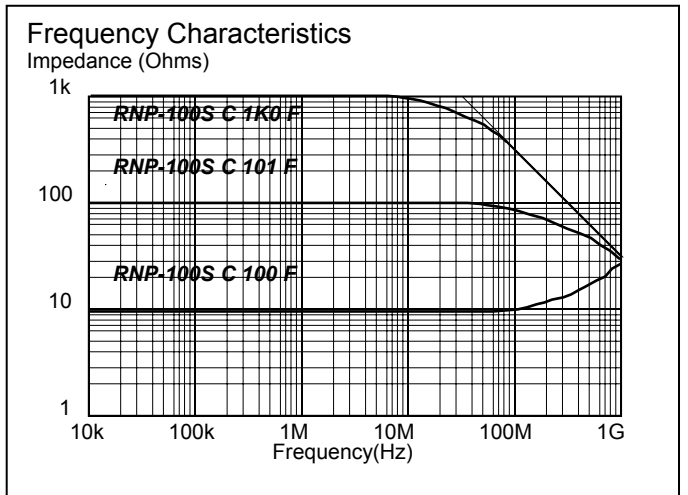
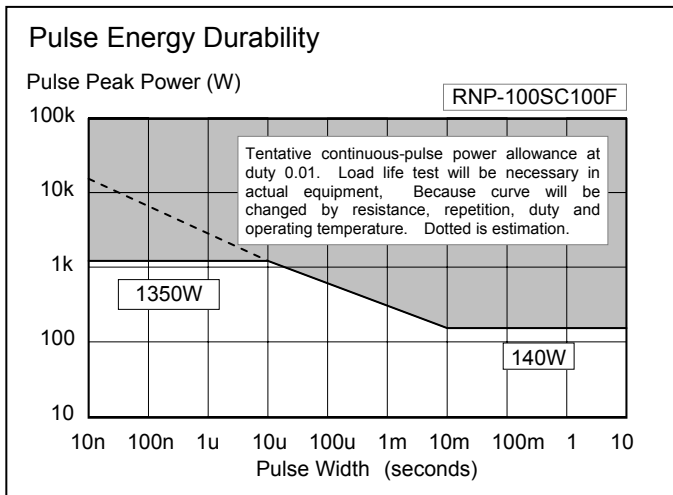
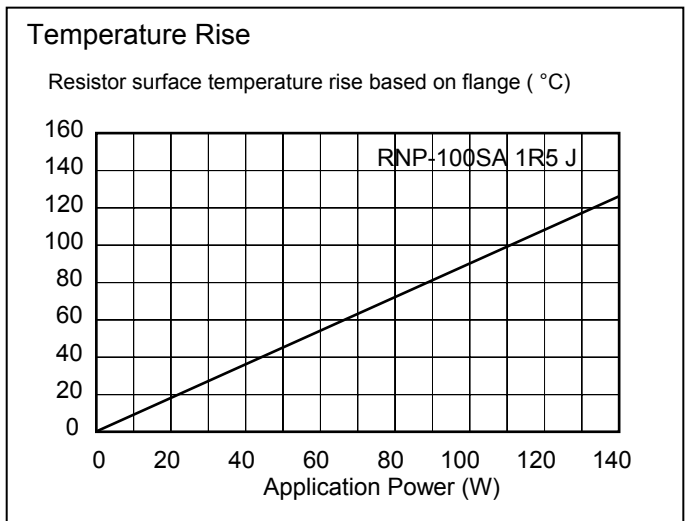
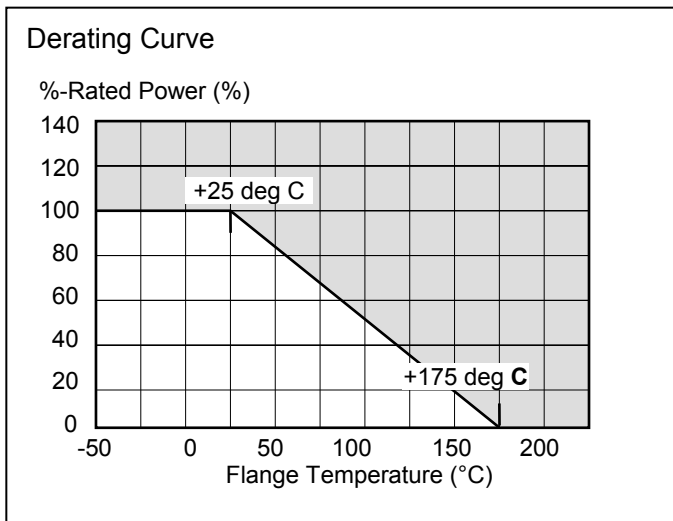

Note:

- (1) Insulation material is unnecessary between flange and heat-sink, flange and resistor is separated by alumina substrate.
- (2) Resistance measurement shall be made at a point 2.54mm+/-1.0mm from the resistor body.
- (3) TCR of low resistance will be increased as 300ppm/0.02ohm, 200ppm/0.05ohm, 140ppm/0.1ohm and 80ppm/0.2ohm typically. Testing point is at 2.54mm from bottom of molding of terminals.
- (4) Test method is IEC60068-2-6, and specification is sine sweep wave form, 100Hz-2000Hz, 10 cycles, amplitude 0.75mm or 100m/s², 90minutes. Direction x-y-z, Amplitude 0.75mm will be applied under break point Frequency (about 60Hz) and 100m/ s² over break point
- (5) When mounting resistor on heat-sink by screw, clip and pressure strip with using heat conduction grease on back side of resistor are recommended. Recommended screw torque is 0.5-0.6Nm. In case of screw mount, ISO M3 screw is necessary, also, 1/8" screw can be acceptable.
- (6) Standard packaging is anti-static PE tube, which contains 25 pcs / tube.

TO247 100W HIGH POWER RESISTORS

RNP-100U

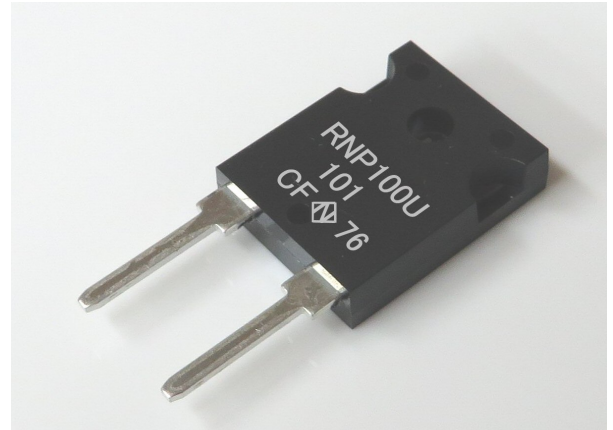

Features and Applications

100W high power resistor in TO-247 molded package.

Only 1.3 °C/W heat resistance between resistor and flange for excellent cooling.

Non-inductive designs fit for high frequency circuit and wide band amplifiers.

Small size and thin shape fit for high density design of power electronics.

Complete thermal conduction and heat dissipation design will be available.

Applications include power electronics / inverter of automotive, rail traction, wind turbine, PV, UPS and industrial motor control as harmonic filter, dumping, snubber, gate control, bleeder resistor and rush current protection,

Dimensions

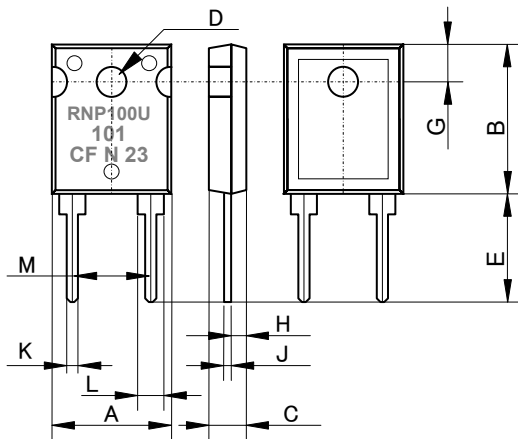

	mm	+/-mm	inches	+/-inch
A	16.0	+/-0.2	0.630	+/-0.008
B	20.0	+/-0.5	0.787	+/-0.020
C	4.8	+/-0.2	0.189	+/-0.008
D	3.55	+/-0.1	0.140	+/-0.004
E	14.5	+/-0.5	0.571	+/-0.020
F	-	-		
G	5.1	+/-0.5	0.200	+/-0.020
H	3.63	+/-0.2	0.143	+/-0.008
J	0.80	+/-0.1	0.060	+/-0.004
K	1.52	+/-0.1	0.060	+/-0.004
L	3.63	+/-0.18	0.143	+/-0.007
M	10.16	+/-0.26	0.400	+/-0.010

Specifications and Performances

Specification Items	Specification-Performance			Test Conditions
Rating Power	100 Watts			Note, at 25 °C flange temperature
Rating Power	3.0 Watts			Free air.
Heat Resistance	1.3 °C/W			From resistor to flange
Resistance Range	0.02-0.09Ω	0.1-1M Ω	10-51K Ω	
Nominal Resistance	+E12	+E24	+E24	+ shows Additional 2.0 and 5.0.
TCR	250ppm/°C	100 ppm/°C	50 ppm/°C	For -55 to +175 °C
Tolerance	+/-5%	+/-1%, 5%	+/-1%	
Capacitance	2.35 pF			At point of terminal length 10mm
Inductance	11.72 nH			At point of terminal length 10mm
Operation Temp. Range	-55 - +155 °C			
Max. Applied Voltage	500V or $\sqrt{P \cdot R}$			Max operating current 20A
Max. Operating Current	40A			
Short Time Overload	+/-0.5%			1.5 times rated power for 5 seconds
Withstanding Voltage	2500VAC			60 seconds. 1mA
Load Life	+/-1.0 %			25°C, 90 min.ON, 30min.OFF, 1000hours.
Humidity	+/-1.0 %			70°C, 90 - 95%RH, DC0.1W, 1000hours.
Temperature Cycle	+/-0.25 %			-55°C, 30 min., +155°C 30min., 5cycles.
Soldering Heat	+/-0.25 %			350+/-5 °C, 3seconds,
Solder ability	Over 3/4 of round			230+/-5 °C, 3seconds.
Insulation Resistance	Over 1000 Meg Ω			Between terminals and tab.
Vibration	+/-0.25 %			
Flammability	UL94V-0			
Weight	7.2 grams			

TO247 100W HIGH POWER RESISTORS

RNP-100U

形名呼称 Ordering Information

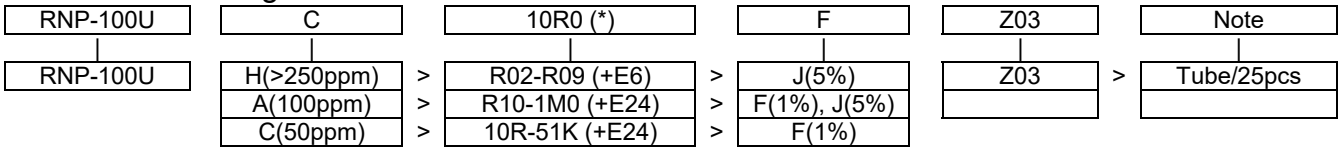

Resistance value (*) is available following modified E24, +E24.

1.0	1.1	1.2	1.3	1.5	1.6	1.8	2.0	2.2	2.4	2.5	2.7	3.0	3.3
3.6	3.9	4.0	4.3	4.7	5.0	5.1	5.6	6.2	6.8	7.5	8.0	8.2	9.1

Note*: When ordering, additional ohm resistance notation is recommended for keeping out of misunderstanding.

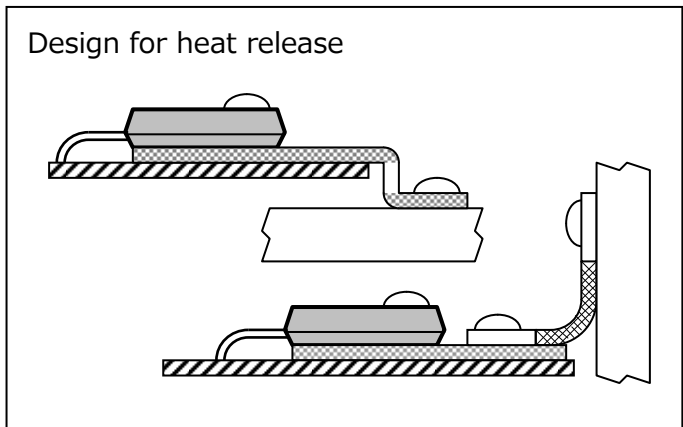
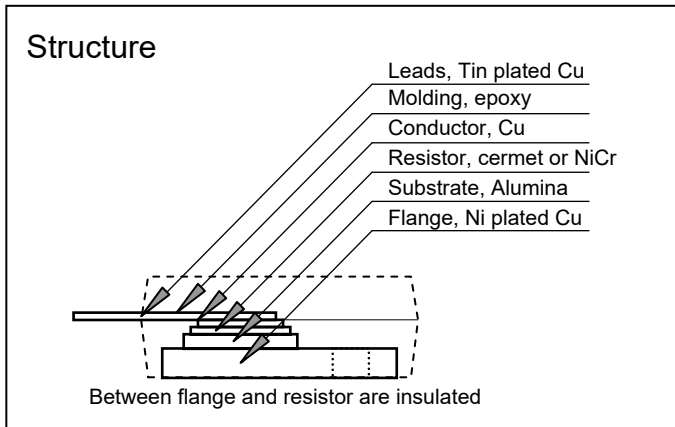
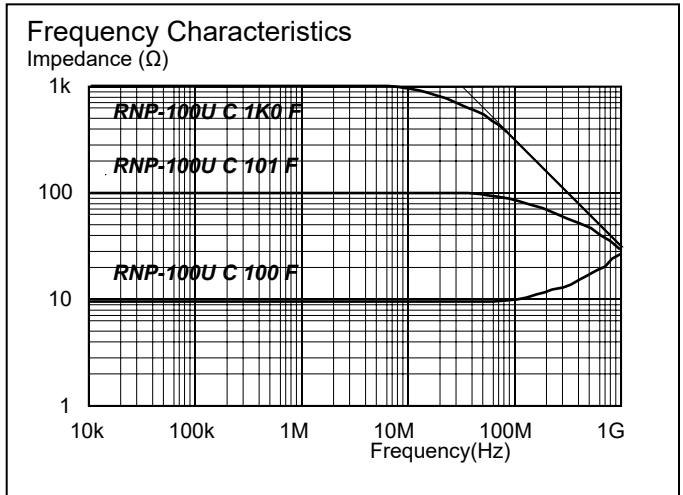
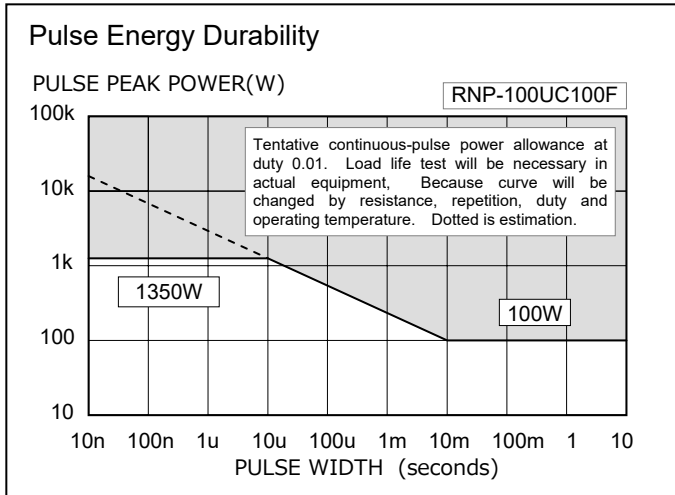
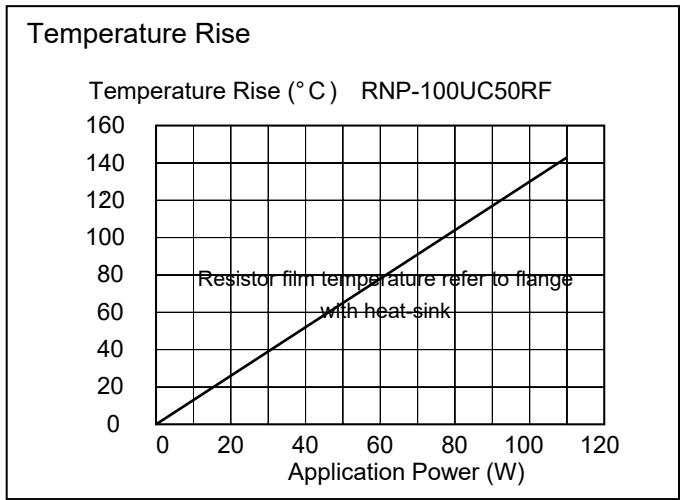
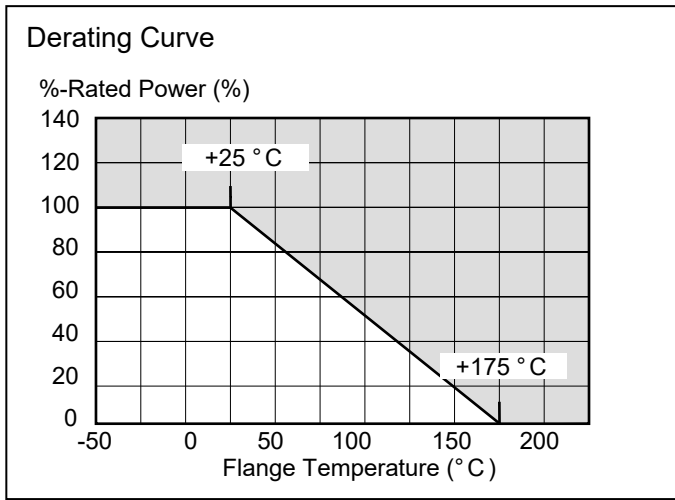

TO247 140W HIGH POWER RESISTORS

RNP-140U

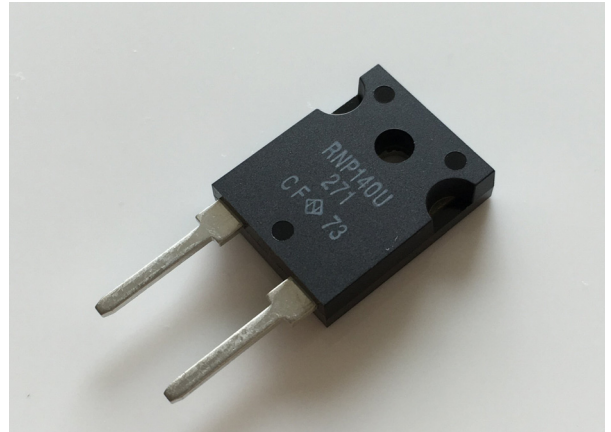

Features and Applications

140W high power resistor in TO-247 molded package.

Only 0.9 °C/W heat resistance between resistor and flange for excellent cooling.

Wide 10mΩ to 510kΩ resistance range, non-inductive design fit for high frequency circuit and wide band amplifiers.

Small size and thin shape provides for high density design of power electronics.

Complete thermal conduction and heat dissipation design will be available.

Applications include power electronics / inverter of automotive, rail traction, wind turbine, PV, UPS and industrial motor control as harmonic filter, dumping, snubber, gate control, bleeder resistor and rush current protection,

Dimensions

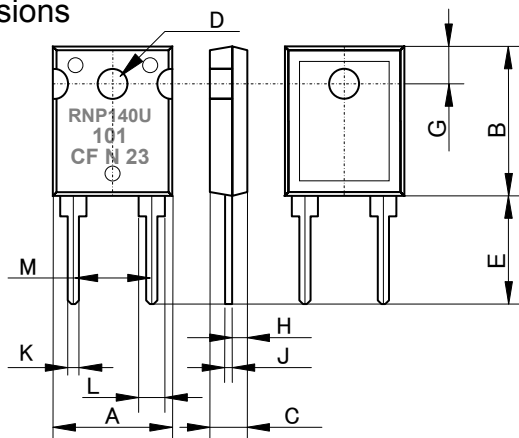

	mm	+/-mm	inches	+/-inch
A	16.0	+/-0.2	0.630	+/-0.008
B	20.0	+/-0.5	0.787	+/-0.020
C	4.8	+/-0.2	0.189	+/-0.008
D	3.55	+/-0.1	0.140	+/-0.004
E	14.5	+/-0.5	0.571	+/-0.020
F	-	-		
G	5.1	+/-0.5	0.200	+/-0.020
H	3.63	+/-0.2	0.143	+/-0.008
J	0.80	+/-0.1	0.060	+/-0.004
K	1.52	+/-0.1	0.060	+/-0.004
L	3.63	+/-0.18	0.143	+/-0.007
M	10.16	+/-0.26	0.400	+/-0.010

Specifications and Performances

Specification Items	Specification-Performance			Test Conditions
Rating Power	140 Watts			Note, at 25 °C flange temperature
Rating Power	3.0 Watts			Free air.
Heat Resistance	0.9 °C/W			From resistor to flange
Resistance Range	0.01 - 0.099Ω	0.1 - 510K Ω	10-51K Ω	
Nominal Resistance	+E12	+E24	+E24	+ shows Additional 2.0 and 5.0.
TCR	> 250ppm/°C	100 ppm/°C	50 ppm/°C	For -55 to +175 °C
Tolerance	+/-5%	+/-1%, 5%	+/-1%	
Capacitance	3.68 pF			At point of terminal length 10mm
Inductance	12.25 nH			At point of terminal length 10mm
Operation Temp. Range	-55 - +175 °C			
Max. Applied Voltage	500V or $\sqrt{P \cdot R}$			
Max. Operating Current	40A			
Short Time Overload	+/-0.5%			1.5 times rated power for 5 seconds
Withstanding Voltage	2500VAC			60 seconds, 1mA
Load Life	+/-1.0 %			25°C, 90 min.ON, 30min.OFF, 1000hours.
Humidity	+/-1.0 %			70°C, 90 - 95%RH, DC0.1W, 1000hours.
Temperature Cycle	+/-0.25 %			-55°C, 30 min., +155°C 30min., 5cycles.
Soldering Heat	+/-0.25 %			350+/-5 °C, 3seconds,
Solder ability	Over 3/4 of round			230+/-5 °C, 3seconds.
Insulation Resistance	Over 1000 Meg Ω			Between terminals and tab.
Vibration	+/-0.25 %			
Flammability	UL94V-0			
Weight	7.2 grams			

TO247 140W HIGH POWER RESISTORS

RNP-140U

形名呼称 Ordering Information

RNP-140U	C	10R0 (*)	F	Z03	Note
RNP-140U	H(>250ppm) A(100ppm) C(50ppm)	R01-R099 (+E12) R10-1M0 (+E24) 10R-51K (+E24)	J(5%) F(1%), J(5%) F(1%)	Z03	Tube/25pcs

Resistance value (*) is available following modified E24, +E24.

1.0	1.1	1.2	1.3	1.5	1.6	1.8	2.0	2.2	2.4	2.5	2.7	3.0	3.3
3.6	3.9	4.0	4.3	4.7	5.0	5.1	5.6	6.2	6.8	7.5	8.0	8.2	9.1

Note*: When ordering, additional ohm resistance notation is recommended for keeping out of misunderstanding.

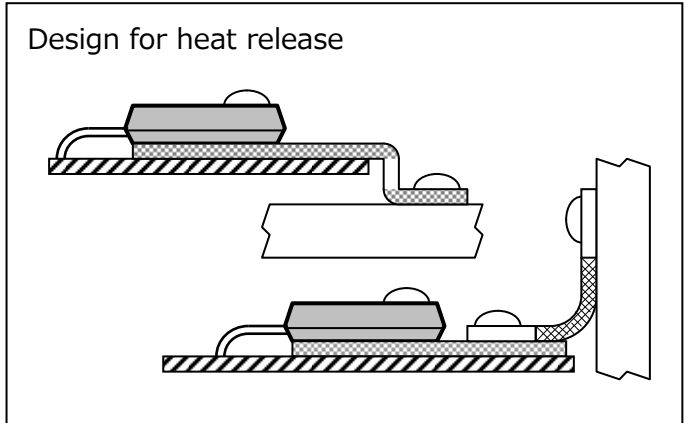
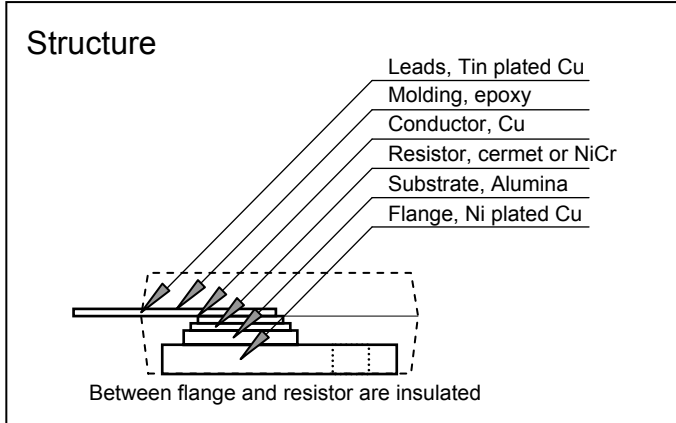
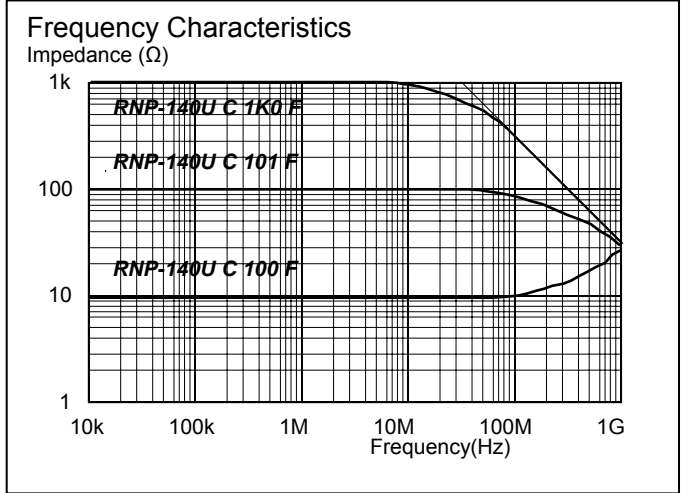
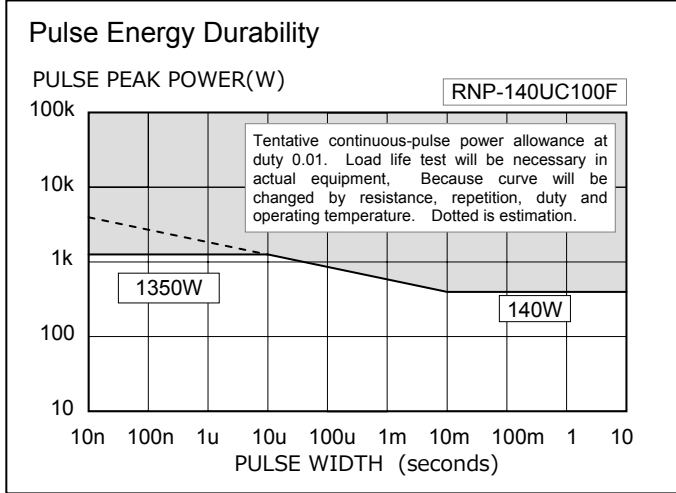
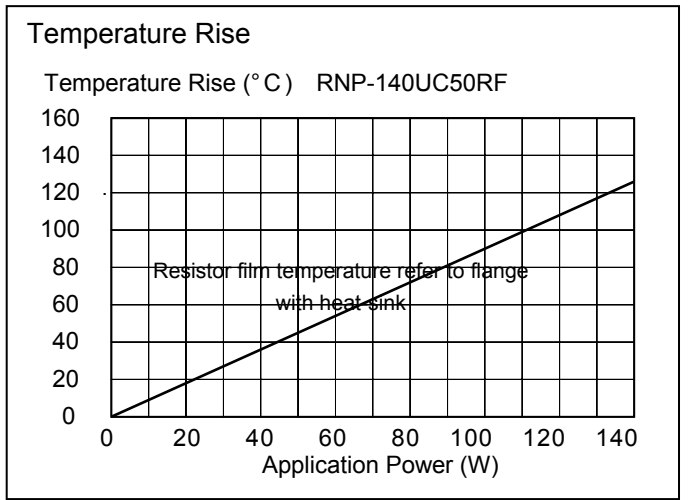
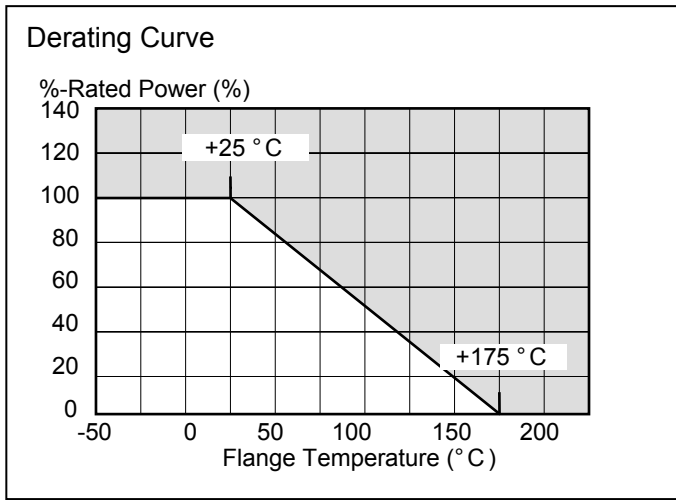

200W, 300W, 600W

CHASSIS MOUNTING NON-INDUCTIVE
HIGH POWER RESISTORS
RPM150, RPM200, RPM250,
RPM300, RPM550, RPM600



Features and Applications

Small size SOT227, 200W to 600W high power resistor. Install on air-cooled heat sink or water-cooling will be necessary.
200W has light weight, 300W is powered by copper metal flange and 600W contains well heat conduction ceramics, ALN substrate. RPM series has 6 types of circuit configuration for each customer's applications.
M4 screw terminals, very low series inductance make small sized high performance power electronics.
Higher density packing, vibration-proof and perfect heat dissipation possible.
Applications include snubber resistors for power supplies, gate resistors, pulse generators, high frequency amplifiers, dumping resistance of theater audio equipment.

Dimensions

	mm	+/- mm
A	38.0	+/-0.2
B	25.0	+/-0.2
C	11.8	+/-0.5
D	4.2	+/-0.1
E	13.0	+/-0.3
F	15.0	+/-0.4
G	30.0	+/-0.1
H	10.0	+/-0.2
J	M4	

Case
Filling
Resistor
Terminals
Conductor
ALO, ALN
Cu flange
Cu flange was eliminated in RPM150 and RPM200.

Note: The depth of the screw hole is about 4.3mm from the surface of the terminal plate.

Schematics

RPM200X, RPM200Y, RPM200Z, RPM300X, RPM300Y, RPM300Z, RPM600X, RPM600Y, RPM600Z
RPM150X, RPM150Y, RPM150Z, RPM250X, RPM250Y, RPM250Z, RPM550X, RPM550Y, RPM550Z

RPM150, RPM200, RPM250, RPM300, RPM550, RPM600
CHASSIS MOUNTING NON-INDUCTIVE HIGH POWER RESISTORS

Ordering Information

Type	Terminal Connection	Terminal Screws Option	Resistance	Tolerance	RoHS
RPM600	Z	S	101 (*)	J	Z00
RPM150	X	-(w/o screws)	+E12	J (5%)	Z00
RPM200	Y	S(w/ screws)	R1=R2=R3		(RoHS)
RPM250	Z	M4-5mm only			
RPM300		(**)			
RPM550					
RPM600					

(*) When a network circuit configuration contains two resistors, ordering is RPM150X101JZ00.

(**) Please see screws option in ordering information M4-5mm only.

電気の仕様 Specifications and Performances

	RPM150	RPM250	RPM200	RPM300	Conditions
Rating Power	150 W	250W	200W	300 W	At flange temp. -55 to +25 deg C
Configuration	XYZ	XYZ	XYZ	XYZ	
Weight	20.0gr	30.0gr	20.0gr	30.0gr	
Thermal Resist.	0.5K/W	0.32 K/W	0.5 K/W	0.32 K/W	
Single or Dual	More than one		One resistor		Same resistance, R1= R2= R3
Resistance Range	0.1Ω to 100KΩ		0.1Ω to 100KΩ		only single Z connection at 0.1-1.0Ω
Resistance	E12+		E12+		Additionally, 2.5 and 5.0.
TCR	+/-100 ppm/K(A)		+/-100 ppm/K(A)		For -55 to +120 C, typical, over1 ohm
Tolerance	+/-5%(J)		+/-5%(J)		1% optional
Operation Temp.	-55 - +155 deg C		-55 - +155 deg C		At resistor element surface
Max. Voltage	$E = \sqrt{P \cdot R}$				
Withstanding	2500 VAC				60 seconds.
Load Life	+/-1.0 %				25C, 90 min.ON, 30min.OFF, 1000h.
Humidity	+/-1.0 %				40C, 90 to 95%RH, DC0.1W, 1000h.
Tem. Cycle	+/-1.0 %				Note 1
Short Time OL	---				Note 2
Insulation	Over 1000 Meg Ω				Between terminals and flange.
Vibration	+/-0.25 %				Note 4
Flammability	UL94V-0				

	RPM550	RPM600	Conditions
Rating Power	600 Watts	600 Watts	At flange temp. -55 to +25 deg C
Configuration	XYZ	XYZ	
Weight	30.0gr	30.0gr	
Thermal Resist.	0.11 K/W	0.11 K/W	
Single or Dual	More than one	One resistor	Same resistance, R1= R2= R3
Resistance Range	50Ω to 500Ω	50Ω to 1KΩ	
Resistance	E12+	E12+	Additionally, 2.5 and 5.0.
TCR	+/-100 ppm/K(A)	+/-100 ppm/K(A)	For -55 to +120 C, typical, over 1 ohm
Tolerance	+/-5%(J)	+/-5%(J)	1% optional
Operation Temp.	-55 - +155 C	-55 - +155 C	At resistor surface
Max. Voltage	$E = \sqrt{P \cdot R}$		
Withstanding	2500 VAC		60 seconds.
Load Life	+/-1.0 %		25C, 90 min.ON, 30min.OFF, 1000h.
Humidity	+/-1.0 %		40C, 90 to 95%RH, DC0.1W, 1000h.
Temp Cycle	+/-1.0 %		Note 1
Short Time OL	---		Note 2
Insulation	Over 1000 Meg Ω		Between terminals and flange.
Vibration	+/-0.25 %		Note 4
Flammability	UL94V-0		

Note1: -55C, 30 min., +120 deg C 30min., 20cycles.

Note2: Several seconds overload can not be applied.

Note3: Torque: Terminal 1.0Nm max, 0.6Nm recommend. Mounting 1.6Nm max, 1.0Nm recommend.

Note 4: IEC60068-2-6, displacement 0.75mm or acceleration 100m/sec^2, 10Hz-54Hz sweep, 10 cycles X-Y-Z direction.

RPM150, RPM200, RPM250, RPM300, RPM550, RPM600
CHASSIS MOUNTING NON-INDUCTIVE HIGH POWER RESISTORS

Performances

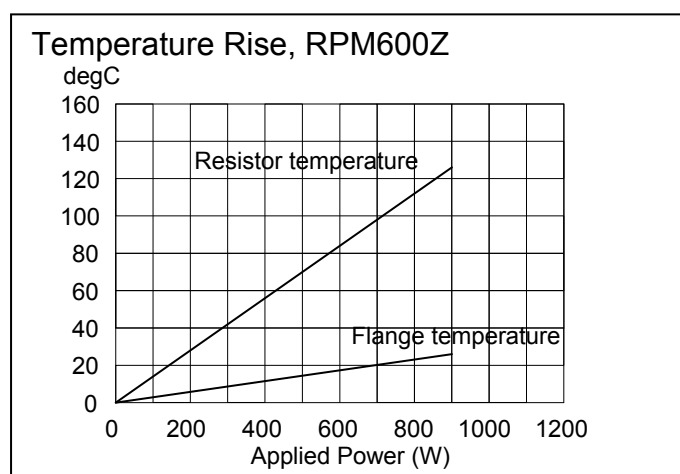
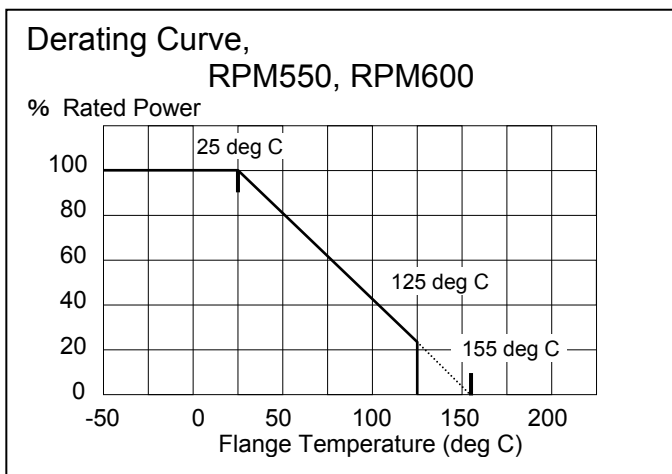
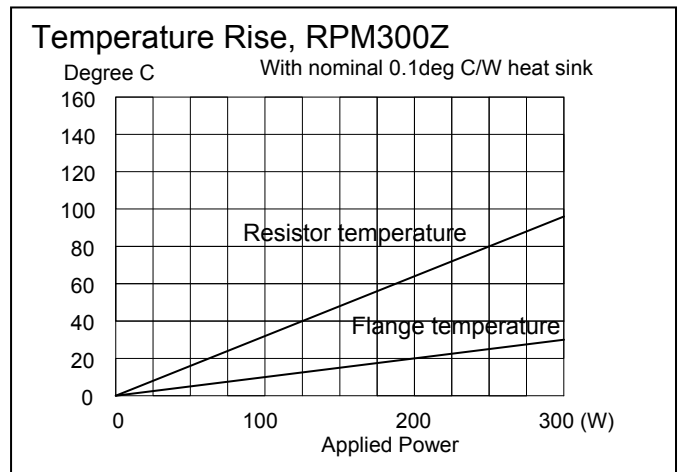
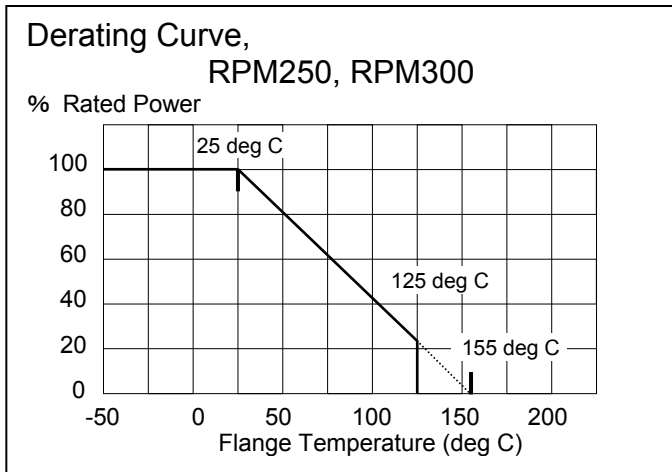
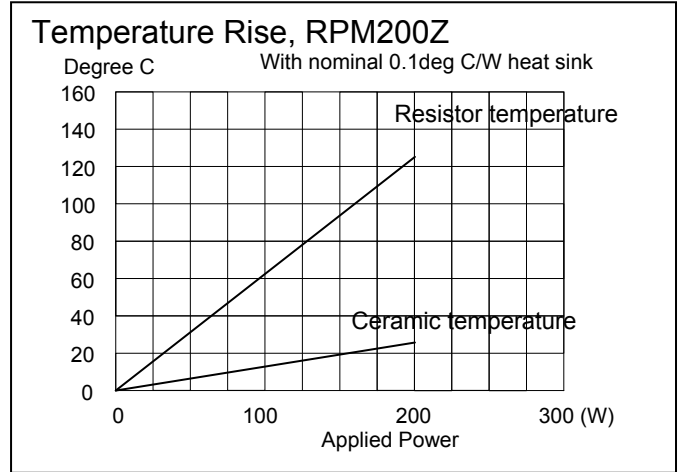
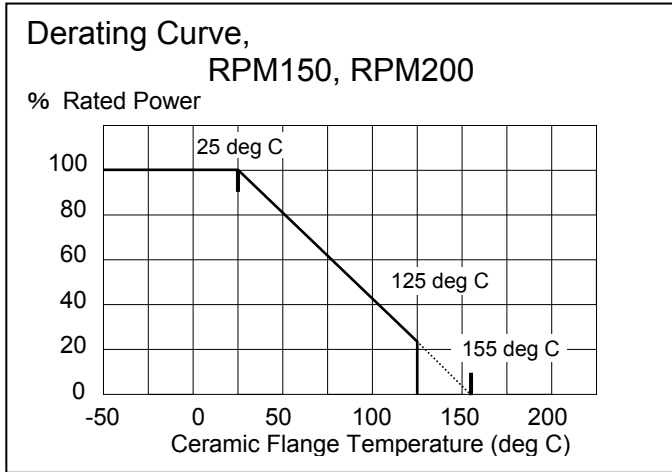

300W
CHASSIS MOUNTING NON-INDUCTIVE
FLAT TYPE HIGH POWER RESISTORS

RPL320

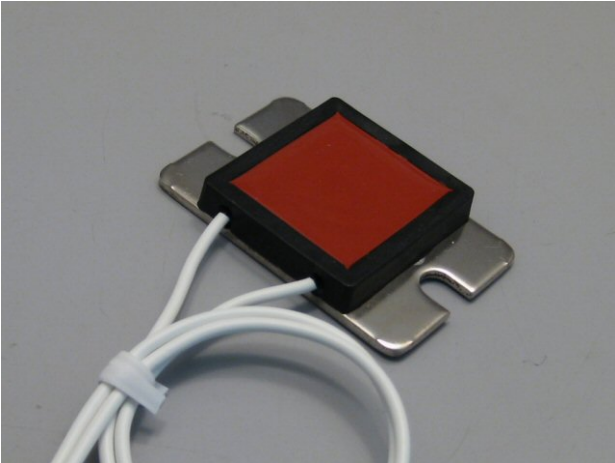

Features and Applications

Flat type, 300W high power resistor. Attaching an air-cooled heat sink or water-cooling necessary.

Rated power is 300W (one element).

Custom resistance and power resistor network available.

Higher density packing, vibration-proof, insulation withstand voltage and perfect heat dissipation possible.

Applications include snubber resistors, surge protection, breeder resistor, filter resistor, dummy load, gate resistor, dumping resistor for power electronics, automotive electronics, pulse generators, high frequency amplifiers, theater audio equipment, etc.

Note: RPL310 was alternated by RPL320.

Dimensions

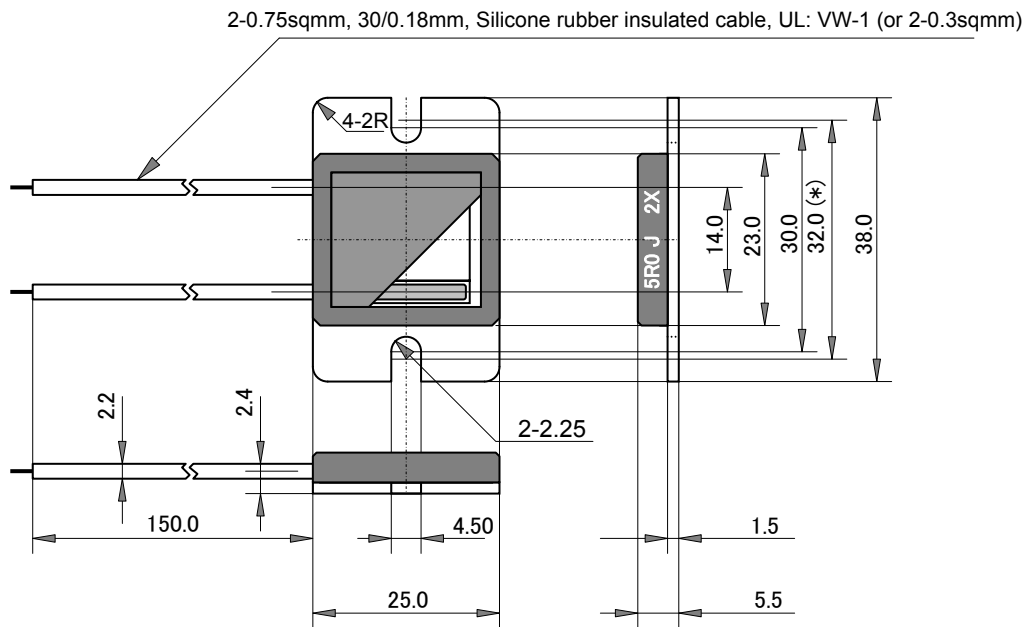

Figure 1. Dimension and Marking (mm)

* M4 for mounting screw.

300W

RPL320

CHASSIS MOUNTING NON-INDUCTIVE FLAT TYPE HIGH POWER RESISTORS

Ordering Information

Type RPL320	TCR A	Resistance 10R	Tolerance J	Code Z05	Note Please note optional '5kVAC'
RPL320 RPL320-5KV	100ppm	10R E24+ (*)	J (5%)	Z05	RoHS (Z), (05) tray package

(*) Recommend resistance value, when request for optional resistance please call factory.

1.0	1.1	1.2	1.3	1.5	1.6	1.8	2.0	2.2	2.4	2.5	2.7	3.0	3.3
3.6	3.9	4.0	4.3	4.7	5.0	5.1	5.6	6.2	6.8	7.5	8.0	8.2	9.1

Specifications and Performances

Items	Specifications	Conditions
Rating Power	300 Watts	At flange temperature -55 to +25 deg C
Heat Resistance	0.23 deg C/W	From resistor to flange
Resistance Range	0.1 ohm to 51K ohm	0.1ohm to 0.82 ohm, option
Nominal Resistance	E24+	Additionally, 2.0 and 5.0.
TCR	+/-100 ppm/K (A)	For -55 to +155 deg C, exclude wire leads
Tolerance	+/-5% (J)	
Operation Temp.	-55 to +155 deg C	At resistor element surface
Limiting Voltage	2000V / $\sqrt{P \times R}$	Less than either 2000V or $\sqrt{P \times R}$, between terminals
Withstanding Voltage	2k VAC (5kVAC option)	60 seconds between terminals and flange. Leak current below 0.5mA
Load Life	ΔR +/-1.0 %	Continuous power 1000 hours.
Humidity	ΔR +/-1.0 %	60 deg C, 90 to 95%RH, DC0.1W, 1000hours.
Temperature Cycle	ΔR +/-1.0 %	-55 deg C, 30 min., +155 deg C 30min., 5 cycles. (-40-+125, 1200cycles)
Insulation Resistance	Over 1000 Meg ohm	Between terminals and flange.
Vibration	ΔR +/-0.5 %	Note 2
Flammability	UL94V-0	For resistor body
Weight	20 grams	May be changed by lead length.

Note 1: Torque: Mounting 1.6Nm max, 1.0Nm recommend.

Note 2: IEC60068-2-6, displacement 0.75mm or acceleration 100m/sec², 10Hz-54Hz sweep, 10 cycles X-Y-Z direction.

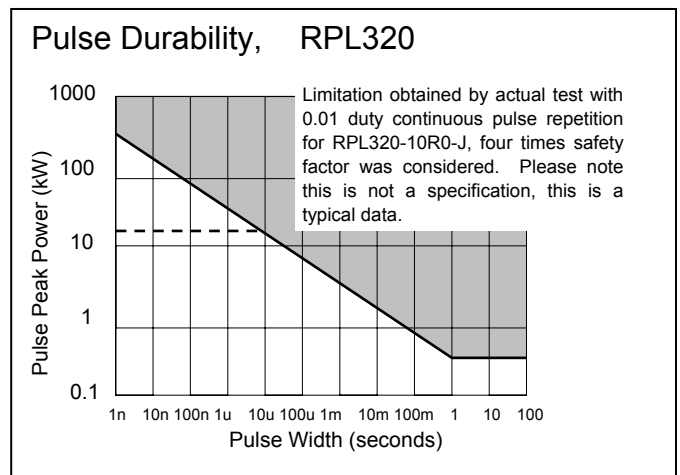
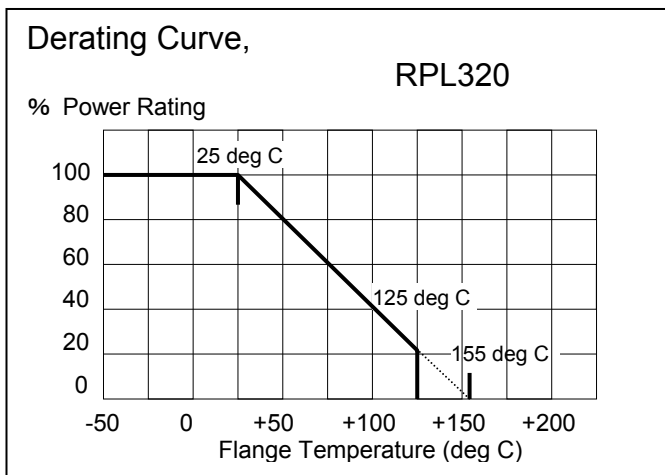

Materials

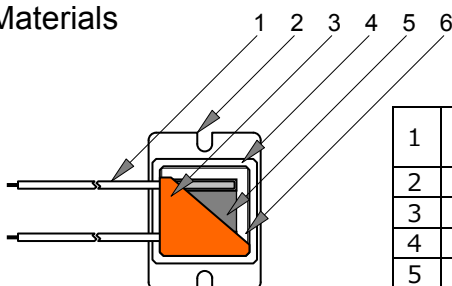

1	Terminals	Silicone insulated wires. 2-0.75sqmm, 30/0.18mm, Silicone rubber insulated cable, UL:VW-1 (or 2-0.30sqmm)
2	Flange	Ni plated copper plate.
3	Mold	Silicone rubber insulator
4	Case	PA6 side wall
5	Resistor	Metal film resistor
6	Substrate	Al ₂ O ₃ alumina substrate

20160501

300W

CHASSIS MOUNTING NON-INDUCTIVE
QUICK CONNECT HIGH POWER RESISTORS

RPL320F

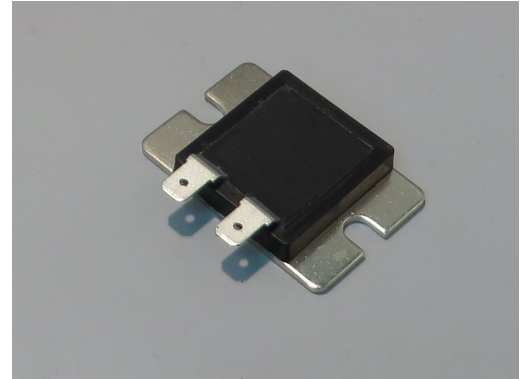

Features and Applications

Quick connect, flat type, 300W high power resistor. Attaching an air-cooled heat sink or water-cooling necessary.

300W rated power at 25°C and 175 °C maximum operating temperature.

#187 quick connect tab terminals provide easy to assemble.

Higher density packing, vibration-proof, insulation withstand voltage and perfect heat dissipation possible.

Applications include harmonic filter, snubber resistors, surge protection, breeder resistor, dummy load, gate resistor, dumping resistor for automotive electronics, power supplies, pulse generators, high frequency amplifiers, theater audio equipment and power electronics.

Dimensions

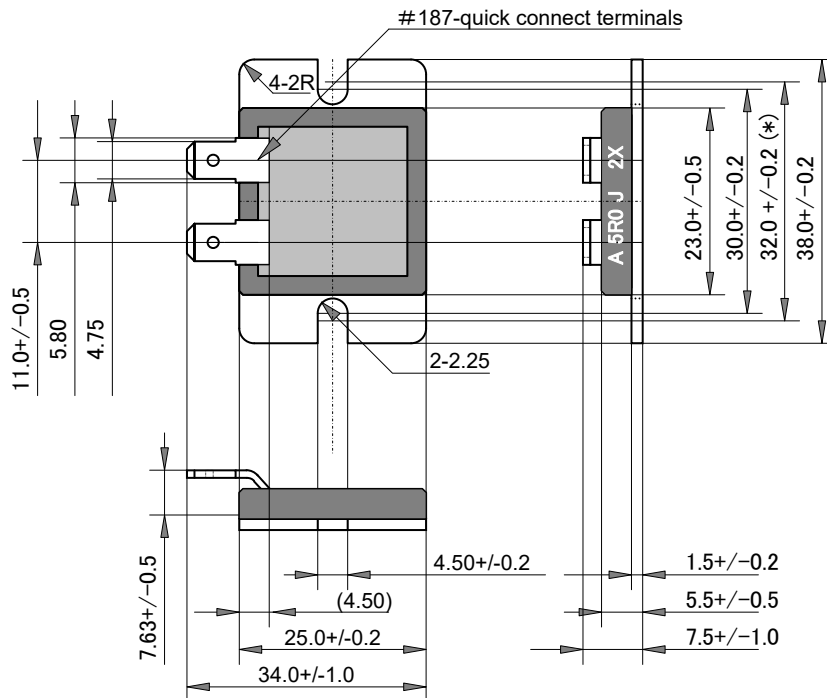

RPL320F

300W

RPL320F

CHASSIS MOUNTING NON-INDUCTIVE FLAT TYPE HIGH POWER RESISTORS

Ordering Information

Type RPL320F	TCR A	Resistance 10R0	Tolerance J	Code Z05	Note
RPL320F	A (100ppm)	10 ohm	J (5%)	Z05	RoHS, tray package
		E24+ (*)			

(*)Resistance value is available following modified E24, +E24, when request for optional resistance please call factory.

1.0	1.1	1.2	1.3	1.5	1.6	1.8	2.0	2.2	2.4	2.5	2.7	3.0	3.3
3.6	3.9	4.0	4.3	4.7	5.0	5.1	5.6	6.2	6.8	7.5	8.0	8.2	9.1

Specifications and Performances

--	Specifications	Conditions
Rating Power	300 Watts	At flange temperature -55°C to +25 °C
Heat Resistance	0.23 °C/W	From resistor to flange
Resistance Range	0.1 ohm to 1Mohm	Lowest 0.1 ohm is available, 0.1ohm – 1Mohm
Nominal Resistance	E24+	Modified E24, additionally, 2.0 and 5.0.
TCR	+/-100 ppm/K (A)	For -55 to +175 °C
Tolerance	+/-5% (J)	
Operation Temp.	-55°C to +175°C	At flange element surface
Max. Applied Voltage	$E = \sqrt{P \cdot R}$ or 1000V	
Withstanding Voltage	2000 VAC	60 seconds between terminals and flange. Leak current below 0.5mA
Load Life	□R+/-1.0 %	Continuous power 1000hours.
Humidity	□R+/-1.0 %	60 °C, 90 to 95%RH, DC0.1W, 1000hours.
Temperature Cycle	□R+/-1.0 %	-55 °C, 30 min., +155 °C 30min., 5 cycles.
Insulation Resistance	Over 1000 Meg ohm	Between terminals and flange.
Vibration	□R+/-0.5 %	Note 2
Flammability	UL94V-0	For resistor body
Weight	24 grams	

Note 1: Torque: Mounting 1.6Nm max, 1.0Nm recommend.

Note 2: IEC60068-2-6, displacement 0.75mm or acceleration 100m/sec², 10Hz-54Hz sweep, 10 cycles X-Y-Z direction.

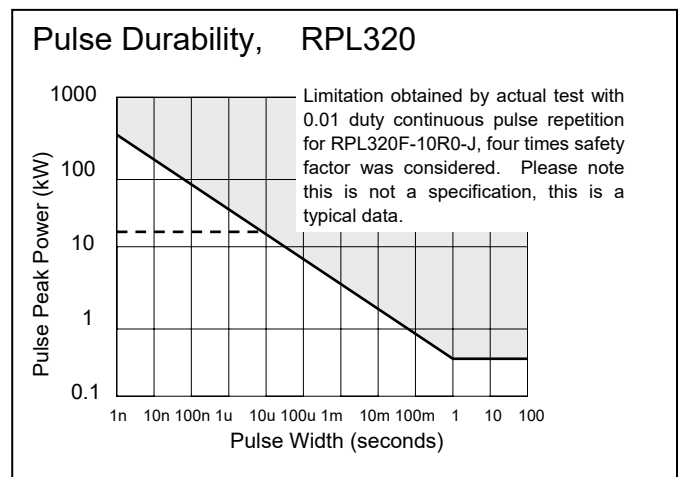
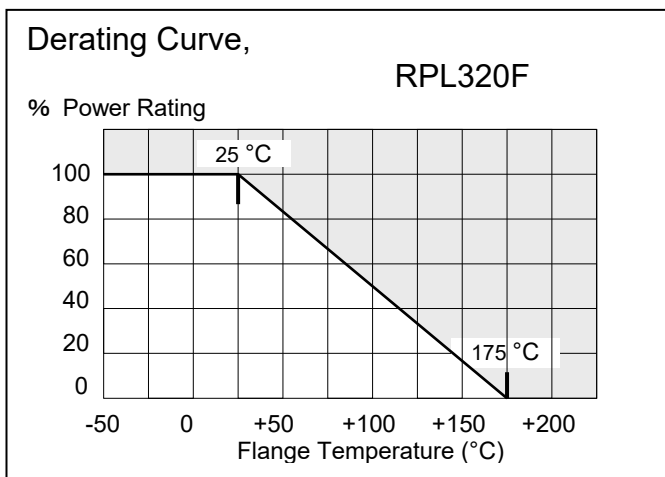

Materials

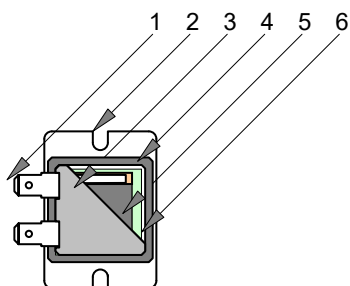

1	Terminals	#187tab terminals
2	Flange	Ni plated copper
3	Molding	Epoxy resin
4	Case	Glass fiber filled PA6 resin
5	Resistor	Thick film
6	Substrate	Alumina ceramics

900W
CHASSIS MOUNTING NON-INDUCTIVE
HIGH POWER RESISTORS

RPK900



Features and Applications

Small size SOT227, 900W high power resistor. Attaching with a large forced air-cooled heat sink or liquid-cooling would be necessary for high power operation.
 Rated power is 900W (single resistor at 25 °C flange temperature), dual resistor configuration is optionally available with 600W (total of dual resistors at 25 °C flange temperature). Please see RPK600.
 M4 screw terminals, very low series inductance.
 Higher density packing, vibration-proof and perfect heat dissipation are available.
 Applications include snubber resistors, breeder resistor, power voltage divider, dumping resistor, braking resistor for X-ray, MRI, Laser power source and etc.

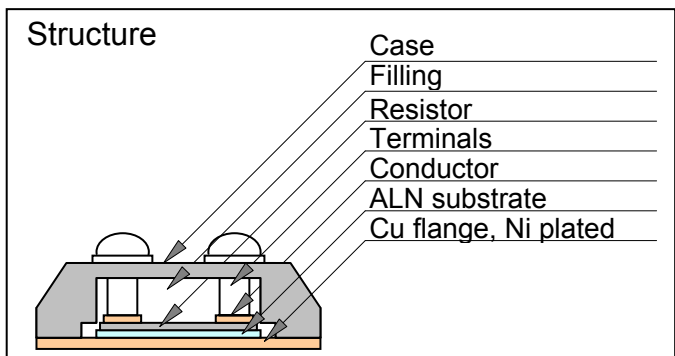
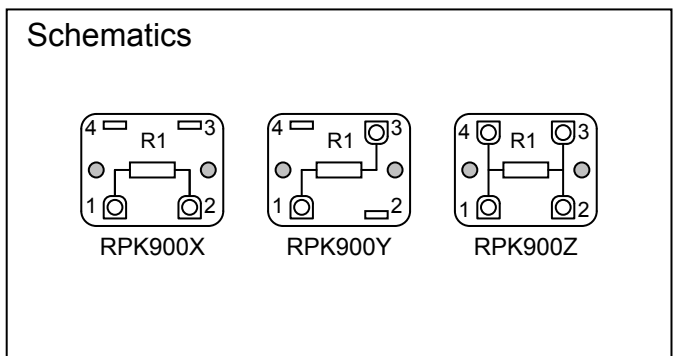
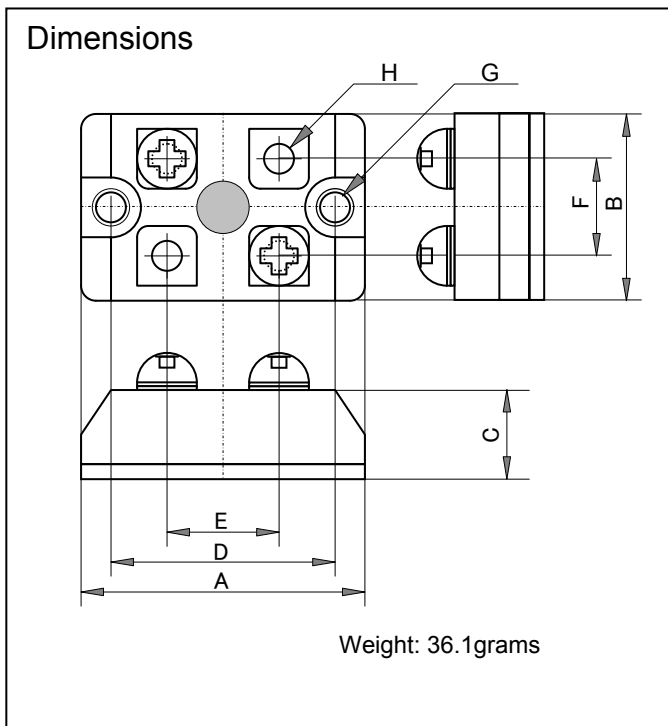

Symbols	(mm)	(inch)
A	38+/-0.5	1.50+/-0.02
B	25+/-0.5	0.98+/-0.02
C	15+/-0.5	0.59+/-0.02
D	30+/-0.2	1.18+/-0.008
E	15+/-0.5	0.59+/-0.02
F	13+/-0.5	0.51+/-0.02
G	2 - 4.20+/-0.1 dia.	2 - 0.165+/-0.004 dia.
H	4 - M4.0	4 - M4.0 (mm)

900W

CHASSIS MOUNTING NON-INDUCTIVE HIGH POWER RESISTORS

RPK900

Ordering Information

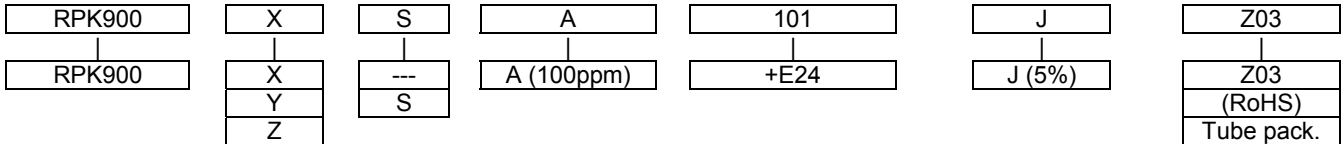

'S' shows supplied terminal screws

Resistance value is available following modified E24, +E24. Another is available optionally.

1.0	1.1	1.2	1.3	1.5	1.6	1.8	2.0	2.2	2.4	2.5	2.7	3.0	3.3
3.6	3.9	4.0	4.3	4.7	5.0	5.1	5.6	6.2	6.8	7.5	8.0	8.2	9.1

Specifications and Performances

Specification Items	RPK900X/Y/Z	Conditions
Rating Power	900 Watts	At flange temperature -55 to +85 °C
Thermal Resistance	0.10 °C/W	Between resistor to flange
Resistance Range	25 ohm to 1K ohm Single	Not available under 25 ohms.
Nominal Resistance	Modified E12	Any value, option
TCR	+/-100 ppm/K (A)	For -55 to +155 °C
Tolerance	+/-5% (J)	Not available +/- 1% (F) tolerance
Operation Temp. Range	-55 - +155 °C	
Limiting Voltage	700V	Less than $E = \sqrt{P \cdot R}$
Withstanding Voltage	2500 VAC	60 seconds. 5000VAC available
Capacitance	13.1 pF	Parallel capacitance at 10MHz
Inductance	13.7 nH	Series inductance at 10MHz
Load Life	+/- (1.0 % + 0.05 ohm)	25°C, 90min.ON, 30min.OFF, 1000hours.
Humidity	+/- (1.0 % + 0.05 ohm)	70°C, 90 to 95%RH, DC0.1W, 1000hours.
Temperature Cycle	+/- (1.0 % + 0.05 ohm)	-55°C, 30 min., +125°C 30min., 20cycles. (-55°C, 30 min., +120°C, 30min., 5 cycles.)
Short Time Overload	+/- (5.0 % + 0.05 ohm)	Rating watt×1.5, 5seconds, with heat sink.
Soldering Heat	---	
Solder ability	Soldering is not available	-
Insulation Resistance	Over 1000 meg ohm	Between terminals and flange.
Vibration	+/- (0.25 % + 0.05 ohm)	

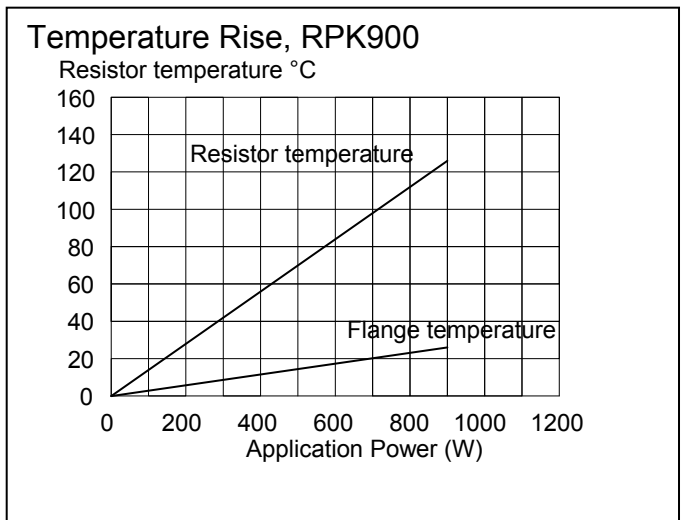
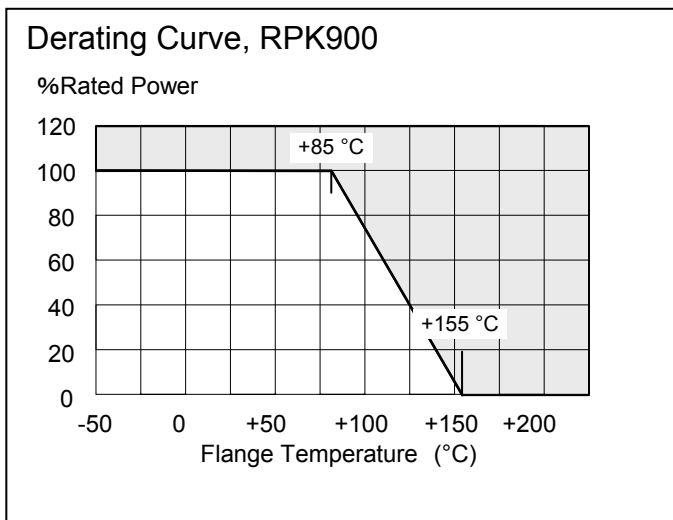

900W

CHASSIS MOUNTING NON-INDUCTIVE HIGH POWER RESISTORS

RPK900

Pulse Operation

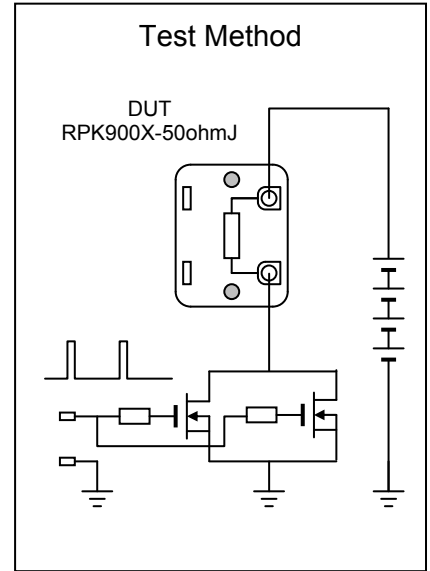
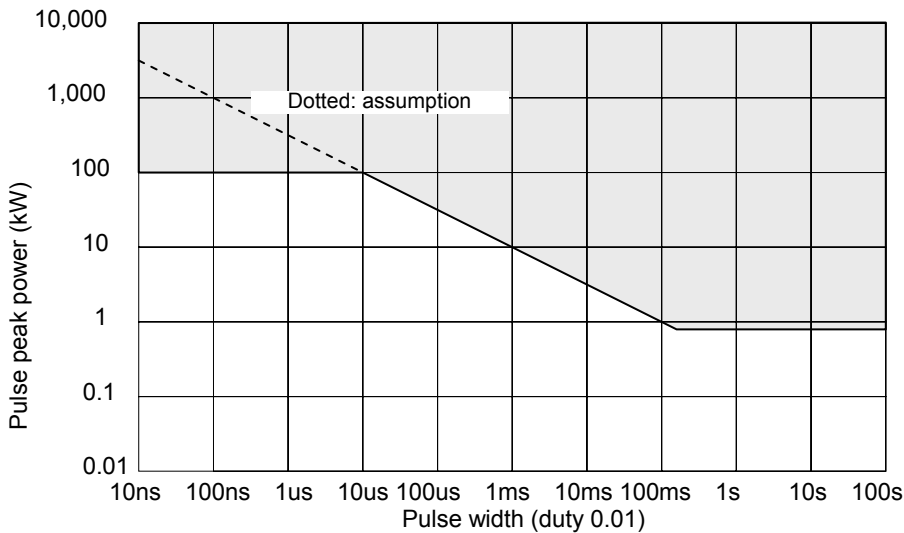

Above drawing shows allowable pulse peak power that obtained by actual breaking test of RPK900Z-10ohm-J, and shows the result of double safety factor. The test was performed by observation of small resistance change after application of continuous pulse, that is rectangular waveform and 0.01 duty.

Since the pulse durability is moved by the resistance, the pulse waveforms and type of pulse source, constant voltage source or current source, please test carefully for long terms on actual electronics when operating the resistor by the pulse of the peak power exceeding rated power.

DC/AC rms Operation

Resistor generates Joule heat in DC or AC rms operation at resistor material, and Joule heat shall be cooled by thermal conduction. Finally, the heat is transported to the internal air electronics or cooling liquid, makes a steady state. Then, the temperature of each portion of a resistor shows a fixed value, as shown in a right figure.

Accumulated heat resistance between resistor material and air temperature R_t is,

$$R_t = R_{rf} + R_{rfh} + R_{rha}$$

When applied power shows P

$$R_{rf} = (t_r - t_f) / P \dots \dots \dots 0.10^\circ \text{ C/W}$$

$$R_{rfh} = (t_f - t_h) / P \dots \dots \dots \text{about } 0.01^\circ \text{ C/W}$$

$$R_{rha} = (t_h - t_a) / P \dots \dots \dots \text{depends on size of heat sink.}$$

For example:

When $R_{rha} = 6.0^\circ \text{ C/W}$, $t_a = 50^\circ \text{ C}$, max resistor temperature 155° C and allowable power P_1 ,
 $P_1 = (t_r - t_a) / R_t = (155 - 50) / (0.1 + 0.01 + 6.0) = 17.1 \text{ W}$

When $R_{rha} = 0.1^\circ \text{ C/W}$, $t_a = 50^\circ \text{ C}$, max resistor temperature 155° C and allowable power P_2 ,
 $P_2 = (t_r - t_a) / R_t = (155 - 50) / (0.1 + 0.01 + 0.1) = 500 \text{ W}$

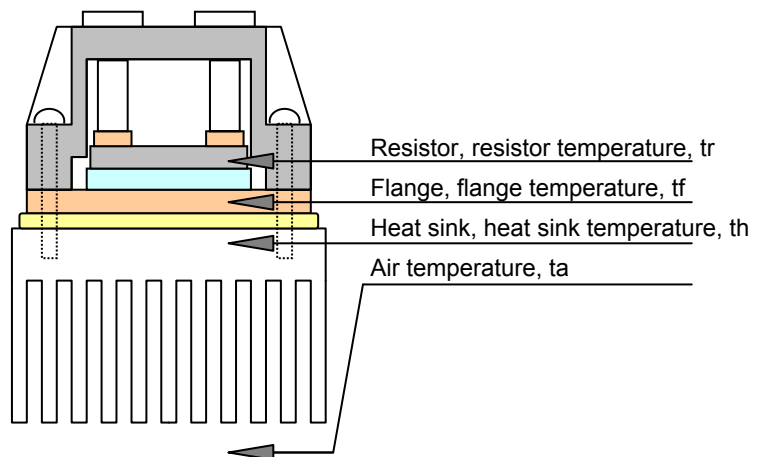

Please note, when air cool heat sink is used, actually keeping flange at less than 25° C is difficult. When flange temperature is over 25° C , rating will be decreased as shown above derating curve.

In DC operation, allowable power depends on a cooling performance of the heat sink.

900W
 CHASSIS MOUNTING NON-INDUCTIVE
 HIGH POWER RESISTORS,
 WATER COOLING

RPK900L

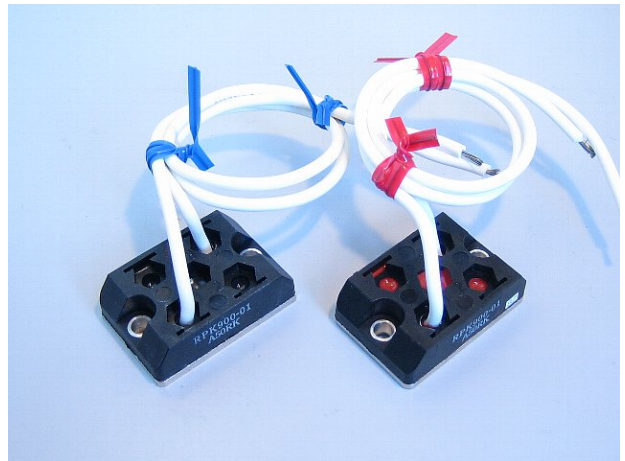

Features and Applications

Small size SOT227, 900W high power resistor. Attaching with a large forced air-cooled heat sink or liquid-cooling would be necessary for high power operation.
 Rated power is 900W with 10kV - 50Hz insulation voltage and 7kV - 50kHz corona discharge.
 M4 screw terminals, very low series inductance and capacitance.
 Higher density packing, vibration-proof and perfect heat dissipation are available.
 Applications include charge / discharge resistors, voltage divider of the high voltage pulse source for X-ray CT, MRI, EUV Laser and etc.

Dimensions and Materials

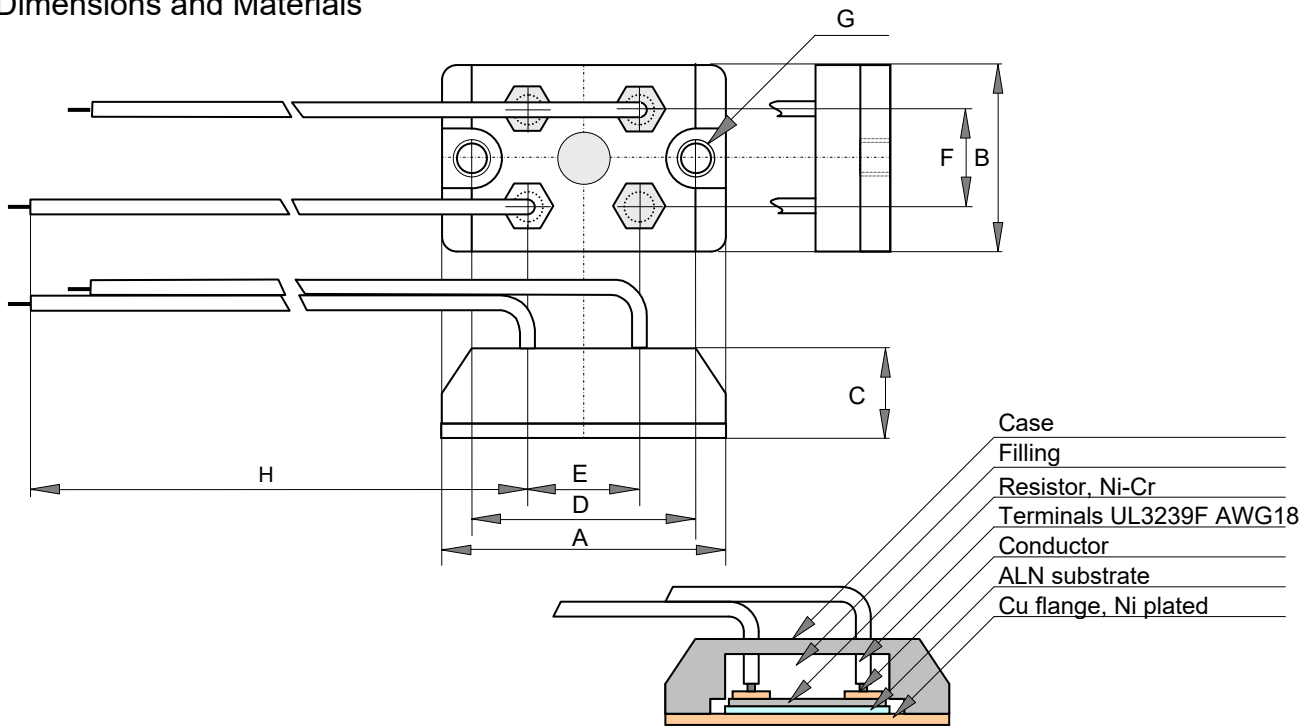

	(mm)	(inch)
A	38+/-0.5	1.50+/-0.02
B	25+/-0.5	0.98+/-0.02
C	12+/-0.5	0.47+/-0.02
D	30+/-0.2	1.18+/-0.008
E	15+/-0.5	0.59+/-0.02
F	13+/-0.5	0.51+/-0.02
G	2 - 4.20+/-0.1 dia.	2 - 0.165+/-0.004 dia.
H	250+/-10	9.8+/-0.4

900W

CHASSIS MOUNTING NON-INDUCTIVE HIGH POWER RESISTORS

RPK900L

Ordering Information

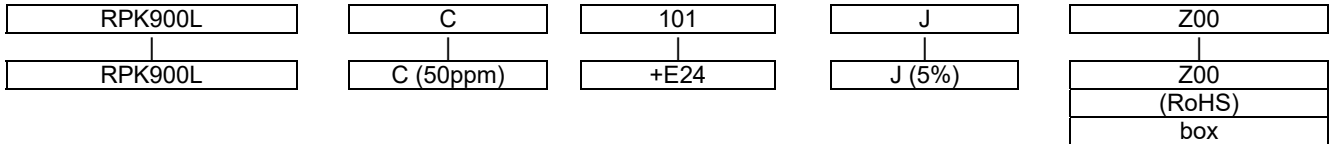

Resistance value is available following modified E24, +E24. Another is available optionally.

1.0	1.1	1.2	1.3	1.5	1.6	1.8	2.0	2.2	2.4	2.5	2.7	3.0	3.3
3.6	3.9	4.0	4.3	4.7	5.0	5.1	5.6	6.2	6.8	7.5	8.0	8.2	9.1

Specifications and Performances

Specification Items	RPK900L	Conditions
Rating Power	900 Watts	At flange temperature -55 to +25 °C
Thermal Resistance	0.10 °C/W	Between resistor to flange
Resistance Range	25 ohm to 1K ohm Single	
Nominal Resistance	Modified E24	Any value, option
TCR	+/- 50 ppm/°C (C)	For -55 to +155 °C
Tolerance	+/-5% (J)	available +/- 1% (F) option
Operation Temp. Range	-55 - +155 °C	
Limiting Voltage	Either less than 1000V or $E = \sqrt{P \cdot R}$	
Withstanding Voltage	10,000 VAC	60 seconds - 0.5mA - 50Hz
Partial discharge	7,000 V - 50kHz	Starting voltage, typical
Capacitance	13.1 pF	Parallel capacitance at 10MHz, short wire leads
Inductance	13.7 nH	Series inductance at 10MHz, short wire leads
Load Life	+/- (1.0 % + 0.05 ohm)	25°C, 90min.ON, 30min.OFF, 1000hours.
Humidity	+/- (1.0 % + 0.05 ohm)	70°C, 90 to 95%RH, DC0.1W, 1000hours.
Temperature Cycle	+/- (1.0 % + 0.05 ohm)	-55°C, 30 min., +125°C 30min., 20cycles. (-55°C, 30 min., +120°C, 30min., 5 cycles.)
Short Time Overload	+/- (5.0 % + 0.05 ohm)	Rating watt×1.5, 5seconds, with heat sink.
Insulation Resistance	Over 1000 meg ohm	Between terminals and flange.
Vibration	+/- (0.25 % + 0.05 ohm)	
Weight	38 grams	Without wire terminals

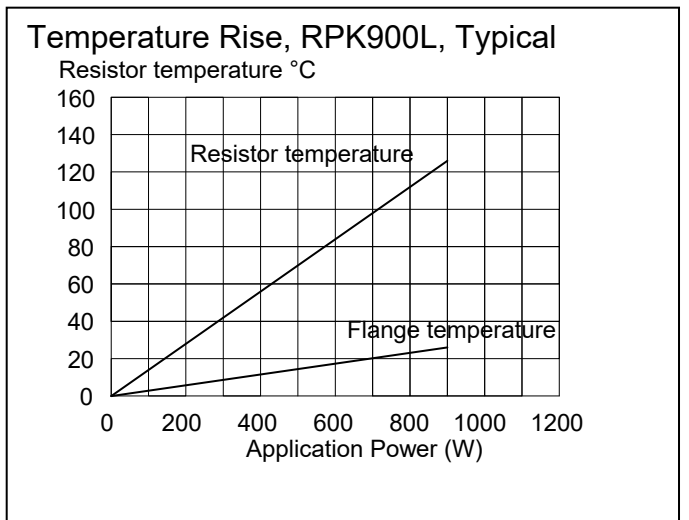
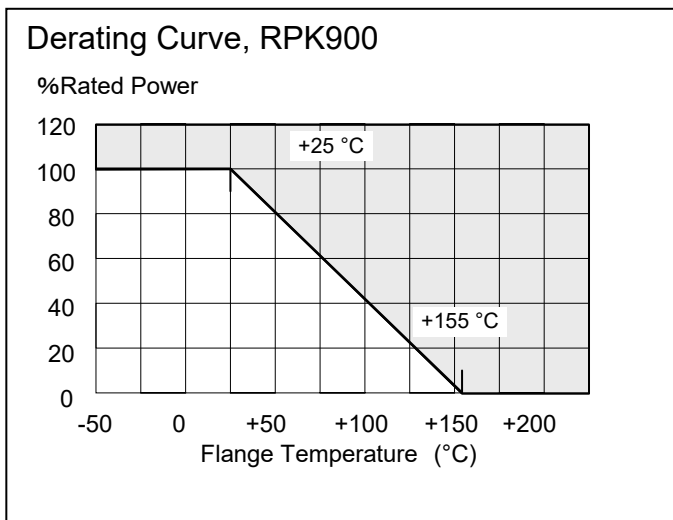

900W

CHASSIS MOUNTING NON-INDUCTIVE HIGH POWER RESISTORS

RPK900L

Pulse Operation

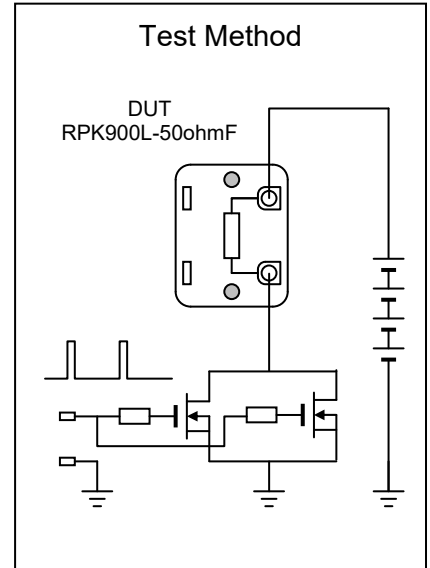
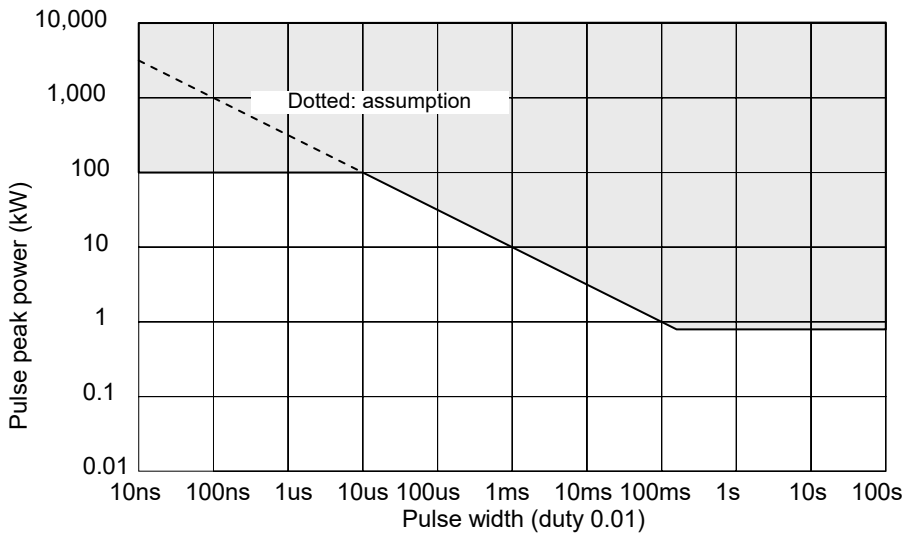

Above drawing shows allowable pulse peak power that obtained by actual breaking test of RPK900L-10ohm-J, and shows the result of double safety factor. The test was performed by observation of small resistance change after application of continuous pulse, that is rectangular waveform and 0.01 duty.

Since the pulse durability is moved by the resistance, the pulse waveforms and type of pulse source, constant voltage source or current source, please test carefully for long terms on actual electronics when operating the resistor by the pulse of the peak power exceeding rated power.

Typical High speed pulse power generator and water cooling resistor, RPK900L

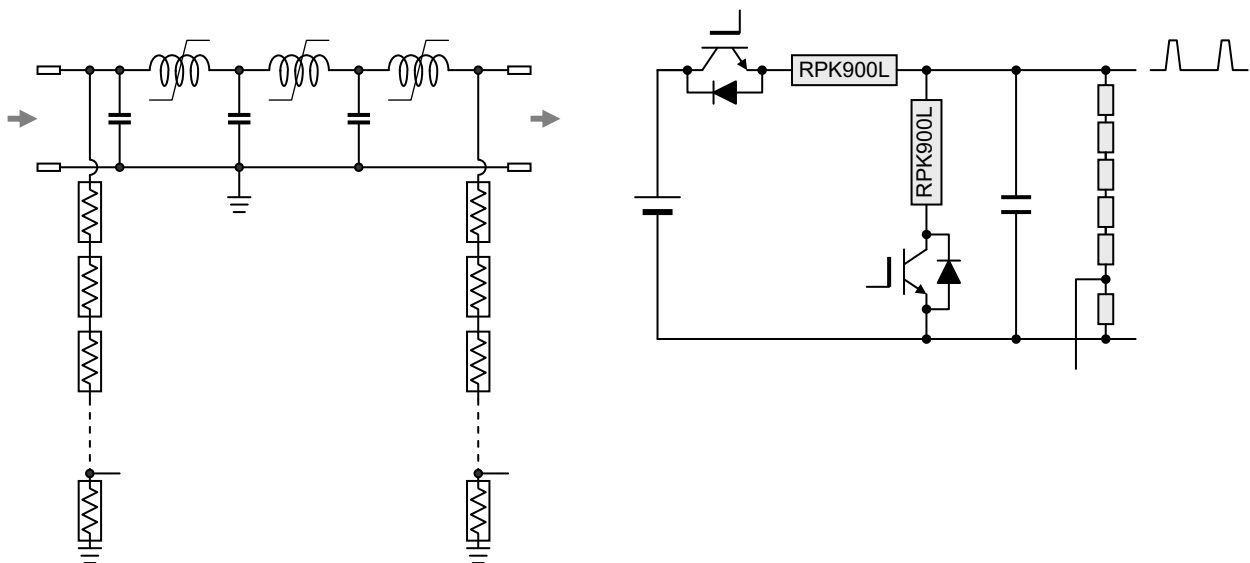

Typical High speed pulse power generator and water cooling resistor, RPK900L

800W
 WATER COOLING
 CHASSIS MOUNTING
 NON-INDUCTIVE,
 HIGH VOLTAGE,
 HIGH POWER RESISTORS

RPU800

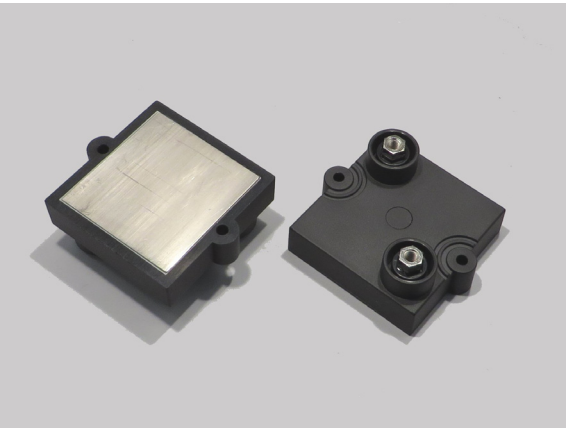

Features and Applications

Low profile flat type, 800W high power resistor. Attaching large air-cooled heat sink or water-cooling necessary.

8kV insulating voltage and starting voltage of typical 5kV - 30kHz partial discharge.

Higher density packing, vibration-proof, insulation withstand voltage and perfect heat dissipation possible. Applications include snubber resistors, surge protection, breeder resistor, harmonic filter resistor, dummy load, gate resistor, dumping resistor for power supplies, pulse generators, high frequency amplifiers, theater audio equipment, etc.

Dimensions and Structure

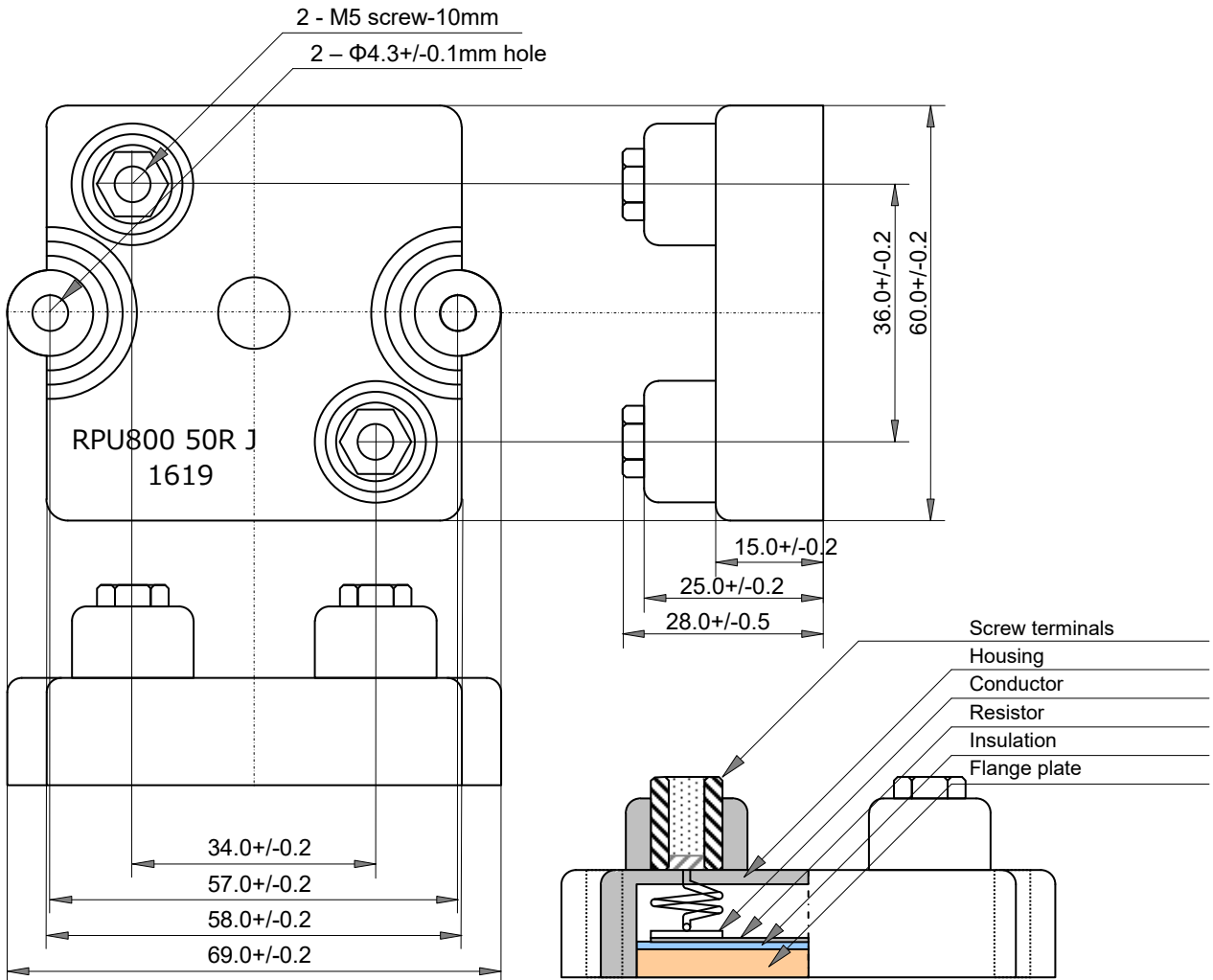

800W

RPU800

CHASSIS MOUNTING NON-INDUCTIVE HIGH POWER RESISTORS

Ordering Information

Type RPU800	TCR ---	Resistance 101	Tolerance J	Code Z00	Note
RPU800	---	101	J (5%)	Z00	RoHS, Box Package
		E24+ (*)			

(*) Standard resistance value, E24+

1.0	1.1	1.2	1.3	1.5	1.6	1.8	2.0	2.2	2.4	2.5	2.7	3.0	3.3
3.6	3.9	4.0	4.3	4.7	5.0	5.1	5.6	6.2	6.8	7.5	8.0	8.2	9.1

Specifications and Performances

Items	Performances	Conditions
Rated Power	800 Watts	At flange temperature -55 to +90°C
Short-time Overload	1200 Watts	5 seconds mounted on cooler
Heat Resistance	0.10 °C /W	From resistor to flange
Resistance Range	0.5Ω to 1 MΩ	
Nominal Resistance	E24+	Additionally, 2.0 and 5.0.
TCR	+/-100 ppm/K (A)	At 1.0Ω-1MΩ, +/-200ppm/°C at <1.0Ω, for -55 to +155 °C
Tolerance	+/-5% (J)	
Operation Temp.	-55 to +175 °C	At resistor element surface
Max. Applied Voltage	5000V or $E = \sqrt{P \cdot R}$	P shows rated power (W), R resistance value (Ohms), E voltage (V)
Insulation Voltage	8,000 V – 50 Hz	60 seconds between terminals and flange. Leak current below 0.5mA
Capacitance	73 pF	Resistor terminal - flange
Inductance	108 nH	Resistor terminal - Terminal
Capacitance	25 pF	Resistor terminal - Terminal
Creeping distance	42mm	
Air distance	14mm	
Load Life	ΔR +/-0.40 %	Continuous power 1000hours.
Humidity	ΔR +/-0.25 %	60 °C, 90 to 95%RH, DC0.1W, 1000hours.
Temperature Cycle	ΔR +/-0.20 %	-55 °C, 30 min., +155 deg C 30min., 5 cycles.
Insulation Resistance	Over 1 GΩ	Between terminals and flange., DC 1000V
Vibration	ΔR +/-0.25 %	Note 2
Flammability	UL94V-0	For resistor body
Weight	168 grams	

Note 1: Torque: Mounting 1.8 Nm-M4, contacts 2.0Nm-M5 recommend.

Note 2: IEC60068-2-6, displacement 0.75mm or acceleration 100m/sec², 10Hz-54Hz sweep, 10 cycles X-Y-Z direction.

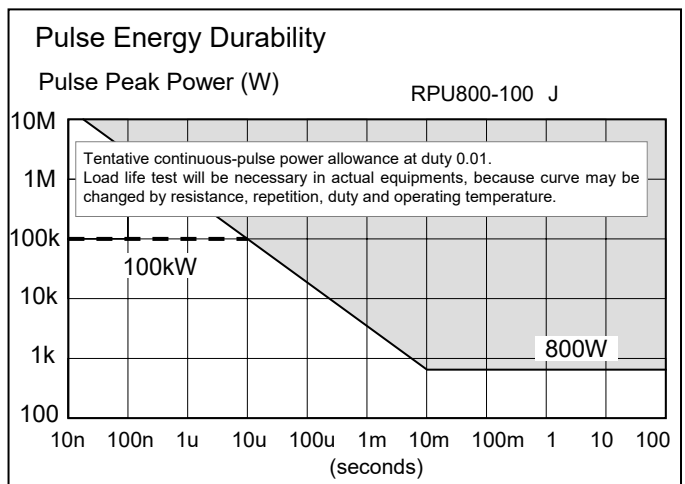
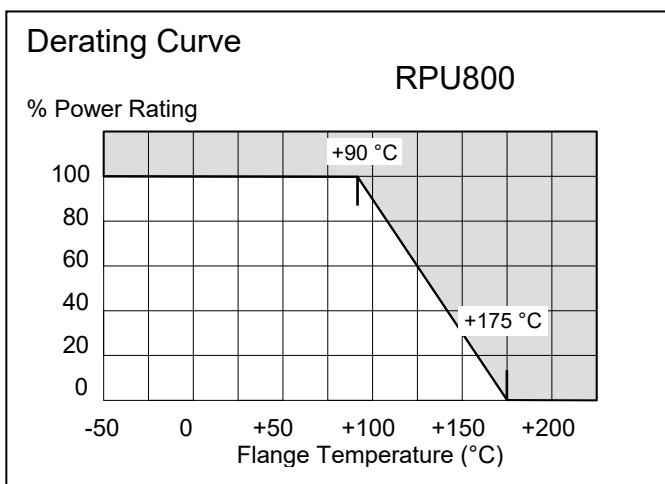

Note:

1000W - 8kV INSULATION
 WATER COOLING,
 CHASSIS MOUNTING,
 NON-INDUCTIVE,
 HIGH VOLTAGE,
 HIGH POWER RESISTORS

RPU1000

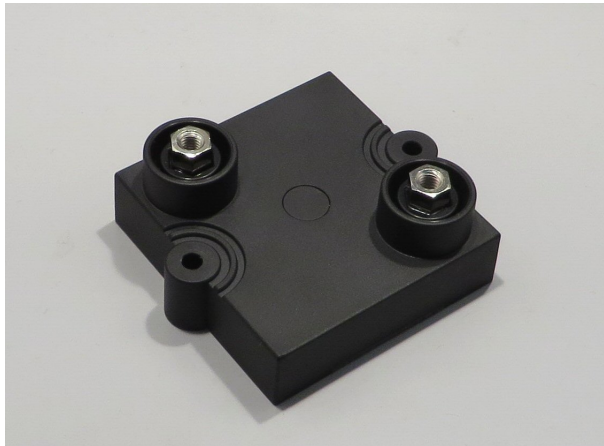

Features and Applications

Low profile flat type, 1000W high power resistor. Attaching large air-cooled heat sink or water-cooling operation.

8kV insulation voltage and starting voltage of 5kV - 50kHz partial discharge.

Higher density packing, vibration-proof, insulation withstand voltage and perfect heat dissipation possible. Applications include harmonic filter resistors, snubber resistors, surge protection, breeder resistor, dummy load, dumping resistor for heavy duty power electronics, power supplies, pulse generators, high frequency amplifiers, theater audio equipment, etc.

Dimensions and Structure (mm)

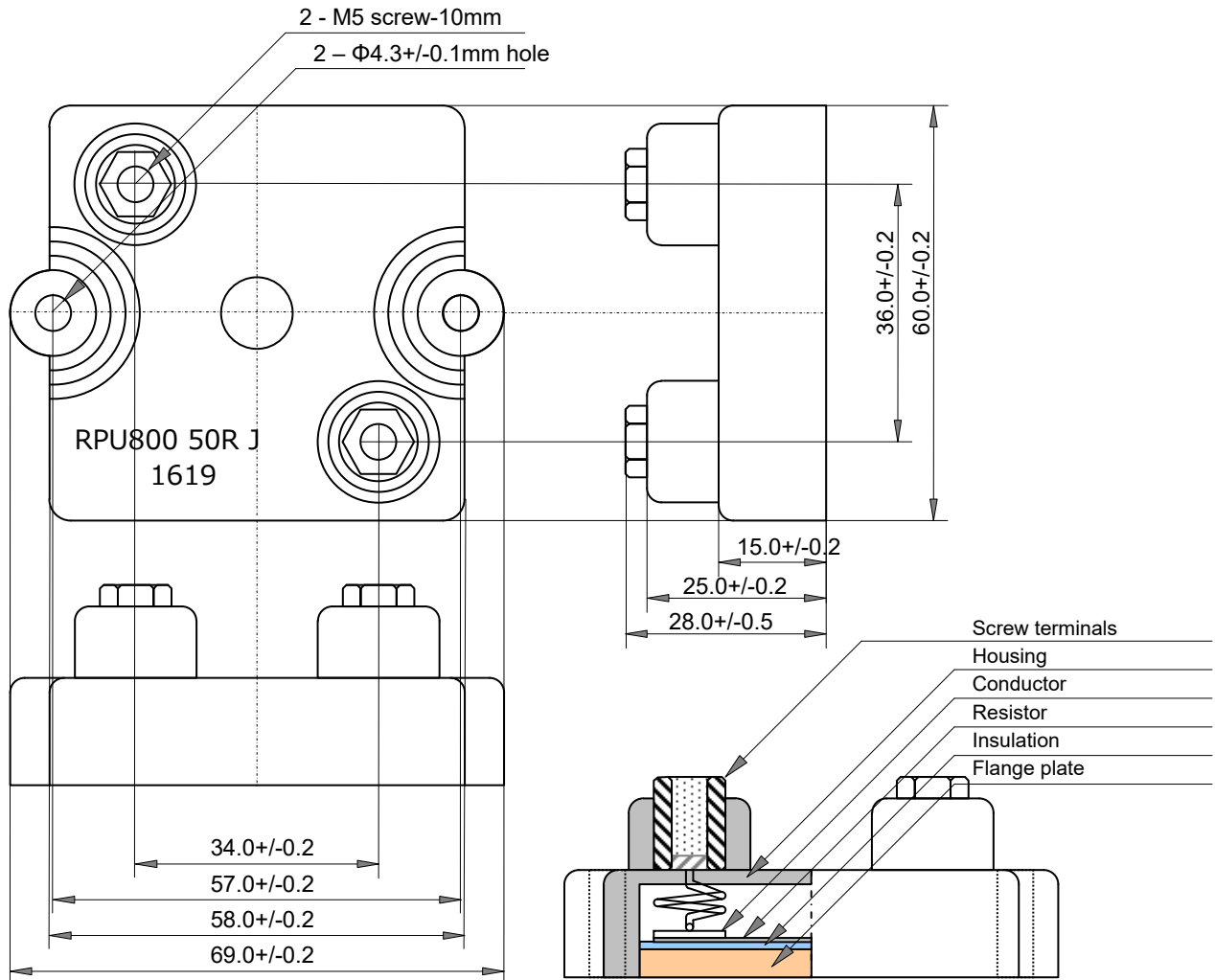

1000W

RPU1000

CHASSIS MOUNTING NON-INDUCTIVE HIGH POWER RESISTORS

Ordering Information

Type RPU1000	TCR ---	Resistance 101	Tolerance J	Code Z00	Note
RPU1000	---	101	J (5%)	Z00	RoHS, Box Package
		E24+ (*)			

(*) Standard resistance value, E24+

1.0	1.1	1.2	1.3	1.5	1.6	1.8	2.0	2.2	2.4	2.5	2.7	3.0	3.3
3.6	3.9	4.0	4.3	4.7	5.0	5.1	5.6	6.2	6.8	7.5	8.0	8.2	9.1

Specifications and Performances

Items	Performances	Conditions
Rated Power	1000 Watts	At flange temperature -55 to +75°C
Short-time Overload	1200 Watts	5 seconds with heat sink
Heat Resistance	0.10 °C /W	From resistor to flange
Resistance Range	0.5Ω to 1 MΩ	
Nominal Resistance	E24+	Additionally, 2.0 and 5.0.
TCR	+/-100 ppm/K (A)	At 1.0Ω-1Mohm, +/-200ppm/°C at <1.0ohm, for -55 to +155 °C
Tolerance	+/-5% (J)	
Operation Temp.	-55 to +175 °C	At resistor element surface
Max. Applied Voltage	5000V or $E = \sqrt{P \cdot R}$	P shows rated power (W), R resistance value (ohm), E voltage (V)
Insulation Voltage	8,000 V - 50 Hz	60 seconds between terminals and flange. Leak current below 0.5mA
Capacitance	73 pF	Resistor terminal - flange
Inductance	108 nH	Resistor terminal - Terminal
Capacitance	25 pF	Resistor terminal - Terminal
Creeping distance	42mm	
Air distance	14mm	
Load Life	ΔR+/-0.40 %	Continuous power 1000hours.
Humidity	ΔR+/-0.25 %	60 °C, 90 to 95%RH, DC0.1W, 1000hours.
Temperature Cycle	ΔR +/-0.20 %	-55 °C, 30 min., +155 deg C 30min., 5 cycles.
Insulation Resistance	Over 1 GΩ	Between terminals and flange., DC 1000V
Vibration	ΔR +/-0.25 %	Note 2
Flammability	UL94V-0	For resistor body
Weight	120 grams	

Note 1: Torque: Mounting 1.8 Nm-M4, contacts 2.0Nm-M5 recommend.

Note 2: IEC60068-2-6, displacement 0.75mm or acceleration 100m/sec², 10Hz-54Hz sweep, 10 cycles X-Y-Z direction.

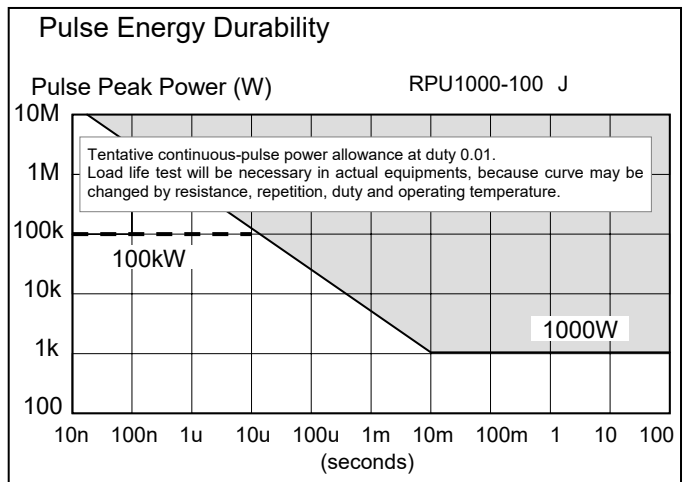
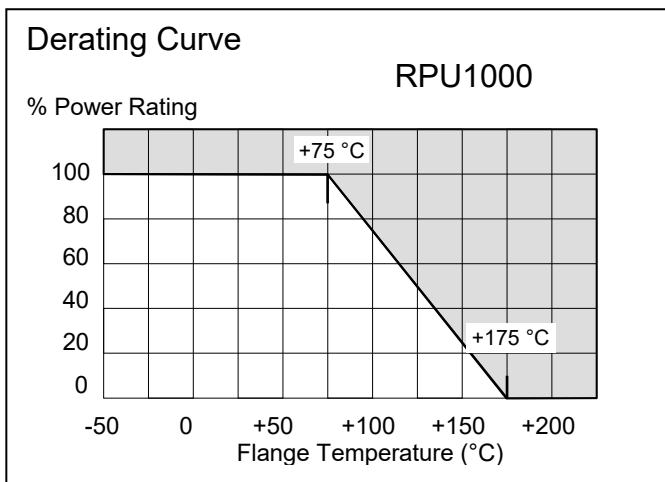

Note:

3W - 14W VITREOUS ENAMEL WIREWOUND RESISTORS

VT-3, VT-5, VT-7, VT-10, VT-14

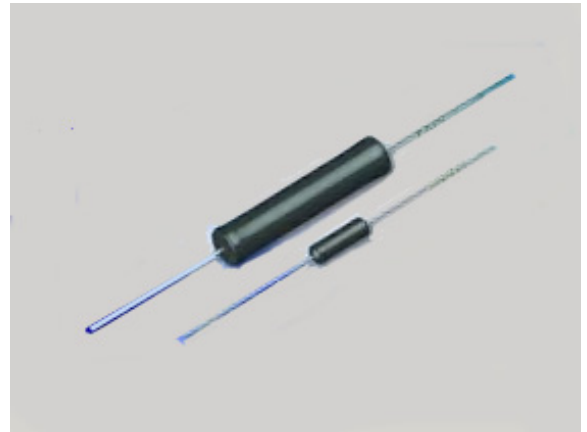

Features and Applications

-55 °C - +350 °C operating temperature glass enamel coated wire wound resistor.
 Wide 0.1Ω to 100kΩ resistance range and 1% tolerance contribute to make circuit design flexibility.
 High overload and pulse handling conform to all power electronics.
 Applications include industrial power electronics, industrial measurements, automatic testing, switching power supplies, motor control electronics, inrush current protection in automotive electronics, industrial power supplies.

Dimensions (mm)

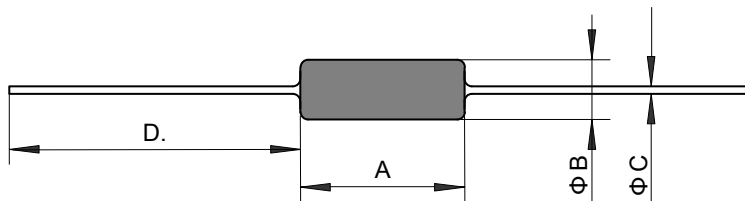

Type	Wattage Rating	Dimension A	Dimension B	Dimension C	Dimension D	Resistance Range Ohms	Maximum Working Voltage (V)
	@25°C	Inch (mm) Max.	Inch (mm) Max.	Inch (mm)	Inch (mm)		
VT-3	3.0	0.500 (12.7)	0.220 (5.6)	0.032 (0.8)	1.05 (26.5)	0.1 - 10k	100
VT-5	5.0	0.906 (23.0)	0.276 (7.0)	0.032 (0.8)	1.05 (26.5)	0.1 - 20k	160
VT-7	7.0	0.874 (22.2)	0.315 (8.0)	0.032 (0.8)	1.05 (26.5)	0.1 - 22k	200
VT-10	10.0	1.500 (38.1)	0.315 (8.0)	0.032 (0.8)	1.38 (35.0)	0.1 - 68k	500
VT-14	14.0	2.106 (53.5)	0.315 (8.0)	0.032 (0.8)	1.38 (35.0)	0.1 - 100k	750

The termination are solderable to a minimum of 2mm from the body. Lead Diameter, 20AWG = 0.032"

Ordering Information

Type	n/a	Resistance	Tolerance	Packaging	Remarks
VT - 3		10 ohm	F	Z00	
VT-3		Any value	F (+/-1.0%)	Z00 (1000 pcs bulk)	Inductive
VT-5		0.1 Ω to	J (+/-5.0%)		
VT-7		Max. value	K (+/-10%)		
VT-10					
VT-14					

Specifications

Specifications	Value
Tolerance	+/-1%, +/-5%, +/-10%
Temperature Coefficient	Standard +200ppm/K, Typical +100ppm/K
Temperature Range	-55°C to 350°C
Dielectric Strength	1500VAC
Construction	Non - flammable Enamel Coating
Environmental Performance	MIL-STD202 ΔR
Dielectric	+/- 1.0% +0.05Ω
Load Life	+/- 5.0% +0.05Ω
Storage	+/- 1.0% +0.05Ω
Moisture Resistance	+/- 5.0% +0.05Ω
Thermal Shock	+/- 1.0% +0.05Ω
10 x Overload, 5 seconds	+/- 1.0% +0.05Ω
Mechanical Shock	+/- 1.0% +0.05Ω
Vibration	+/- 1.0% +0.05Ω

Derating

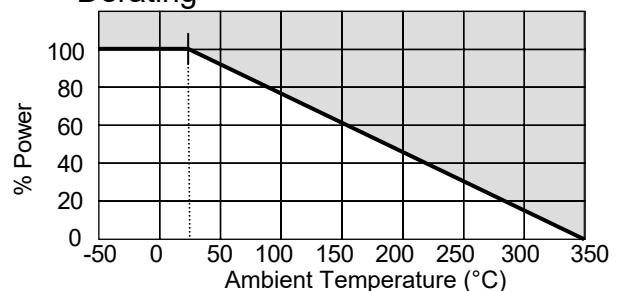

HIGH VOLTAGE RESISTORS

UT



Features and Applications

UT series to meet general set of requirements ultra high voltage and high energy at reasonable price.

UT presents a wide range of resistance value and tolerance.

Applications include electron microscope, X-ray analyzer, high power laser oscillator, MRI, plasma generator, electrostatic coating.

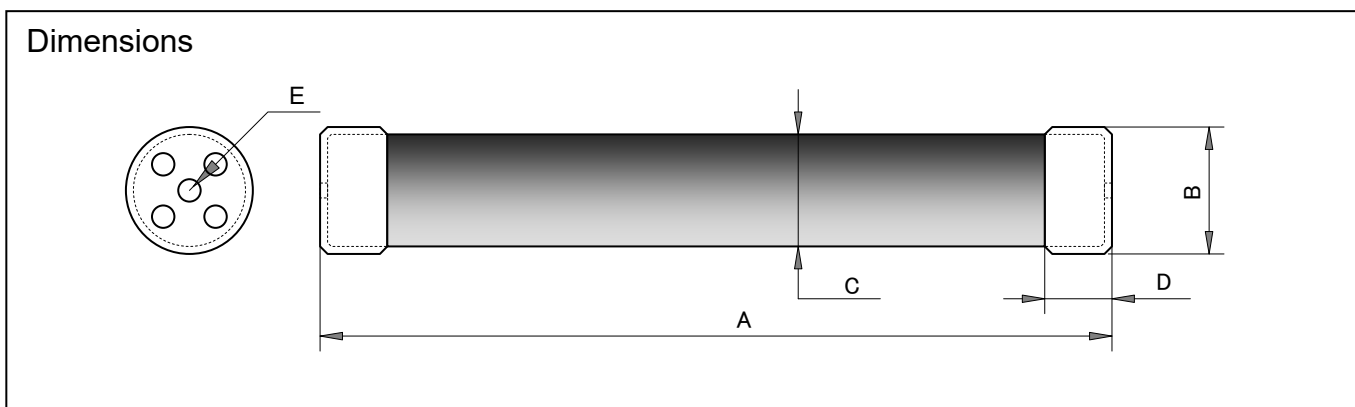

Model	Power (W)	**MAX. Operating Voltage (kV)	A (mm)	B (mm)	C (mm)	D (mm)	E	Dia. of Corona Ring, RC (mm)
UT20	20	40	158+/-1.5	15+/-1.0	14+/-1.0	10+/-1.5	M4	N/A
UT35	35	30	110+/-1.5	33+/-0.5	31+/-1.0	18+/-0.5	M6	43
UT50	50	48	160+/-1.5	33+/-0.5	31+/-1.0	18+/-0.5	M6	43
UT70	70	65	210+/-1.5	33+/-0.5	31+/-1.0	18+/-0.5	M6	43
UT100	100	100	310+/-1.5	33+/-0.5	31+/-1.0	18+/-0.5	M6	43
UT150	150	100	310+/-1.5	33+/-1.0	40+/-1.0	21+/-0.5	M6	56

Cap style; ex. UT100-NC shows normal cap type, UT100-RC shows Corona Ring and Cap type.

Tera-ohm available on request.

Glass coating in standard, epoxy coating available.

The voltage limited by power.

Electrical specification on resistance value of 20kΩ - 1000MΩ only.

Model	Single Impulse Voltage 1.2/50us (kV)	Standard Resistance Value (ohm)	Low Extended Resistance Value (ohm)	High Extended Resistance Value (ohm)	Tolerance
UT20	27	1k - 1G	20R - 0.9k	1.1G - 10T	1%, 5%, 10%
UT35	50	1k - 1G	10R - 0.9k	1.1G - 10T	1%, 5%, 10%
UT50	77	1k - 1G	10R - 0.9k	1.1G - 10T	1%, 5%, 10%
UT70	100	1k - 1G	10R - 0.9k	1.1G - 10T	1%, 5%, 10%
UT100	150	1k - 1G	10R - 0.9k	1.1G - 10T	1%, 5%, 10%
UT150	150	1k - 1G	10R - 0.9k	1.1G - 10T	

HIGH VOLTAGE RESISTOR

UT

Specifications

	Specifications	Conditions
Resistance Tolerance	1%, 5%, 10%	
TCR	+/-100 ppm/°C (A)	Reference +25 °C / -15 to -105 °C
Overload	Max. 0.50%	5 times rated power with applied voltage not to exceed 1.5 times max. continuous operating voltage for 5 seconds.
Thermal Shock	Max. 0.50%	MIL STD 202, Method 107, condition C
Load Life	1.0% typical	Rated power, 1000hours
Moisture Resistance	Max. 0.50%	MIL STD202, Method 106
Insulation Resistance	10 G Ohm minimum	---
Termination Cap Material	Aluminum alloy, Bronz	M4 / M6 Cap and Rug available
Encapsulation	Epoxy / Silicone Conformal / Glass	

Ordering Information

Type UT100	Cap -NC	TCR A	Resistance 1G0	Tolerance F	Code Z00	Note
UT20	NC	A (+/-100ppm)	E12+	F (1%)	Z00	bulk package
UT35	RC			J (5%)		
UT50				K (10%)		
UT70						
UT100						
UT150						

(*) Recommend resistance value, when request for optional resistance please call factory.

1.0	1.2	1.5	1.8	2.2	2.5	2.7	3.3	3.9	4.7	5.0	5.6	6.8	8.2
-----	-----	-----	-----	-----	-----	-----	-----	-----	-----	-----	-----	-----	-----

Derating

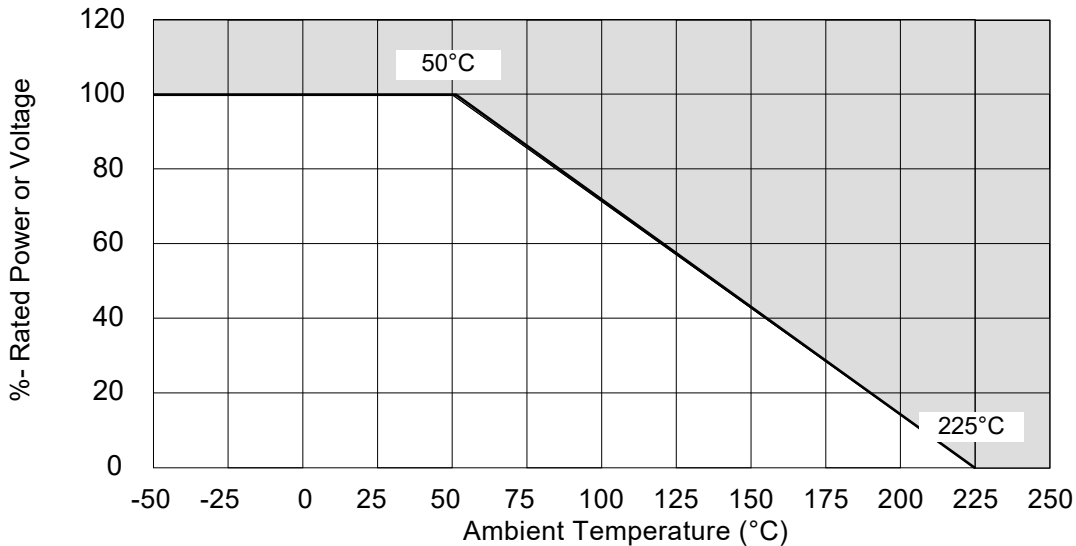

Applications

Automated Test (ATE), Medical (Imaging), Ion Source, Chromatography (Gas), Medical (PET, CT), Medical (Radiation Therapy), Military, Radar, Plasmas, Lasers, Measurements (High Voltage), Capacitor Charging, Microwave (Klystron), Medical (Blood Analyzers), Corona Generators, Multichannel Analyzers, Ozone Generating, Detectors Nuclear, Gamma Cameras, Electron Beam Testing, Surface Analysis, CRT, X-Ray , MRI, Electrophoresis, Image Intensifier, Surface Analysis, Piezo. Focusing (Poling), High Voltage Dividers, Stress Testing, Agricultural Sensors, Ion Beam, Arc Furnace Damping, High Voltage Snubbers, Pulse Forming Networks, Energy Research, EMI, Tube Arc Protection

**SCREW MOUNT NON-INDUCTIVE
HIGH POWER RESISTORS**

RPF-100, RPF-250

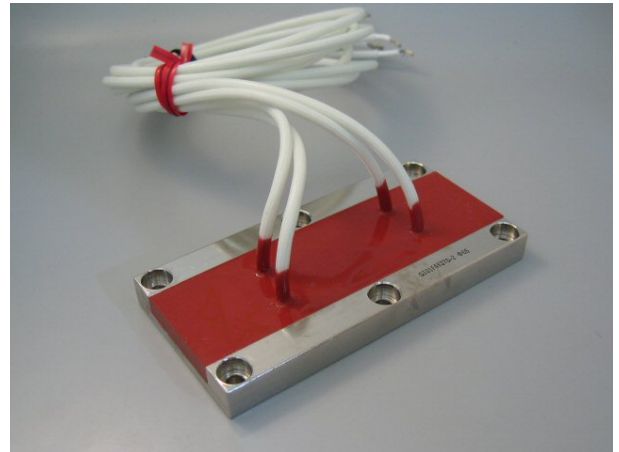

Features and Applications

- Chassis mounting high power resistor of 100W to 250W rating power.
- Small in regard to thickness and with vertical terminal wires so suitable for high density electronic design.
- Also, a decrease in the inductive effect in power electronics circuits will be realized.
- Complete thermal conduction and heat dissipation design will be available.
- Gate resistor and snubber resistor in power supply.
- Load resistor and dumping resistor in high end audio.
- Precision terminal resistor in RF amplifiers.

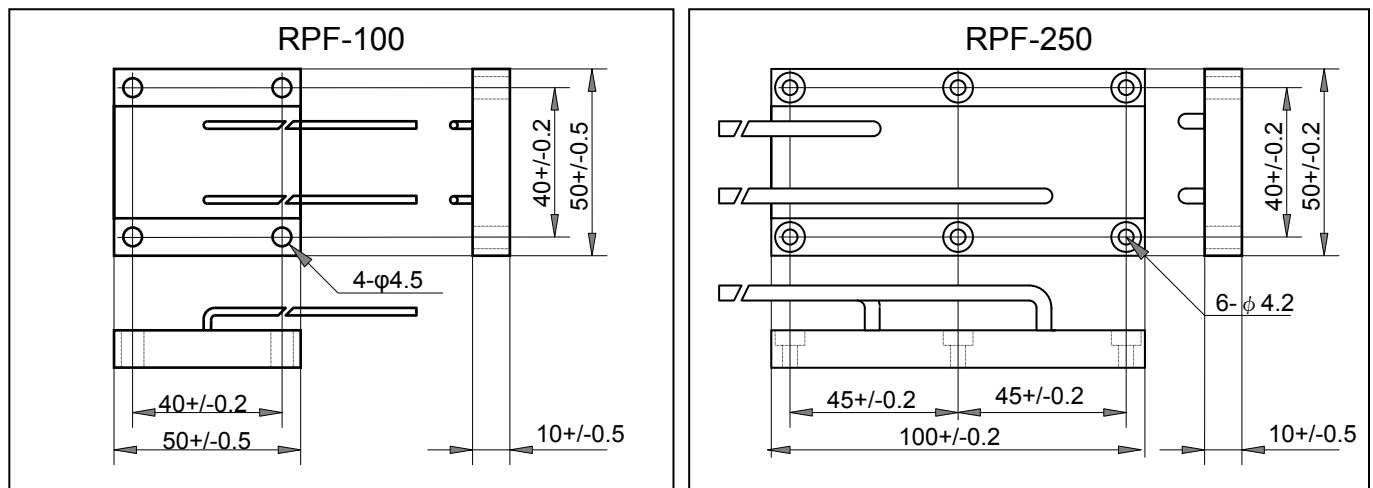

Specifications and Performances

	RPF-100	RPF-250	Test Conditions
Rated Power	100W	250W	
Resistance Range	10ohm~1Kohm	1ohm~1Kohm	
Resistance	E24	E24	Additionally, 2.0 and 5.0.
TCR	±250 ppm/°C	±250 ppm/°C	For -55 to +155 °C
Tolerance	±10%	±10%	
Operation Temp.	-55 - +120 °C	-55 - +120 °C	
Applied Voltage	$E = \sqrt{P \cdot R}$	$E = \sqrt{P \cdot R}$	
Insulation Voltage	5KVAC	5KVAC	60 seconds, 1mA
Load Life	±(1.0 %)	±(1.0 %)	25°C, 90 min.ON, 30min.OFF, 1000hours.
Humidity	±(1.0 %)	±(1.0 %)	40°C, 90~95%RH, DC0.1W, 1000hours.
Temperature Cycles	±(1.0 %)	±(1.0 %)	-55°C, 30 min.,+155°C30min., 20cycles. (-55°C, 30 min.,+120°C30min., 20cycles. at RPF-100)
Short time OVL	±(0.25 %)	±(0.25 %)	Rating watt×2.5, 2.5seconds, with heat sink.
Insulation Resistance	> 1000 Mohm	> 1000 Mohm	Between terminals and tab.
Vibration	±(0.25 %)	±(0.25 %)	
Weight			

500W WATER COOLING NON-INDUCTIVE HIGH POWER RESISTORS

RPH500

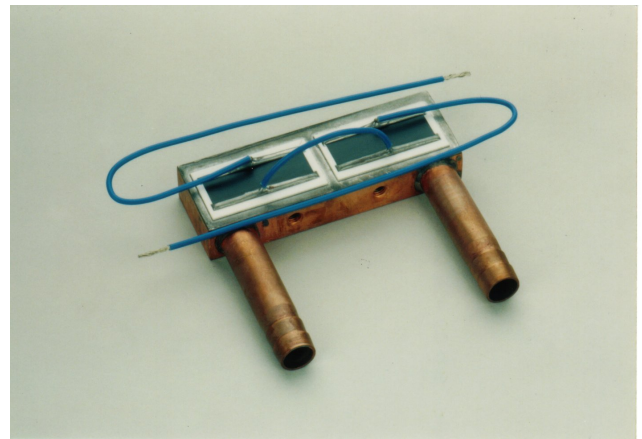

Features and Applications

Small sized 500W water-cooled non-inductive resistor with a very low resistor temperature under operation.

Flat plate resistance and twisted pair leads and special terminal structure (patent) are shown excellent surge absorption performances.

Resistors are insulated from case by the high purity alumina substrate, and are guaranteed to voltage-proof of 5kV.

Leads type, length, terminal processing (patented), and hose connection can be accepted arbitrary demands.

Surge suppression resistors for power thyristor and IGBT, used in power supply of electric power conversion system and of industrial apparatus, high output AC motor controls.

Dimensions (mm)

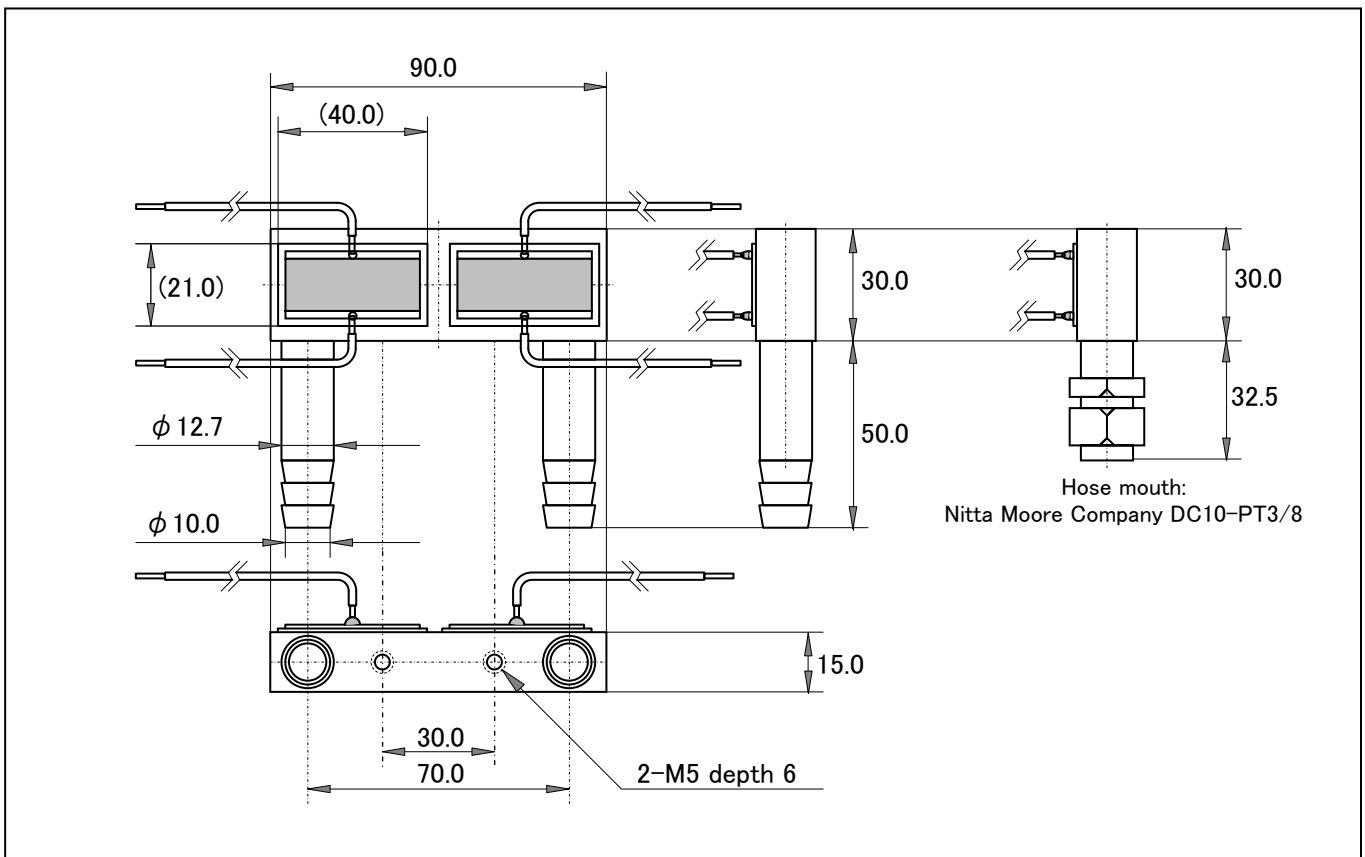

POWER - NIKKOHM

500W WATER COOLING NON-INDUCTIVE HIGH POWER RESISTORS

RPH500

Specifications and Performances

	Specifications
Resistance	Any Value (odd value will be under MOQ 100pcs)
Resistance Range	0.1ohm-1Kohm
TCR	+/-250ppm/ degree C
Tolerance	+/-10%
Series Inductance	40nH/dual resistor, (Typical)
Parallel Capacitance	160pF/dual resistor, (Typical)
Hose Mouth	Standard: Nipple, any types are available.
Water Temperature	+41degreeC maximum at inlet, more than the dew point
Volume of Water Flow	2 liters/minutes minimum.
Water Pressure Loss	0.06Kg/(cm*cm)
Water Temperature Rise	1.4 degree C
Case Temperature Rise	14 degree C
Surface Temperature Rise	50 degree C
Surface Temperature Rise	Maximum 110 degree C
Rating Power	500W (250W/resistor element)
Max. Applied Power	700W (350W/resistor element)
Max. Continuous Impulse Load	Peak Power 37KW/10us/10KHz (Only for reference)
Damaged Impulse Load	100KW peak power/70us single and 37KW peak power/34us continuous.
Terminal Codes	Teflon Insulated Wire(0.18/30, outer diameter 2mm, Blue), 200mm length.
Dielectric Strength	AC2000V, 60 seconds. (Between terminals and case)
Max Operating Voltage	AC1000V
Insulation Resistance	1000Mohmminimum. (Between terminals and case)
Load Life	+/-2% (Rating 500W, 1000 hours)
Humidity	+/-2%(Rating*0.1, 1000hours, continuous load)
Weight	350 grams

Ordering Information

Model	TCR	Resistance	Tolerance	Remarks
RPH500	H	20 Ohm	K	
RPH500-000	H (250ppm/K)	0.1 Ohm-1k Ohm	K (+/-10%)	
RPH500-001				
RPH500-999				

xxx: 3 digits specified code from specification draw, please call factory

Schematics & Wiring

A resistor includes a couple of resistor elements and has following three ways connection. Series connection is standard, but if customer request specified connection and fly-lead length, please call our factory.

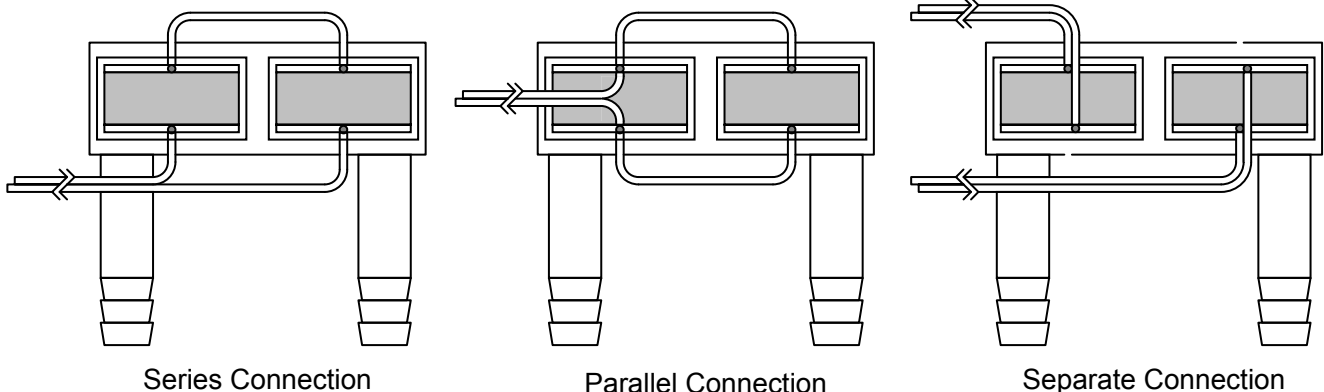

500W WATER COOL NON-INDUCTIVE HIGH POWER RESISTORS

RPH500

Temperature Rise Characteristics

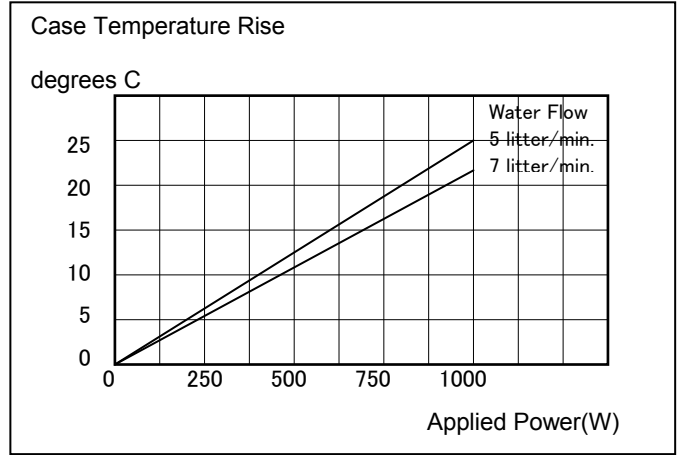
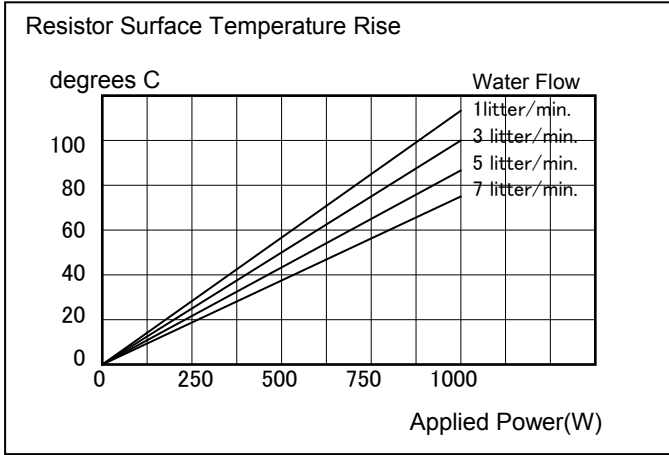

Recommended Long Life Actual Application of RPH500 snubber.

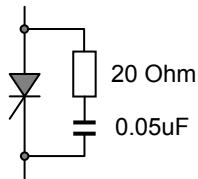
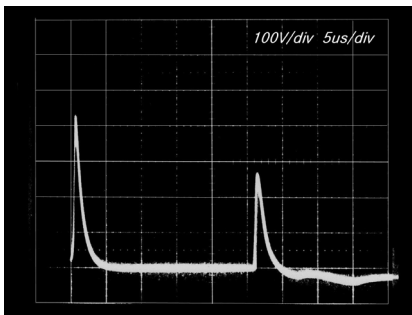

CR snubber for thyristor converter

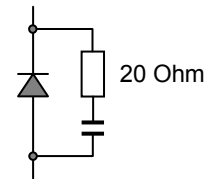
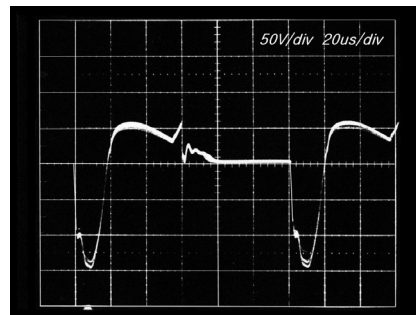

CRD snubber

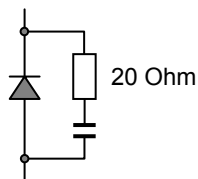
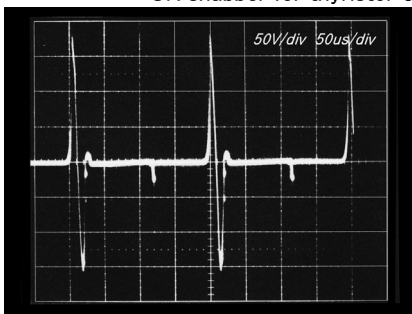

CRD snubber

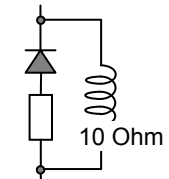
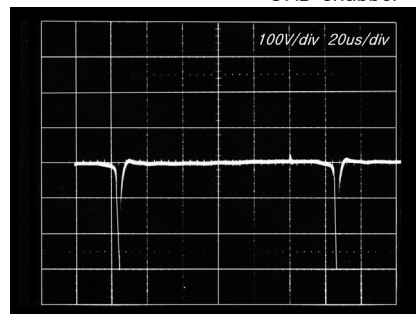

LRD snubber

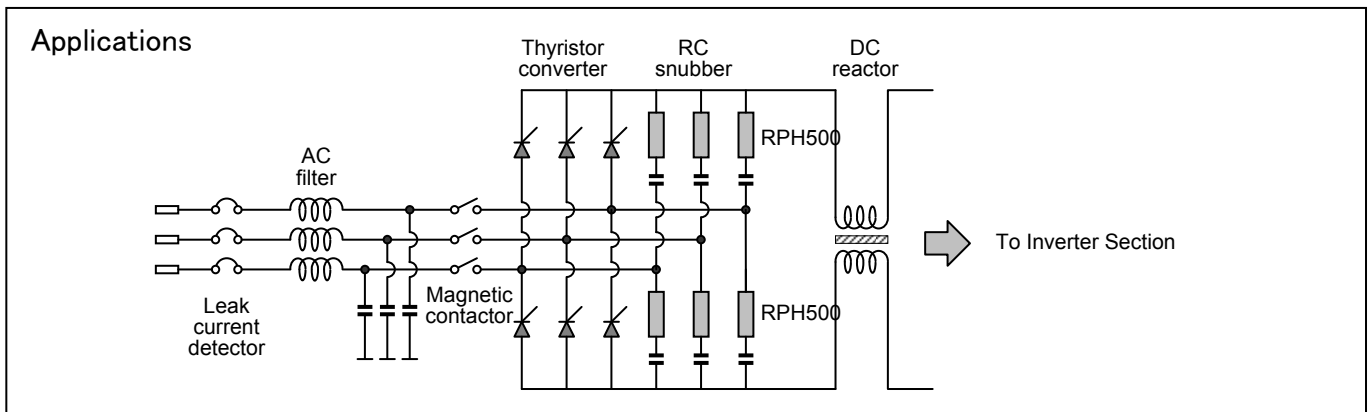

WATER COOLED HIGH POWER RESISTORS
RPH-500, SRPH-1000S, RPH-2000S

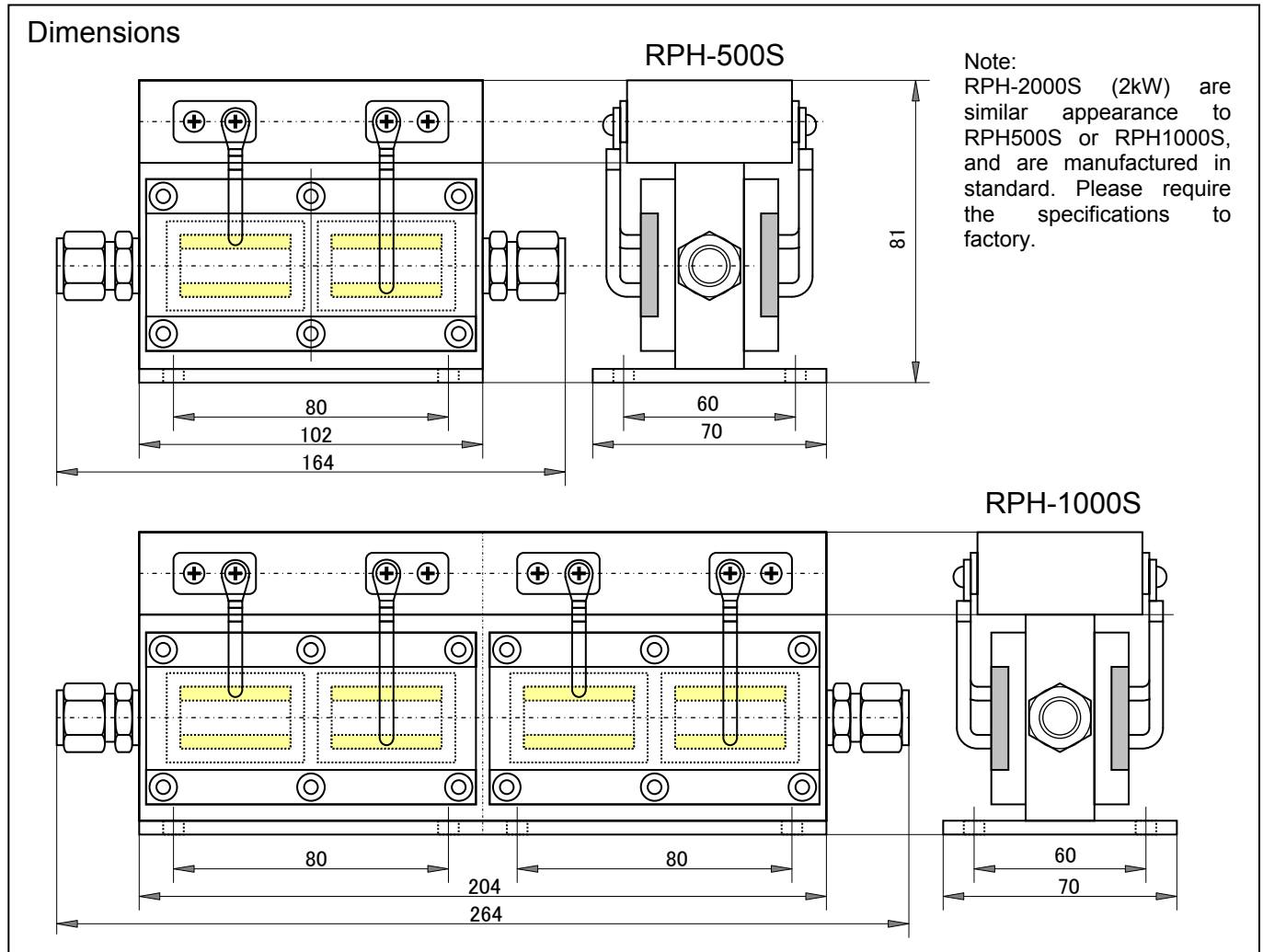

Specifications and Performances

Specification Items	RPH-500S	RPH-1000S	RPH-2000S	Test Conditions
Rating Power	500 W	1KW	2KW	
Resistance Range	0.22ohm~1Kohm			
Nominal Resistance	Any Value			
TCR	±250 ppm/deg C (H)			For -55 to +155 deg C
Tolerance	±10% (K)			
Withstanding Voltage	2000 V AC			Terminals and case
Inductance	0.1μH			
Capacitance	300pF	600pF	1200pF	4.7pF at series connection
Maximum Water Pressure	10kg/cm ²			
Volume of Water Flow	6 liters/min			
Standard Water Temperature	41°C			At inlet
Minimum Water Temperature	Over Dew Point			
Water Temperature Rise	1.4°C	3.0°C	6.0°C	At outlet at rating power
Case Temperature Rise	14.0°C			
Resistor Surface Tem. Rise	50.0°C			At rating power
Maximum Surface Temperature	110°C			At rating power
Pressure Loss	0.1kgf/ cm ²			
Weight	3kg	5kg	10kg	

20100601

表面実装巻線形固定抵抗器

SMD Wire Wound Chip Resistors

S-1, S-2, S-3, S-4, S-5



特長用途

- 表面実装精密巻線抵抗器
- 広域の抵抗値範囲、0.01Ωから51kΩ
- 許容差+/-0.01%まで、TCR20ppm/K
- 最高使用温度 275°C
- 強力なサージ耐性
- 無誘導巻、誘導巻、対応
- 充電機器電流監視、DC/DCコンバータ、DC/ACコンバータ、IPM、ACサーボモータ駆動機器等。

Features and Applications

- Molding SMD precision wire wound chip resistor.
- Wide resistance range of 0.01 to 50kohm..
- Tolerance, to +/-0.01%.
- High temperature rating up to 275 deg C.
- Low temperature coefficient to +/-20ppm/K.
- Superior surge handling capability
- Non-inductive winding are available.
- DC-DC conversion modules, DC-AC conversion, servo-motor control electronics, intelligent power modules and power supplies.

外形寸法

Dimensions

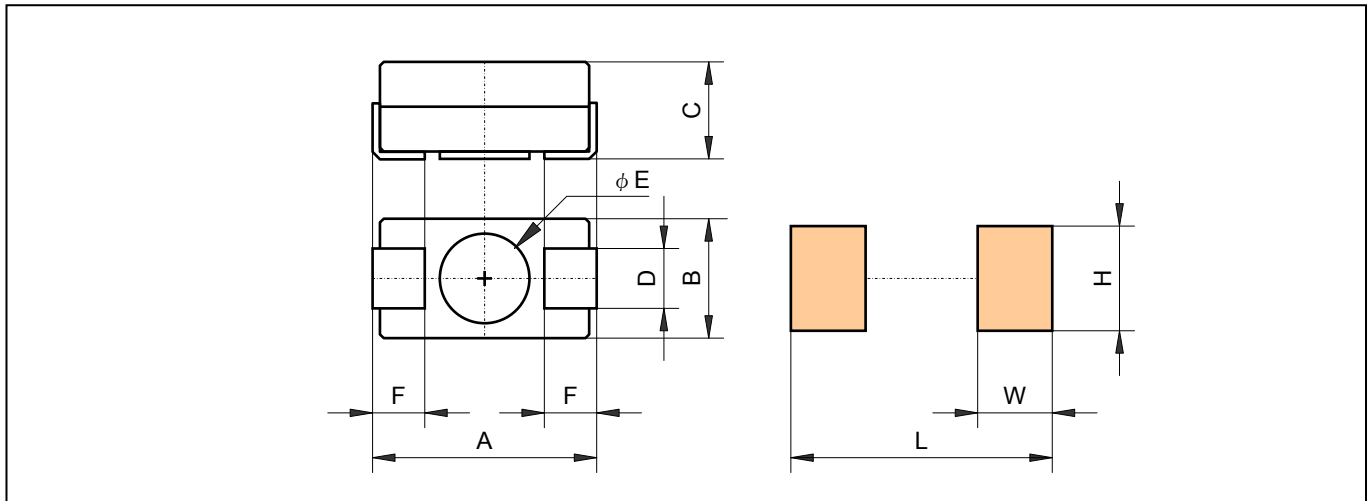

Type	Dimensions						Stand-off		Foot print		
	A +/-0.4mm	B +/-0.4mm	C +/-0.4mm	D +/-0.4mm	F +/-0.4mm	Lead thickness +/-0.05mm	E +/-0.4mm	Height +/-0.15mm	W +/-0.4mm	H +/-0.4mm	L +/-0.4mm
S-1	4.8	3.3	2.8	1.5	1.0	0.15	2.5	0.13	1.6	2.5	6.4
S-2	6.6	3.9	3.2	1.8	1.8	0.15	3.0	0.13	2.4	2.8	8.6
S-4	11.4	6.4	4.6	3.0	2.5	0.16	4.8	0.13	3.9	6.8	13.7
S-3	15.9	6.9	6.4	3.0	3.4	0.15	3.8	0.13	5.1	3.8	17.8
S-5	20.8	7.5	7.7	3.8	4.8	0.15	6.2	0.13	5.6	6.4	22.9

形名称

Ordering Information

S-4	---	100 Ohms	F	Z01	Note
S-1	TCR If not standard	Any value in Resistance range	+/-0.01 (T)	Z01	Tape reel small quantity
S-2			+/-0.05 (A)		
S-4			+/-0.1 (B)		
S-3			+/-1.0 (F)		
S-5			+/-5.0 (J)		

表面実装巻線形固定抵抗器

SMD Wire Wound Chip Resistors

S-1, S-2, S-3, S-4, S-5

仕様 Specifications

Type	Power rating Watts @ 70°C	Resistance Range (Ω)	Maximum Working Voltage
S-1	0.5	0.01 - 400	$\sqrt{P \times R}$ (V)
S-2	1.0	0.005 - 3k	$\sqrt{P \times R}$ (V)
S-4	2.0	0.01 - 15k	$\sqrt{P \times R}$ (V)
S-3	3.0	0.01 - 25k	$\sqrt{P \times R}$ (V)
S-5	4.0	0.01 - 50k	$\sqrt{P \times R}$ (V)

仕様 Specifications

Specifications	Value	Conditions
Tolerances	+/-0.01% - +/-5.0%	---
Temperature Coefficient	>10ohms +/-20ppm/K, 1ohm-10ohm 50ppm/K	---
Temperature Range	-55 deg C - +275 deg C	---
Dielectric Strength	1000VAC	---
Insulation Resistance	> 1Gohms	---
Reel Tape Width (mm)	S1,12mm, S-2,16mm, S-3, 24mm, S-4,24mm, S-5,32mm	---

信頼性 Environmental Performance

Specifications	Value (△Max.)	Conditions
Dielectric	+/-0.5%	MIL-STD-202
Load Life	+/-1.0%	MIL-STD-202
Strage	+/-0.5%	MIL-STD-202
Moisture resistance	+/-1.0%	MIL-STD-202
Thermal Shock	+/-0.5%	MIL-STD-202
5 times 5 seconds Overload	+/-0.5%	MIL-STD-202

負荷軽減曲線

Power Derating

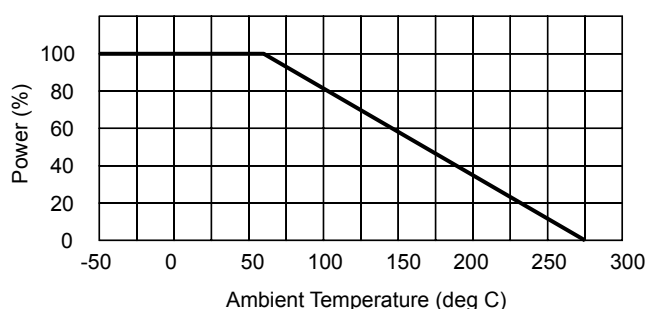

包装仕様

Packaging

	Standard Package Quantities				
	S-1	S-2	S-4	S-3	S-5
Small Reel	650	600	250	125	180
Large Reel	3000	2000	1000	500	500

Note:

耐湿性包装については、この抵抗器は、1年間室内環境保管状態でMSLレベル2です。したがって、吸湿インジケータカードとともに、耐湿性包装(MBB)で包装してあります。また MBB には、MSL の識別表記がされています。

この抵抗器の生産国は、米国です。

Surface mount wire wound resistors have a Moisture Sensitivity Level (MSL) rating of 2 (1 year floor life).

Surface mount parts are packaged in a Moisture Barrier Bag (MBB) with a Humidity Indicator Card and desiccant to monitor and protect the parts from humidity. The MBB is marked with a Moisture Sensitive Identification Label.

20121201

1W - 15W AXIAL LEAD WIRE WOUND RESISTORS

UT-1A, UT-2A, UT-2B, UT-3, UT-5
 UT-6, UT-7A, UT-10, UT-15

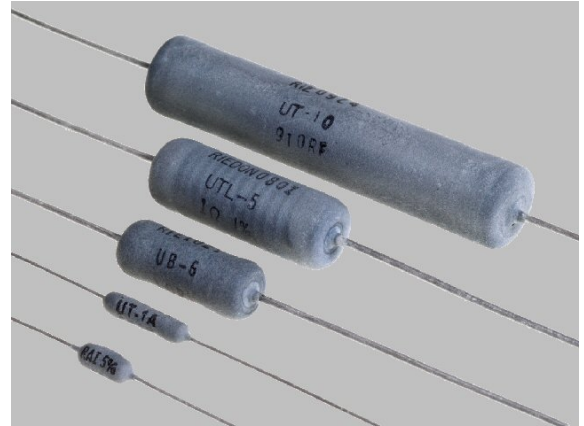

Features and Applications

Precision wire wound resistors from 1W to 15W rated power based on MIL RW-6x and MIL RW-7x. Operating temperature range from -55°C to 275°C (U) – 350°C (V) are performed by using strong silicone resin. Welding structure and high purity ceramic core assures long life stability. Difference with the UB series has a big dimensions than UB, and the rated power is lower and UT is designed the reliable characteristics. Strong over load characteristics are fit for applications of industrial power electronics, industrial measurements, automatic testing, switching power supplies, motor control electronics, inrush current protection in automotive electronics, industrial power supplies.

寸法 Dimensions (mm)

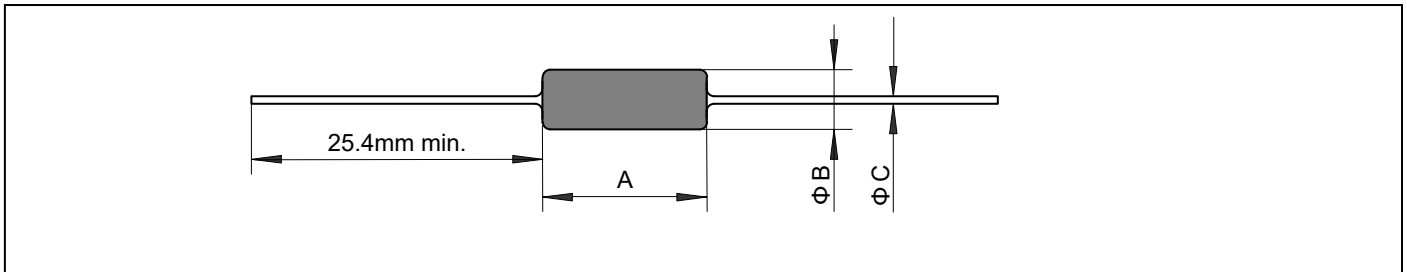

Type	Wattage Rating	Wattage Rating	Dimension A	Dimension B	Dimension C	Maximum Ohms	Maximum Working Voltage	MIL-R-26 MIL-R-39007 Style
	U (W)	V (W)	+/-1.6(mm)	+/-0.8(mm)	+/-0.05(mm)	(Ohms)	(V)	
UT-1A	1.0	1.5	10.3	2.4	0.5	10k	52	RW-70
UT-2A	2.5	3.0	12.7	4.7	0.8	22k	130	RW-69
UT-2B	3.0	3.75	14.2	4.7	0.8	22k	140	RW-79
UT-3	4.0	5.5	17.1	6.9	0.8	45k	210	
UT-5	5.0	6.5	22.2	7.9	1.0	91k	360	RW-74
UT-6	5.0	6.5	25.4	7.9	1.0	95k	504	
UT-7A	7.0	9.0	35.0	9.5	1.0	150k	650	
UT-10	10.0	13.0	45.2	9.5	1.0	260k	850	RW-78
UT-15	15.0	---	46.0	13.0	1.2	320k	1500	

Note1: Ratings are shown at max. ambient temperature of 275°C, (Rating W) shall be used at 350°C maximum temperature. Lead Diameter, 18AWG=0.040", 20AWG=0.032", 22AWG=0.025", 24AWG=0.020", 25AWG=0.018". For non-inductive winding, divide maximum resistance by 2.

1W - 15W AXIAL LEAD WIRE WOUND RESISTORS

UT-1A, UT-2A, UT-2B, UT-3, UT-5, UT-6, UT-7A, UT-10, UT-15

Ordering Information

Type & Rating	-----	Resistance	Tolerance	Packaging	Remarks
UT-2A	-----	10 ohm	F	Z01	
UT-1A	-----	Any value	B(+/-0.1%)	Z00 (1000pcs bulk)	Inductive
UT-2A		0.02 ohm to	F (+/-1.0%)	Z01 (1000pcs tape)	Inductive
UT-2B		Max. value	J(+/-5.0%)		Inductive
UT-3					Inductive
UT-5					Inductive
UT-6					Inductive
UT-7A					Inductive
UT-10					Inductive
UT-15					Inductive
UTN-1A					Non-inductive
UTN-2A					Non-inductive
UTN-2B					Non-inductive
UTN-3					Non-inductive
UTN-5					Non-inductive
UTN-6					Non-inductive
UTN-7A					Non-inductive
UTN-10					Non-inductive
UTN-15					Non-inductive

Specifications

Specifications	Value
Tolerance	+/-0.1%, +/-1.0%, +/-5% (+/-0.01% available)
Temperature Coefficient, over 10ohm	+/-20ppm/K
Temperature Coefficient, 1ohm to 10ohm	+/-50ppm/K
Temperature Coefficient, less than 1ohm	Typical +/-150ppm/K
Temperature Range	-55C to 275°C, characteristic U -55°C to 350°C, characteristic V
Dielectric Strength	500VAC, UT-1, UT-1A, 1000VAC for all others
Environmental Performance, MIL-STD202	Δ R characteristic U
Dielectric	+/-0.2%
Load Life	+/-1.0%
Storage	+/-0.2%
Moisture Resistance	+/-0.2%
Thermal Shock	+/-0.2%
5x Rated Power, 5 seconds Overload	+/-0.2%
Mechanical Shock	+/-0.1%
Vibration	+/-0.1%
	Δ R characteristic V
	+/-0.2%
	+/-3.0%
	+/-2.0%
	+/-2.0%
	+/-2.0%
	+/-0.2%
	+/-0.2%

Derating

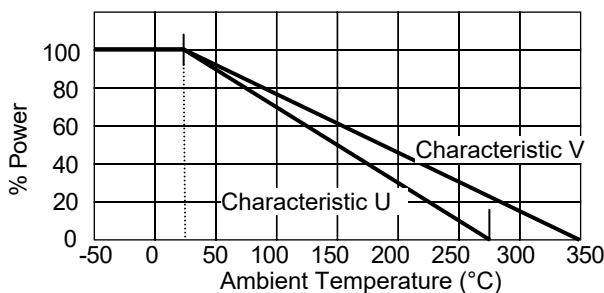

Aluminum Housed Wire Wound Resistors UAL-5, UAL-10, UAL-25, UAL-50



Features and Applications

- Power rating 5W to 50W, when requesting over 50W, please select WD75, WD100, WD150, WD200, WD250, WD300.
- High temperature operation, -55 deg C to 275 deg C
- Rush current protection.
- All welded construction.
- Low TCR 20ppm/K, Tolerance 1% in standard and available up to 0.01%.
- Non-inductive winding is available, called UALN.
- MIL-R-39009 and MIL-R-18546 style.

Dimensions (mm)

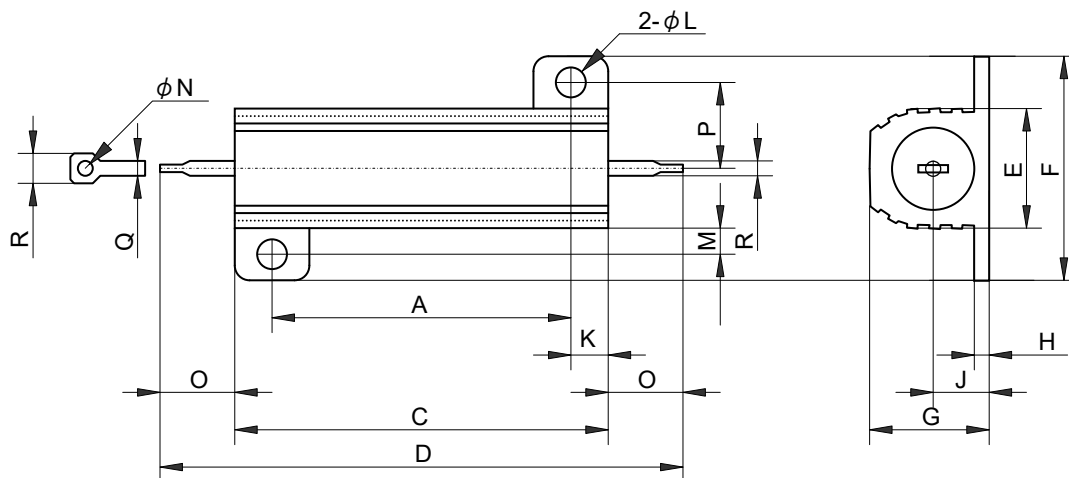

(mm)	A	B	C	D	E	F	G	H	J	K	L	M	N	O	P	Q	R
	±0.13	±0.13	±0.80	±1.60	±0.40	±0.40	±0.40	±0.25	±0.25	±0.25	±0.13±	±0.40	±0.15	±0.80	±0.80	±0.05	±0.80
UAL5	11.3	12.4	15.2	28.5	8.5	16.4	8.1	1.7	3.6	2.0	2.4	2.0	1.3	6.8	6.2	1.30	2.2
UAL-10	14.3	15.9	19.1	33.5	10.9	20.3	10.2	1.9	4.8	2.4	2.4	2.6	2.0	7.9	7.9	2.49	4.0
UAL-25	18.3	19.8	27.0	47.5	13.5	27.4	14.2	2.2	6.6	4.4	3.2	3.2	2.0	11.1	9.9	2.49	4.7
UAL-50	39.7	21.4	50.0	70.0	15.6	29.0	15.6	2.2	7.6	5.0	3.2	3.2	2.0	11.1	10.7	2.49	4.7
UALN-5	11.3	12.4	15.2	28.5	8.5	16.4	8.1	1.7	3.6	2.0	2.4	2.0	1.3	6.8	6.2	1.30	2.2
UALN-10	14.3	15.9	19.1	33.5	10.9	20.3	10.2	1.9	4.8	2.4	2.4	2.6	2.0	7.9	7.9	2.49	4.0
UALN-25	18.3	19.8	27.0	47.5	13.5	27.4	14.2	2.2	6.6	4.4	3.2	3.2	2.0	11.1	9.9	2.49	4.7
UALN-50	39.7	21.4	50.0	70.0	15.6	29.0	15.6	2.2	7.6	5.0	3.2	3.2	2.0	11.1	10.7	2.49	4.7

Aluminum Housed Wire Wound Resistors
UAL-5, UAL-10, UAL-25, UAL-50

Power Rating and Resistance

Model	Style	Power Rating(W @ 25°C)			Resistance Range (ohm)
	MIL-R-39009 MIL-R-18548	Commercial	MIL	Free Air	
UAL-5	PER-60 / RE-60	7.5 (1)	5 (1)	4.5	0.01 – 22K
UAL-10	PER-65 / RE-65	12.5 (1)	10 (1)	7.5	0.005 – 10K
UAL-25	PER-70 / RE-70	25 (2)	20 (2)	12	0.005 – 36K
UAL-50	PER-75 / RE-75	50 (3)	30 (3)	20	0.01 – 86K

Note:

For non-inductive windings, divide maximum resistance by 2.

- (1) Heat-sink required 1.0mm Aluminum plate of 832 cm² or equivalent.
- (2) Heat-sink required 1.0mm Aluminum plate of 1077 cm² or equivalent.
- (3) Heat-sink required 1.5mm Aluminum plate of 1877 cm² or equivalent.

Ordering Information

Model	Resistance	Tolerance	Note
UAL-25	50ohm	1%, F	1%, standard
UAL-5	any value in above range	0.05%, A	Inductive winding
UAL-10		0.10%, B	Inductive winding
UAL-25		0.25%, C	Inductive winding
UAL-50		0.50%, D	Inductive winding
		1.00%, F	
UALN-5			Non inductive winding
UALN-10			Non inductive winding
UALN-25			Non inductive winding
UALN-50			Non inductive winding

For non-inductive windings, please attach 'N' after 'UAL' as 'UALN'

Specifications

Specifications	Specifications
Tolerance	0.05%, 0.10%, 0.25%, 0.5%, 1%
TCR over 10ohm	+/-20ppm/K
TCR 1ohm to 10ohm	+/-50ppm/K
TCR less than 1ohm	Call factory
Temperature Range	-55 deg C to 275 deg C
Dielectric Strength	1500VAC
Environmental Performance, MIL-STD202	ΔIR
Dielectric	+/-0.2%
Load Life	+/-1.0%
Storage	+/-0.2%
Moisture Resistance	+/-0.2%
Thermal Shock	+/-0.2%
5X – 5 seconds Overload	+/-0.2%
Mechanical Shock	+/-0.1%
Vibration	+/-0.1%

Note: Country origin of UAL series is U. S. A.

Minimum order quantity is 100pcs in UAL-5, UAL10, UAL-25 and UAL-50.

Derating

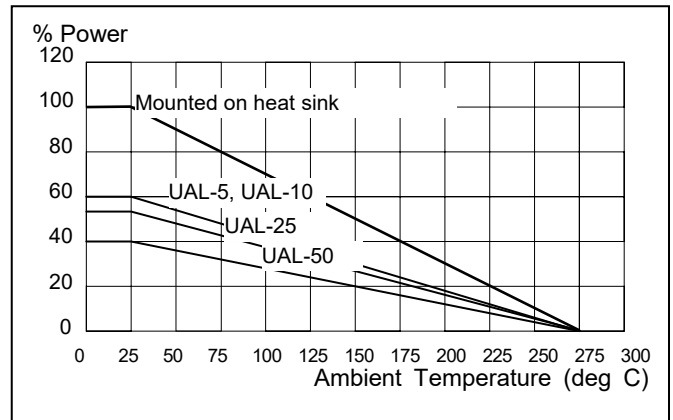

Aluminum Housed Wire Wound Resistors WD75, WD100, WD150, WD200, WD250, WD300

Features and Applications

- Power rating 75W to 300W
- High temperature operation, -25 °C to 250 °C
- Rush current protection.
- All welded construction.
- Low TCR 30ppm/K, Tolerance 5% in standard and available up to 0.25%.
- Non-inductive winding is available, called WDN.
- MIL-R-39009 and MIL-R-18546 style.
- Applications include converter / inverters for power electronics



Dimensions (mm)

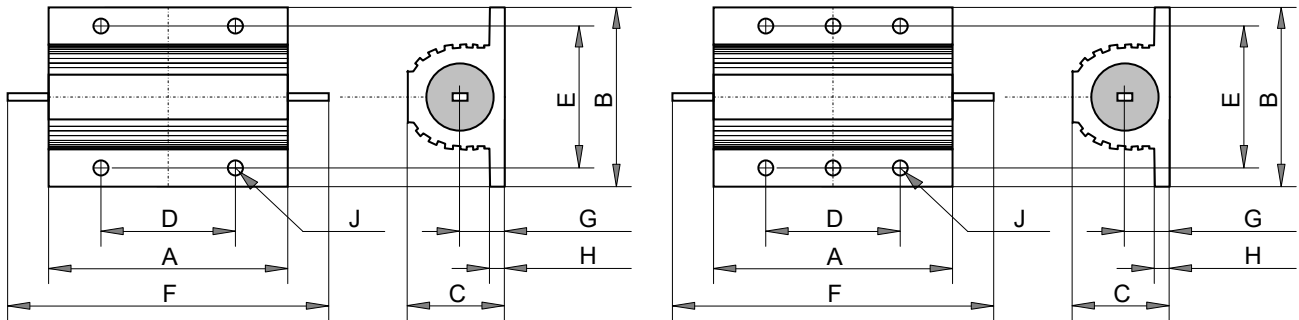

(mm)	A	B	C	D	E	F	G	H	J
	±0.5	-	Max	±0.3	±0.3	Max	Max	-	±0.5
WD75	48.9	48.0	26.0	29.0	37.0	71.0	12.0	4.0	4.4
WD100	65.4	48.0	26.0	35.0	37.0	87.5	12.0	4.0	4.4
WD150	97.0	48.0	26.0	29.0+29.0	37.0	122.0	12.0	4.0	4.4

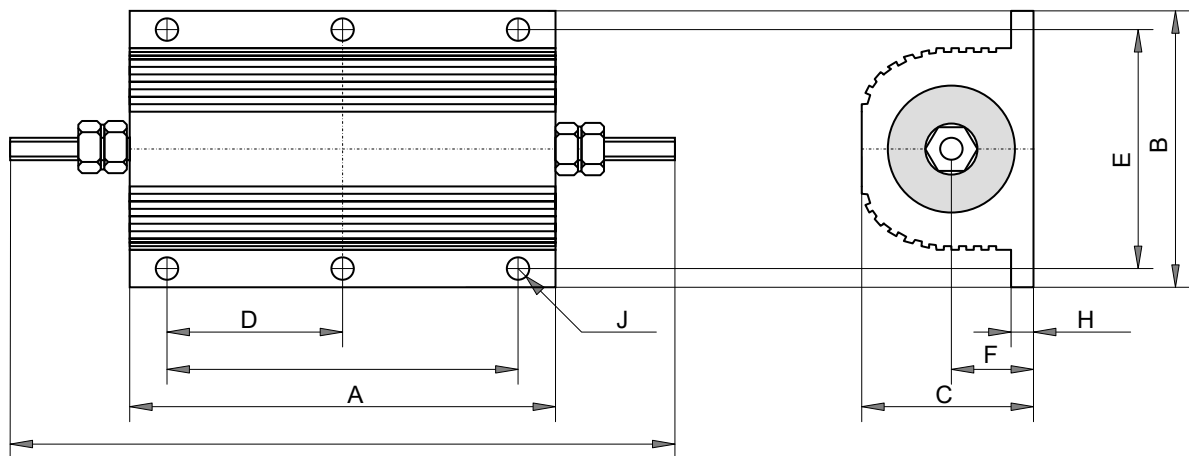

(mm)	A	B	C	D	E	F	G	H	J
	±0.3	-	max	±0.3	±0.3	max	max	-	±0.5
WD200	89.0	73.0	45.0	35.0	57.2	20.5	143.0	5.5	5.1
WD250	114.0	73.0	45.0	44.5	57.2	20.5	163.0	5.5	5.1
WD300	127.0	73.0	45.0	52.0	59.0	20.5	180.0	5.5	6.6

Aluminum Housed Wire Wound Resistors
 WD75, WD100, WD150, WD200, WD250, WD300

Power Rating and Resistance

Model	Power Rating(W @ 25°C)		Resistance Range (Ω)	Max. Application Voltage (V)	Dielectric Strength	Weight (g)
	With heat sink	Without heat sink				
WD75	75	45	0.01 – 50K	1400	5 kV AC	85
WD100	100	50	0.01 – 100K	1900	5 kV AC	115
WD150	150	55	0.01 – 100K	2500	5 kV AC	175
WD200	200	50	0.01 – 50K	1900	5 kV AC	475
WD250	250	60	0.01 - 65K	2200	5 kV AC	600
WD300	300	75	0.01 - 80K	2500	5 kV AC	700

Ordering Information

Model WD75	Resistance Value 50ohm	Tolerance 5% / J	Code Z00
WD75	any value in above range	0.25%, C	Z: RoHS
WD100		0.50%, D	
WD150		1.00%, F	
WD200		5%, J standard	
WD250			
WD300			
WDN75			
WDN100			
WDN150			
WDN200			
WDN250			
WDN300			

For non-inductive windings, please attach 'N' after 'WD' as 'WDN'

Derating

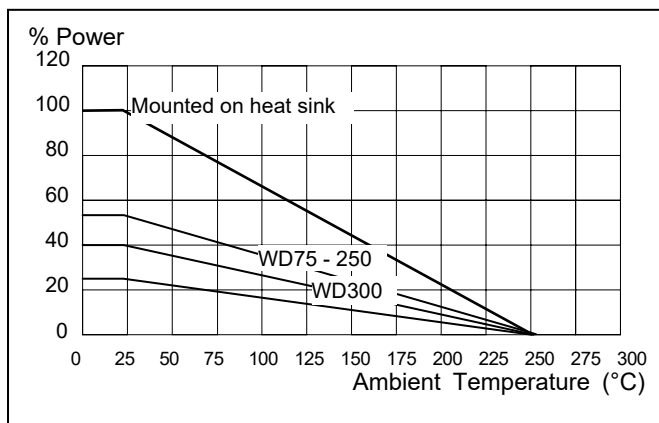

Heat sink, recommended

	Area (cm ²)	Thickness (mm)
WD75	1000	3
WD100	1000	3
WD150	1000	3
WD200	3750	3
WD250	4800	3
WD300	5800	3

Specifications and Performances

	Specifications	Conditions
Tolerance	+/-5%	for values less than 1Ω
	+/-0.25% to +/-5%	for values greater than 1Ω
TCR	60ppm/°C	for values less than 100Ω
	30ppm/°C	for values greater than 100Ω
Temperature Range	-25 °C to 250 °C	
Short time overload	+/-0.5%	10 x rated voltage for 5sec
Shelf life stability	< +/-1%	after 3 years
Incombustibility	No flame	16 x rated wattage for 5sec
Insulation resistance	10G Ω	Dry / Normal

20W, 50W Wire Wound Resistors

RH25C, RH25CN, RH50C, RH50CN



Features and Applications

Inductive (RH25C, RH50C), non-inductive (RH25CN, RH50CN) aluminum clad housed wire-wound resistors. Cement molded resistors construction gives complete environmental protection and 250 deg C high temperature operation.

Complete welding terminal construction.

Braking resistor and dumping resistor of the motor control, rush current protection, gate resistor, snubber resistor.

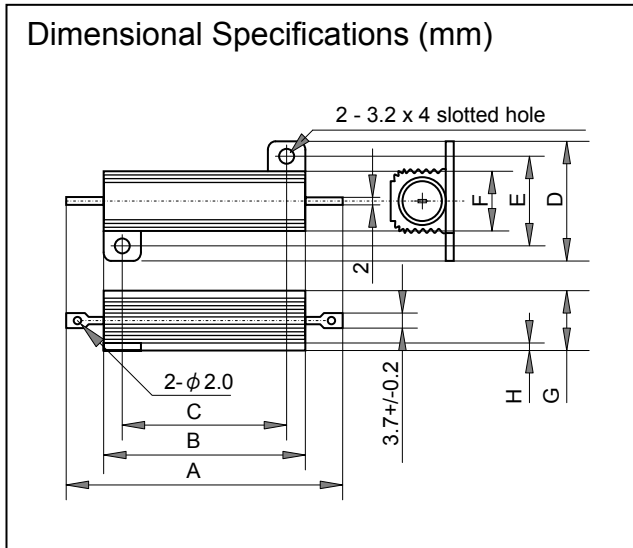

Symbol	RH25C, RH25CN	RH50C, RH50CN
A	49.4±0.2	70.6±0.2
B	27.1+0.15-0.10	49.3+0.15-0.10
C	18.3±0.2	39.7±0.2
D	29.6±0.2	29.6±0.2
E	20.6±0.2	20.6±0.2
F	15.6±0.2	15.6±0.2
G	16±0.2	16±0.2
H	2.2±0.2	2.2±0.2
Weight	16.5gr	35gr

	Specifications	Test Condition
Short time overload	±0.5%	
Heat shock	±0.5%	
Dielectric strength	±0.2%	2000VAC, 60sec.
Insulation resistance	10Gohm	
Load life	±1.0%	
Operating temp. range	-55 to +250 deg C	
Storage temp. range	-55 to +250 deg C	

Specifications

Type	Rated Watt Heat Sink (W)	Rated Watt Free Air (W)	Resistance (ohm)	TC Lower Limit (±ppm/K)				Tolerance (%)
				200ppm	100ppm	50ppm	30ppm	
RH25C	20	8	0.022-25K	0.022-0.09	0.1-0.976	1-19.6	20-25K	±0.1(B),
RH25CN	20	8	0.1-10K	-	0.1-0.976	1-19.6	20-10K	±0.5(D),
RH50C	30, 50(1)	10	0.048-50K	0.048-0.09	0.1-0.976	1-19.6	20-50K	±1.0(F)
RH50CN	30, 50(1)	10	0.2-20K	-	0.2-0.976	1-19.6	20-20K	±5.0(J)

(1) Please see note (1) in next page.

Ordering Information

Model RH25	Filling C	Inductive / not N	Resistance 50ohm	Tolerance F	Note
RH25	C (high temp.)	- (inductive)	any value	B (+/-0.1%)	
RH50		N (non inductive)	in above range	D (+/-0.5%)	
				F (+/-1.0%)	
				J (+/-5.0%)	

20W, 50W Wire Wound Resistors

RH25C, RH25CN, RH50C, RH50CN

Temperature Rise, RH25C

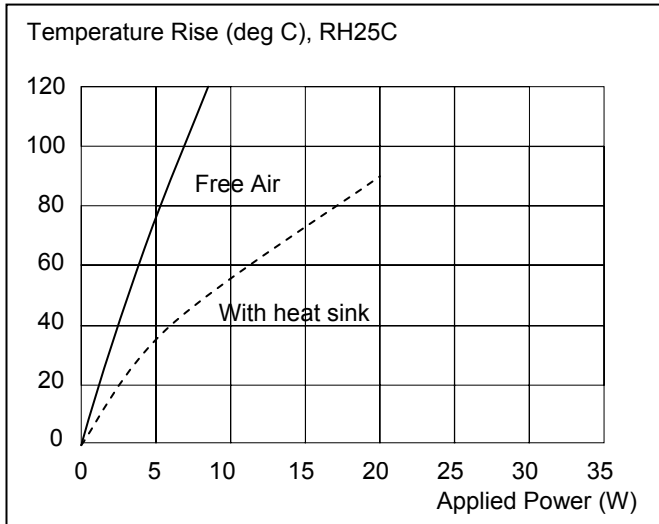

Temperature Rise, RH50C

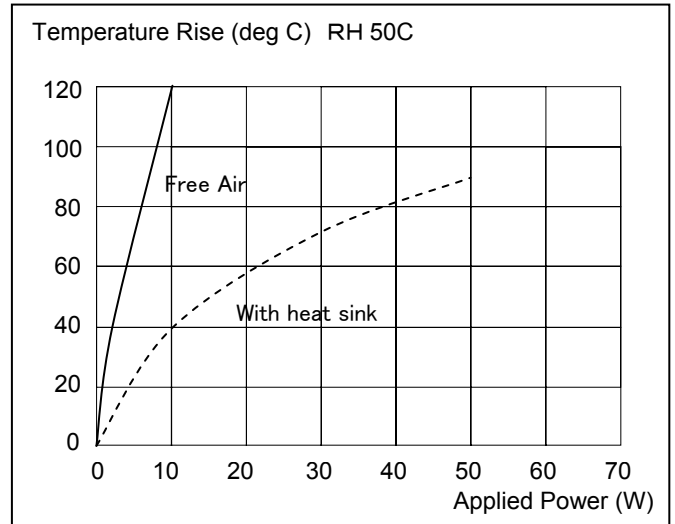

Derating. RH25C

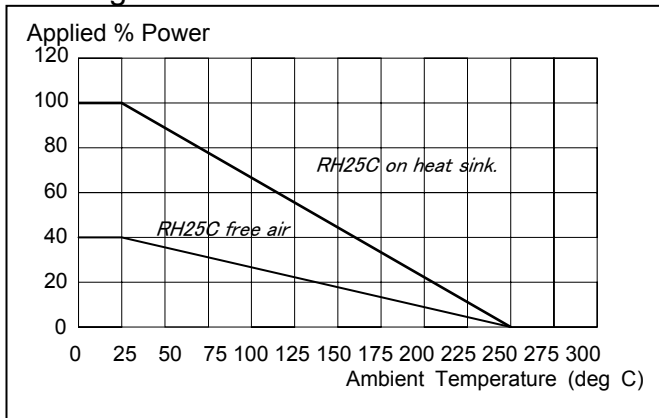

Derating. RH50C

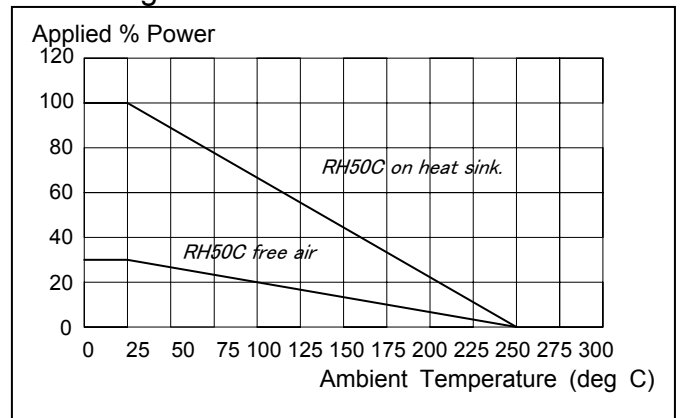

Frequency Characteristics. RH50C and RH50CN

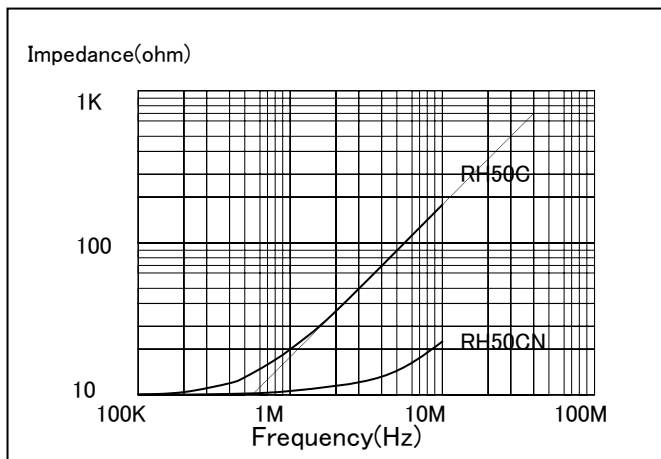

Note:

- (1) 30W rating power of RH50C is on heat sink (178x127x51x1mm), 50W power of RH50C is on heat sink (305x305x2mm)
- (2) RH20 and RH50 were discontinued by reason of increasing high temperature performance, and replace to RH25C and RH50C.

Metal-Clad Wire Wound Resistors ULN, ULF, IRN, IRF

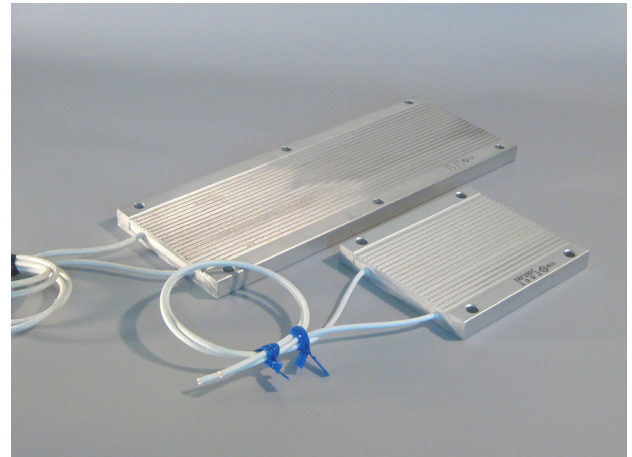

Features and Applications

Flat and slim, 10mm height, light weighted metal clad wire wound power resistor with fly lead terminals. Flat chassis-mount style for 50W to 500W rated power has good heat conducting performance and excellent space factor for installation. Strong and stable resistance wire endures short time overload in power electronics. Applications for rush current protections, braking resistors in motor control, dumping resistor for inductive circuit.

Dimensional Specifications (mm)

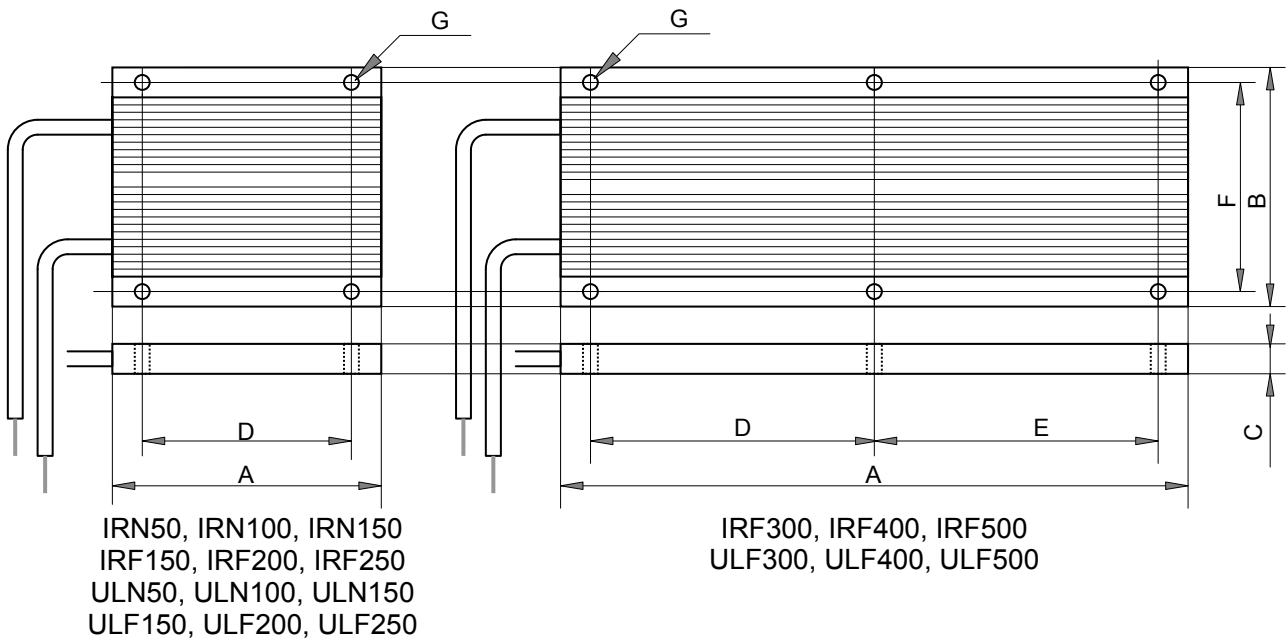

(mm)	IRN50 ULN50	IRN100 ULN100	IRN150 ULN150	IRF100 ULF100	IRF150 ULF150	IRF200 ULF200	IRF250 ULF250	IRF300 ULF300	IRF400 ULF400	IRF500 ULF500
A±1.0	70	120	170	90	120	150	180	210	270	330
B±0.3	60	60	60	80	80	80	80	80	80	80
C	10	10	10	10	10	10	10	10	10	10
D±0.3	50	100	150	70	100	130	160	95	125	155
E±0.3	-	-	-	-	-	-	-	95	125	155
F±0.3	50	50	50	70	70	70	70	70	70	70
G	4-φ5.3	4-φ5.3	4-φ5.3	4-φ5.3	4-φ5.3	4-φ5.3	4-φ5.3	6-φ5.3	6-φ5.3	4-φ5.3
Weight (grams)	100	160	220	155	200	245	290	335	430	525

Metal-Clad Wire Wound Resistors

ULN, ULF, IRN, IRF

Ordering Information

Type	Rated Power	Filling	Resistance	Tolerance	Insulation Volt	Wire Length
ULF	500	S	1R0	5%	4500V	FL300mm
ULN	50, 100, 150	S	1 ohm	0.5%	1000V	Any value
ULF	100	S(silicone)	See spec.	1.0%	1500V	
IRN	150	only		2.0%	2500V	
IRF	200			5.0%	3000V	
	250				4500V	
	300					
	400					
	500					

Specifications and Performances

UL certified	ULN50	ULN100	ULN150	ULF100	ULF150	ULF200	ULF250	ULF300	ULF400	ULF500
Standard	IRN50	IRN100	IRN150	IRF100	IRF150	IRF200	IRF250	IRF300	IRF400	IRF500
Rating Power(W)	50	100	150	100	150	200	250	300	400	500
Free Rating Power(W)	50	90	112	90	112	140	162	195	240	250
Resistance(ohm)	1-420	1-1.1K	1-1.75K	1-1.1K	1-1.75K	1-2.2K	1-2.97K	1-3.5K	1-3.08K	1-2.46K
TCR	±260ppm/°C(H)									
Tolerance (%)	±0.5%(D), ±1.0%(F), ±2.0%(G), ±5.0%(J), ±10%(K)									
Dielectric Strength	AC1000V (AC1500V, AC2500V, AC3000V, AC4500V are available), at leakage current 2mA.									
Temperature Range	-55 deg C to +200 deg C at Cement filled. (-55 deg C to +150 deg C at Silicone filled)									
Insulation Resistance	< 20MΩ									
Short Time Over Load	±1%, (Rating power×10 in 5 seconds interval) (IRN50, Rating power×5 in 5 seconds interval)									
Humidity	±1%,									
Thermal Shock	±1%, (After power with rating for 30 minutes, -15 deg C, 15 minutes)									
Vibration	±1%, (10Hz-55Hz-10Hz, 1minute cycle, for 2 hours with x-y direction)									
Humidity	±1%, (40 deg C, 95%-RH, 0.1*power rating, 1.5hours on 0.5hours off, 500hours)									
Load Life	±1%, (Power rating, 1.5hours on 0.5hours off, 500hours)									
Filling	Silicone only									
Terminals	1.25mm ² (except below resistance) 2.0mm ² (IRF200-1-4ohm, IRF250-1-5ohm, IRF300-1-6ohm, IRF400-1-8ohm, IRF500-1-10ohm)									

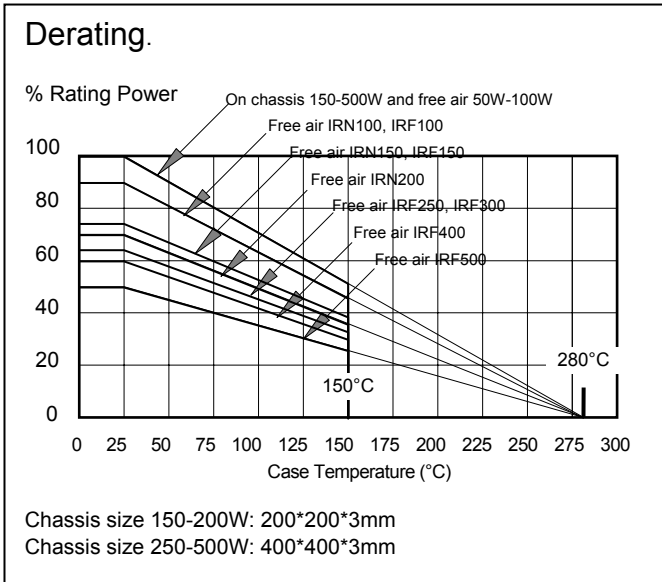

Note: Thickness of the aluminum case of a resistor is 3mm, and since the crevice between the portions filled up with the internal resistance object is 4mm, please do not do make hole processing to the central part of a case main part.

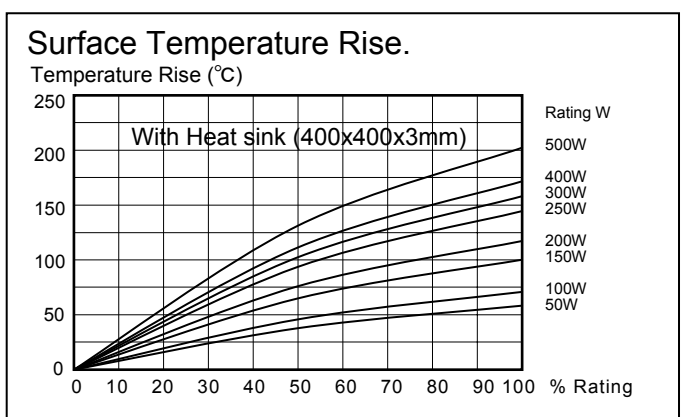
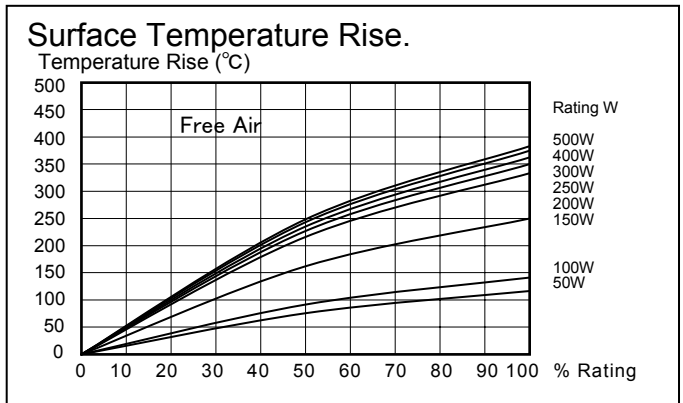

Metal-Clad Wire Wound Resistors

ULN, ULF, IRN, IRF

Typical Absorbed Energy Datasheet of 800 deg C
at pulse width = 0.1 seconds, IRN50

Resistance[Ω]	0.3	0.33	0.36	0.49	0.54	0.61	0.69	0.79	0.89	0.98	1.09	1.24	1.42
Energy[J]	797	718	634	731	662	603	533	460	589	534	478	425	368
Resistance[Ω]	1.58	1.77	3.27	3.64	4.12	4.74	5.27	5.93	6.77	7.29	8.24	9.48	10.53
Energy[J]	331	294	445	399	353	307	276	245	215	199	176	153	138
Resistance[Ω]	11.84	12.64	14.08	14.73	23.74	25.47	28.64	30.82	34.86	37.83	42.9	46.86	53.56
Energy[J]	122	436	400	373	296	276	269	249	240	221	211	193	184
Resistance[Ω]	63.57	70.43	83.95	97.39	113.41	137.11	162.16	204.15	252.12	329.89	426.53	---	---
Energy[J]	179	161	155	143	131	122	110	103	92	85	75	---	---

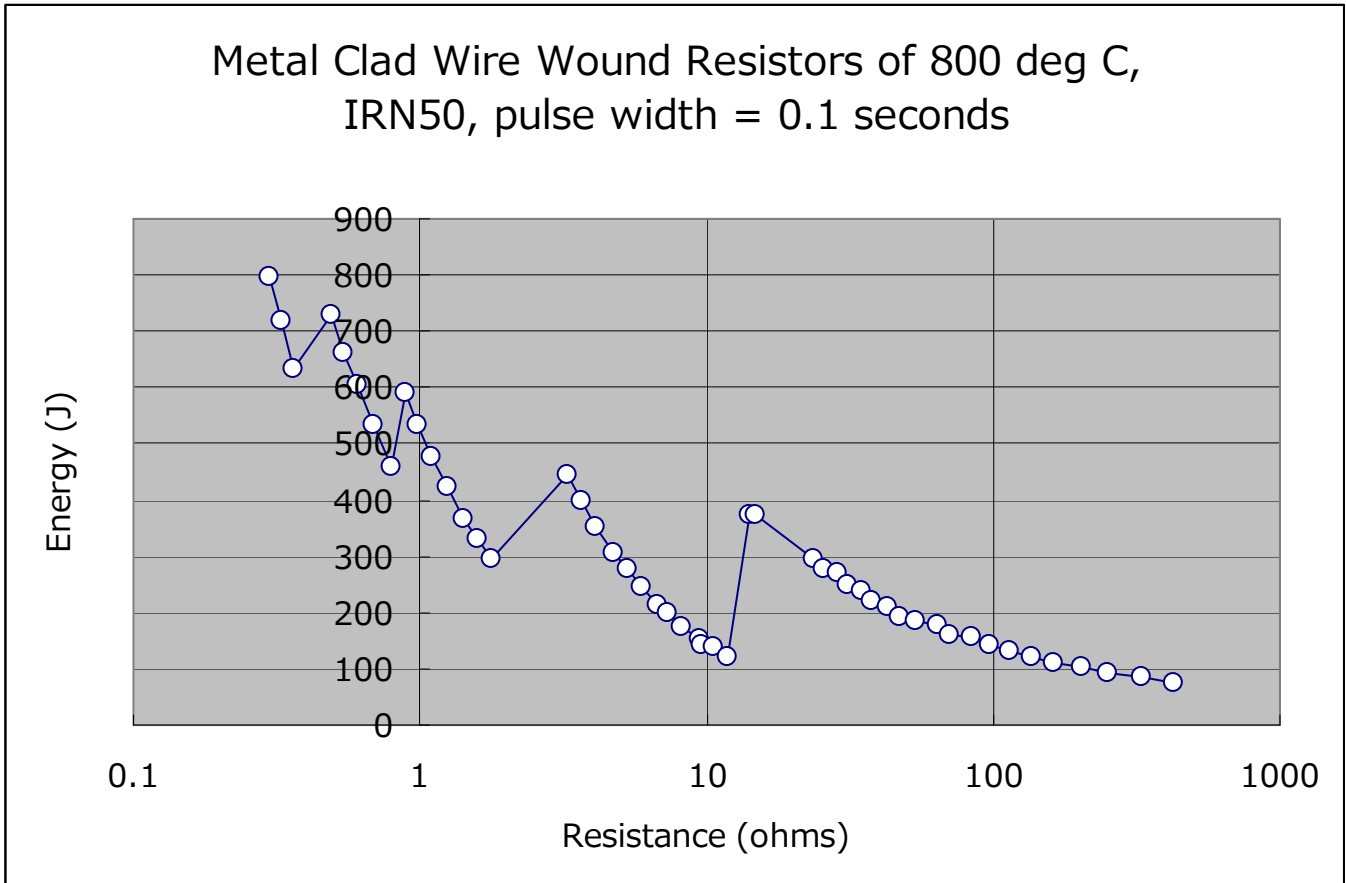

Note: The diameter of resistance wire varies according to a resistance, and the thermal capacity of resistance wire changes. When thermal capacity of the wire increases, the pulse energy durability shows a tendency to increase. Since we provide another resistors of the IRN-IRF series as well as IRN50, please call factory.

Metal Clad Wire Wound Resistors IRV, IRH, ULV, ULH

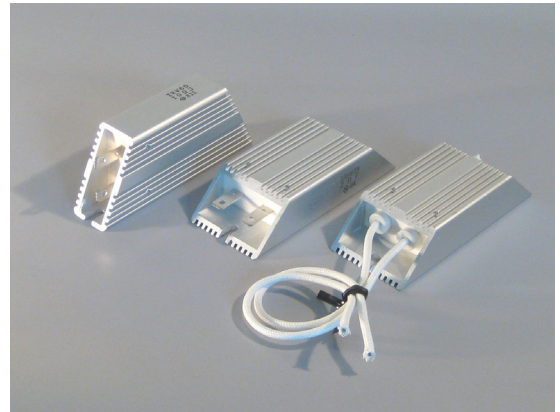

Features and Applications

- Overload durable, metal clad wire wound power resistor.
- 60W to 500W rating power, heat conductive cement filled, aluminum housed resistors.
- Flying leads, metal tab and L type metal tab terminals are available.
- Dielectric strength of 1500V to 5400V available.
- Surge protection resistors, recycling resistors, braking resistors for motor control, and current detection resistors for power electronics.

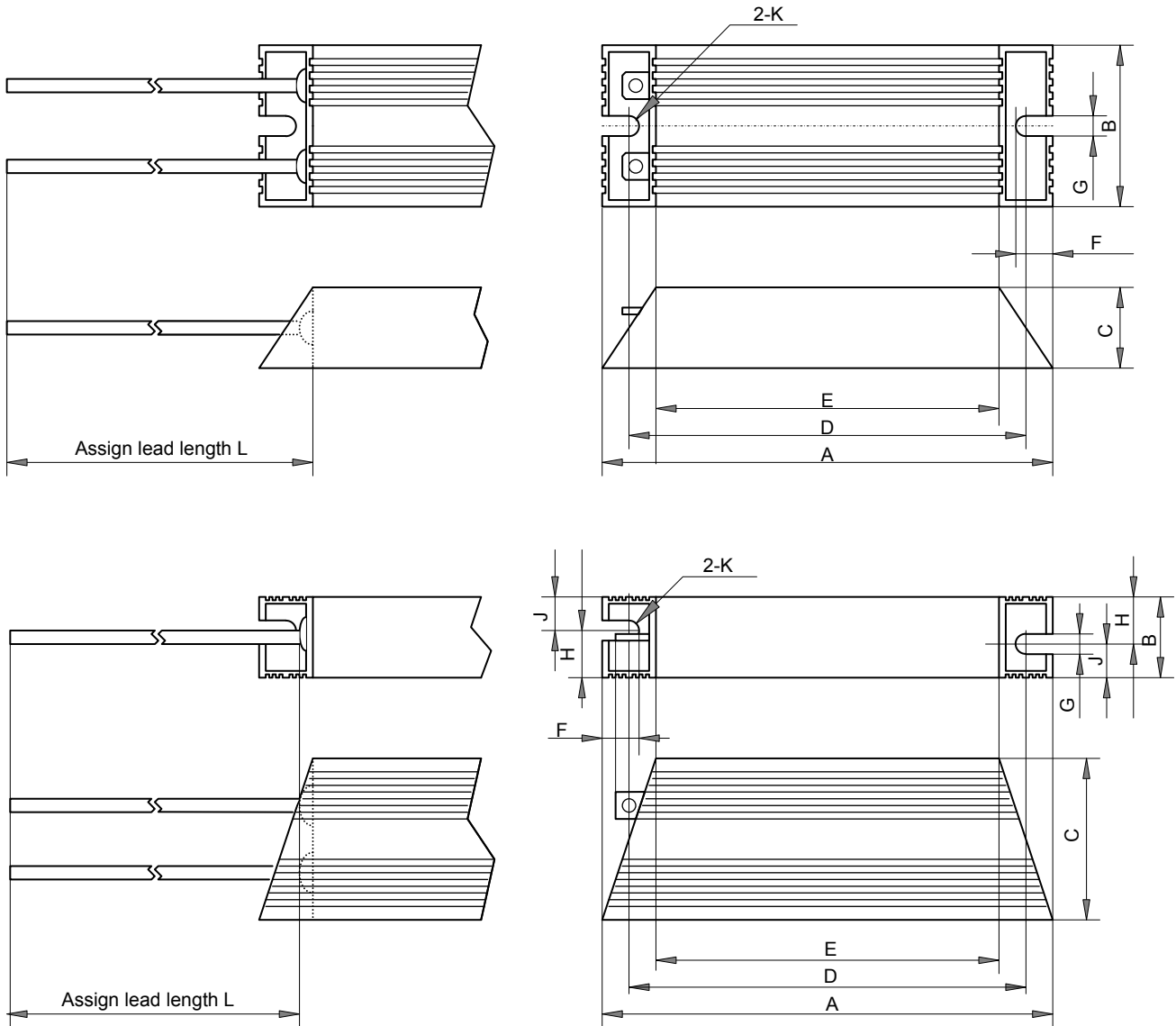

Metal Clad Wire Wound Resistors

IRV, IRH, ULV, ULH

Dimensional Specifications (mm)

	IRV60	IRV80	IRV100	IRV120	IRV150	IRV200	IRV300	IRV400	IRV500
A±2	100	150	165	182	210	165	215	265	335
B±0.5	22	22	22	22	22	30	30	30	30
C±0.5	41	41	41	41	41	60	60	60	60
D±2	87	137	152	169	197	146	196	246	316
E±2	60	110	125	143	170	125	175	225	295
F±0.5	8.65	8.65	8.65	8.65	8.65	12	12	12	12
G±0.5	4.3	4.3	4.3	4.3	4.3	5.3	5.3	5.3	5.3
H	12	12	12	12	12	17	17	17	17
J	10	10	10	10	10	13	13	13	13
K	2.15R	2.15R	2.15R	2.15R	2.15R	2.65R	2.65R	2.65R	2.65R
Weight (g)*	113	189	215	241	290	447	600	780	980

	IRH60	IRH80	IRH100	IRH120	IRH150	IRH200	IRH300	IRH400	IRH500
A±2	100	150	165	182	210	165	215	265	335
B±0.5	41	41	41	41	41	60	60	60	60
C±0.5	22	22	22	22	22	30	30	30	30
D±2	87	137	152	169	197	146	196	246	316
E±2	60	110	125	143	170	125	175	225	295
F±0.5	8.65	8.65	8.65	8.65	8.65	12	12	12	12
G±0.5	4.3	4.3	4.3	4.3	4.3	5.3	5.3	5.3	5.3
H	-	-	-	-	-	-	-	-	-
J	-	-	-	-	-	-	-	-	-
K	2.15R	2.15R	2.15R	2.15R	2.15R	2.65R	2.65R	2.65R	2.65R
Weight (g)*	110	195	216	245	283	485	600	770	990

* Weight does not contains flying wire lead.

Power, Resistance, Terminals

	IRV60	IRV80	IRV100	IRV120	IRV150	IRV200	IRV300	IRV400	IRV500
	IRH60	IRH80	IRH100	IRH120	IRH150	IRH200	IRH300	IRH400	IRH500
Rating Power(W)/Chassis	60	80	100	120	150	200	300	400	500
Rating Power(W)/Free Air	48	64	80	96	120	140	210	240	300
Resistance(ohm) inductive	0.1-400	0.1-910	0.1-1.1K	0.1-1.3K	0.1-1.6K	0.1-2.2K	0.1-2.7K	0.1-4.3K	0.1-6.8K
Resistance(ohm) no-induct.	0.1-180	0.1-110	0.1-240	0.1-300	0.1-390	0.1-1.0K	0.1-1.5K	0.1-2.2K	0.1-3.0K
Tolerance (%)	+/-0.5%(D), +/-1.0%(F), +/-2.0%(G), +/-5.0%(J), +/-10%(K)								
Terminal Wire of 1.25 mm ²	>1.0 ohms					NA	NA	NA	NA
Terminal Wire of 2 mm ²	0.1-0.99 ohms					> 5.0 ohms			
Terminal Wire of 5.5 mm ²	NA	NA	NA	NA	NA	1-4.99 ohms			
Terminal Wire of 8 mm ²	NA	NA	NA	NA	NA	0.1-0.99 ohms			
Tab Terminals #250*2	AB	AB	AB	AB	AB	NA	NA	NA	NA
Metal Terminals 2t-10w-4.3φ	NA	NA	NA	NA	NA	AB	AB	AB	AB
L-Type Metal Terminals	NA								

* AB: available, NA: not available

Power, Resistance, Terminals (UL)

	ULV60	ULV80	ULV100	ULV120	ULV150	ULV200	ULV300	ULV400	ULV500
	ULH60	ULH80	ULH100	ULH120	ULH150	ULH200	ULH300	ULH400	ULH500
Rating Power(W)/Chassis	60	80	100	120	150	200	300	400	500
Rating Power(W)/Free Air	48	64	80	96	120	140	210	240	300
Resistance(tab) inductive	0.1-375	0.1-281	0.1-225	0.1-187	0.1-150	0.1-450	0.1-300	0.1-225	0.1-180
Resistance(tab) no-induct.	0.1-180	0.1-110	0.1-225	0.1-187	0.1-150	0.1-450	0.1-300	0.1-225	0.1-180
Resistance(fly) inductive	0.1-400	0.1-910	0.1-1.1K	0.1-1.3K	0.1-1.6K	0.1-2.2K	0.1-2.7K	0.1-4.3K	0.1-6.8K
Resistance(fly) no-induct.	0.1-180	0.1-110	0.1-240	0.1-300	0.1-390	0.1-1.0K	0.1-1.5K	0.1-2.2K	0.1-3.0K
Tolerance (%)	+/-2.0%(G), +/-5.0%(J), +/-10%(K)								

Specifications and Performance

TCR(ppm/K)	±260ppm/K(H)
Tolerance (%), not UL	±0.5%(D), ±1.0%(F), ±2.0%(G), ±5.0%(J), ±10%(K)
Dielectric Strength	AC1500V, AC2500V, AC3000V, AC4500V and AC5400V are available at leakage current 2mA.
Temperature Range	-55 C to +200 C
Insulation Resistance	< 20Mohms
Short Time Over Load	±2%, (Rating power×10 in 5 seconds interval) (IRH/V60, Rating power×5 in 5 seconds interval)
Moisture Resistance	±3%, (40C,95%RH, DC100V case / terminal, 500hours)
Thermal Shock(%-ohms)	±2%, (After power with rating for 30 minutes, -15C, 15 minutes)
Vibration(%-ohms)	±1%, (10Hz-55Hz-10Hz, 1minute cycle, for 2 hours with x-y direction)
Humidity(%-ohms)	±3%, (40C,95%-RH, 0.1*power rating , 1.5hours on, 0.5hours off, 500hours)
Load Life(%-ohms)	±5%, (Power rating , 1.5hours on 0.5hours off, 500hours)
Filling	Cement

Metal Clad Wire Wound Resistors

IRV, IRH, ULV, ULH

Ordering Information

Type	Power	Winding	Resistance	Tolerance	Terminals	Insulation
IRV	500	-	0.1 ohm	J	FL300mm	4500V
IRV	60	- (inductive) N (non-ind)	See table	0.5% (D) 1.0% (F) 2.0% (G) 5.0% (J) 10% (K) -UL- 2.0% (G) 5.0% (J) 10% (K)	Flying Lead TAB#250 TAB4.3D TAB-L (NA)	1500Vac 2500Vac* 3000Vac 4500Vac 5400Vac
IRH	80					
	100					
	120					
	150					
ULV	300	Standard				
UHV	400	2500Vac				
	500					

Type	8 mm ²	5.5 mm ²	2 mm ²	1.25mm ²	UL3512 AWG10	UL3512 AWG14
IRH/IRV 60-150	-	-	0.1-0.99 ohm	1 - ohm	-	-
IRV/IRH 200-500	0.1-0.99 ohm	1.0-4.99 ohm	5.0 - ohm	-	-	-
ULH/ULV 60-120	-	-	-	-	-	0.1 ohm-
ULH/ULV 150	-	-	-	-	-	0.11 ohm-
ULH/ULV 200	-	-	-	-	0.1-0.15 ohm	0.16 ohm-
ULH/ULV 300	-	-	-	-	0.1-0.22 ohm	0.23 ohm-
ULH/ULV 400	-	-	-	-	0.1-0.30 ohm	0.31 ohm-
ULH/ULV 500	-	-	-	-	0.1-0.37ohm	0.38 ohm-

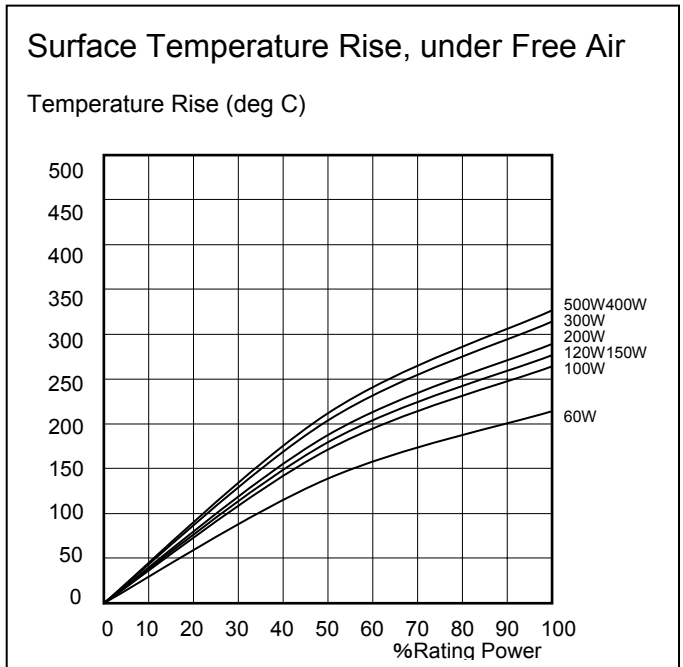
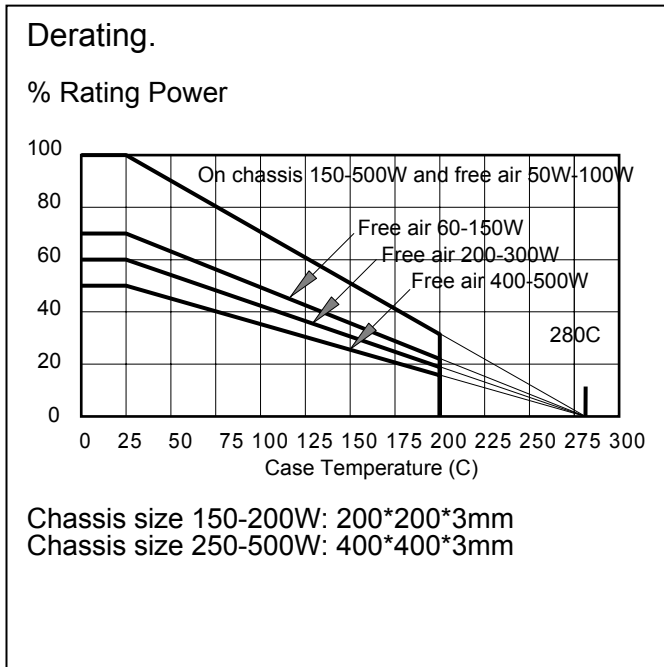

Note

- (1) Installation of a thermal protection switch is available. Please contact to info@nikkohm.com.
- (2) Flying lead length is assigned by your requirement.
- (3) Insulating voltage is assigned by your requirement.

600, 800, 1000, 1200 W
 Metal Clad Wire Wound Resistors
 IRV600, IRV800, IRV1000, IRV1200
 ULV600, ULV800, ULV1000, ULV1200

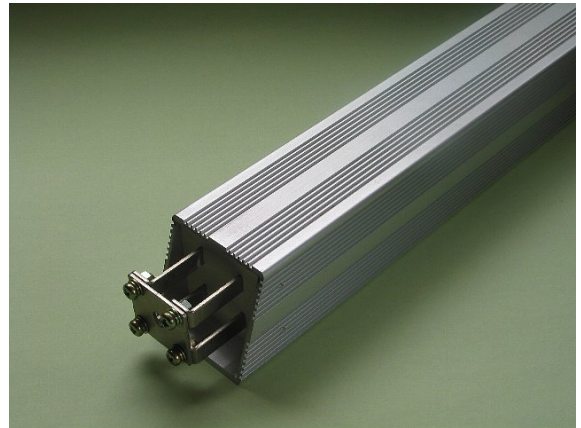

Features and Applications

600W to 1200W (on chassis) metal clad giant current durable wire wound resistors.
 Minimum resistance value of 0.1 ohm inductive and non inductive are available.
 Good heat conductive aluminum housed, full welding structure, no burn insulation and excellent space factor for installation.
 Current detection, motor control, recycle braking resistor, filter resistor and dumping resistor of the power electronics..

Dimensions (mm)

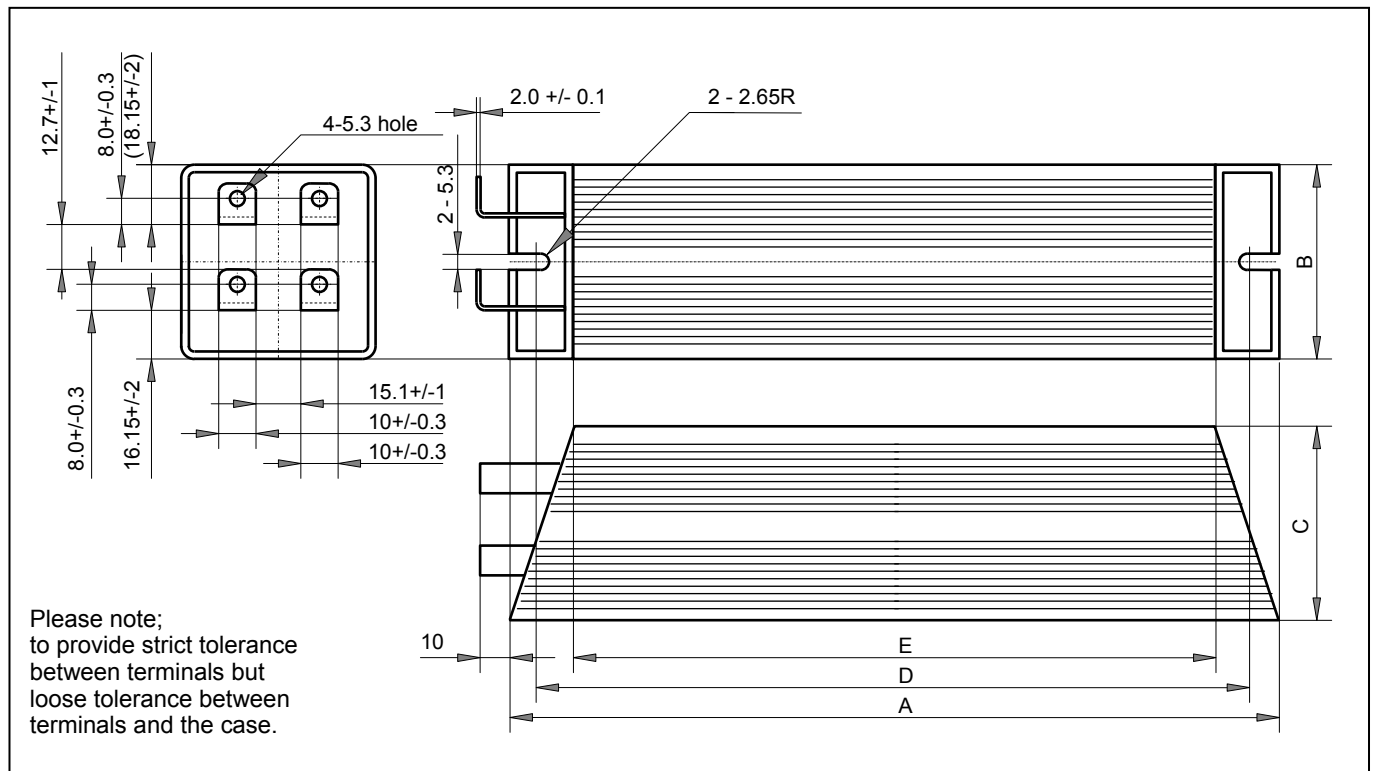

	A	B	C	D	E	WEIGHT grams	Flying Lead 8mm ²	Flying Lead 5.5mm ²
ULV/IRV600	±2	±0.5	±0.5	±2	±2	1165	0.1Ω~0.99Ω	≥ 1Ω
ULV/IRV800	235	61	59	216	195	1500		
ULV/IRV1000	286	61	59	266	245	1835		
ULV/IRV1200	335	61	59	316	295	1204		

600, 800, 1000, 1200W Metal Clad Wire Wound Resistors

IRV600, IRV800, IRV1000, IRV1200, ULV600, ULV800, ULV1000, ULV1200

Ordering Information

Type & Power IRV1200	Connection P	Ind./non-ind. N	Resistance 50 OHM	Tolerance J	Terminals L	Voltage 1500V
IRV600	P (parallel)	--- (inductive)	Any value	+/-0.5% (D)	L (metal)	3500V
IRV800	S (series)	N (non-ind.)		+/-1.0% (F)	FL (Fly wire)	4500V
IRV1000				+/-5.0% (J)		5400V
IRV1200				+/-10% (K)		
ULV600						
ULV800						
ULV1000						
ULV1200						

Note: Tolerance +/-5%(J) is standard.

Rated Power and Resistance

Type	Rated Power, On chassis	Rated Power, Free	Instant Power	Connection	Inductive /Non-inductive	Resistance Range (ohms) *1
ULV/IRV600	600W	300W	6KW	Parallel	Inductive	0.1 – 9.0
					Non-inductive	0.1 – 5.3
				Series	Inductive	9.1 - 94
					Non-inductive	5.4 – 21.2
ULV/IRV800	800W	400W	8KW	Parallel	Inductive	0.1 – 11.0
					Non-inductive	0.1 – 7.2
				Series	Inductive	11.1 – 112
					Non-inductive	7.2 – 28.8
ULV/IRV1000	1000W	400W	10KW	Parallel	Inductive	0.1 – 18.0
					Non-inductive	0.1 – 9.0
				Series	Inductive	18.1 - 140
					Non-inductive	9.1 - 36
ULV/IRV1200	1200W	480W	12KW	Parallel	Inductive	0.1 – 25
					Non-inductive	0.1 – 12
				Series	Inductive	25.1 - 160
					Non-inductive	12.1 - 48.0

Note *1: For out of resistance range please call factory.

Terminal connections

The resistor has four terminals as shown in figure, which are connected one resistor element to a pair of terminal.

Two resistors are connected as either Parallel or Series. The total resistance are specified as IRV series Resistance.

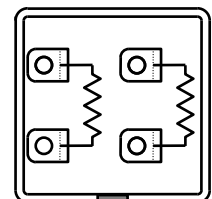

600,800,1000,1200W Metal Clad Wire Wound Resistors

IRV600, IRV800, IRV1000, IRV1200, ULV600, ULV800, ULV1000, ULV1200

Specifications and Performances

	Specifications				Remarks
Model	ULV/IRV600	ULV/IRV800	ULV/IRV1000	ULV/IRV1200	
Weight	1165gr	1500gr	1835gr	2304gr	
Absolute Tolerance	±0.5%(D), ±1.0%(F), ±5.0%(J), ±10.0%(K)				Standard:±5.0%(J)
Withstanding Voltage	1500 VAC, Optional 3500 VAC, 4500 VAC, 5400 VAC are available.				2mA leakage current
Insulating Resistance	minimum 20 MΩ				at 1000 Volts
Operating Temperature Range	-55 to +200 deg C				
Storage Temperature Range	-55 to +200 deg C				

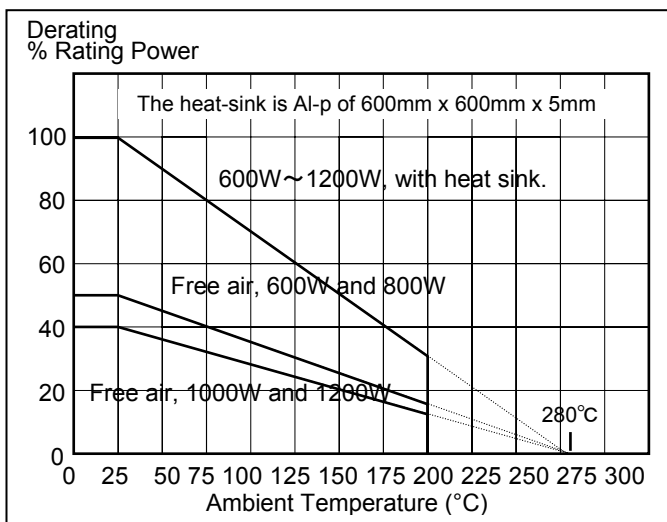
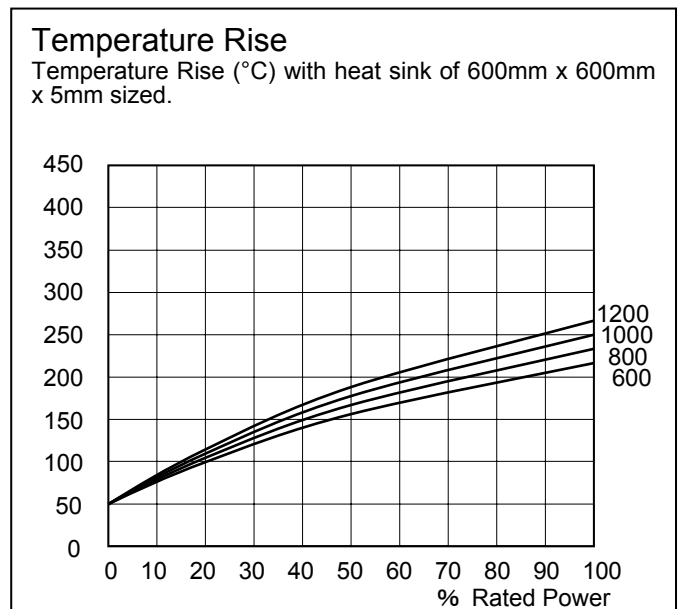
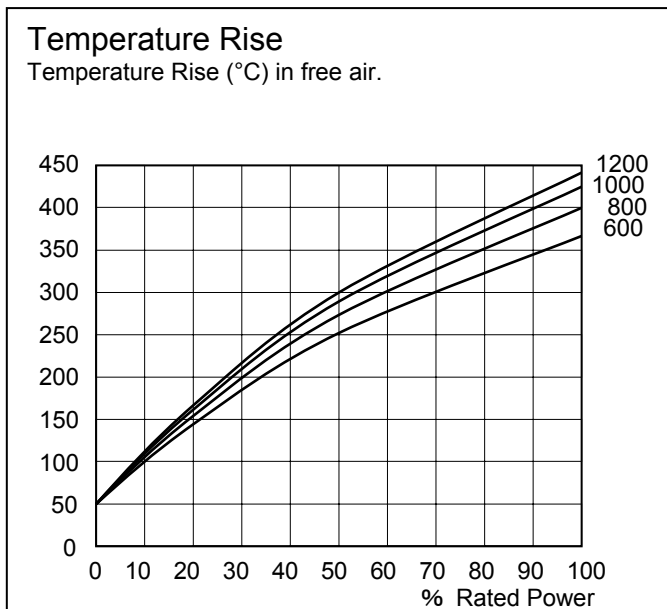

Note:

- (1) Resistor terminal have not metal short bar that makes series or parallel connection.
- (2) Flying lead terminals are available. Please call factory: info@nikkohm.co.jp.
- (3) Please request specification sheet at ordering. The sheet will help not to misunderstanding about actual specifications.

1600, 2000, 2400, 2800 W
 Metal Clad Wire Wound Resistors
 ULM1600, ULM2000, ULM2400, ULM2800
 IRM1600, IRM2000, IRM2400, IRM2800

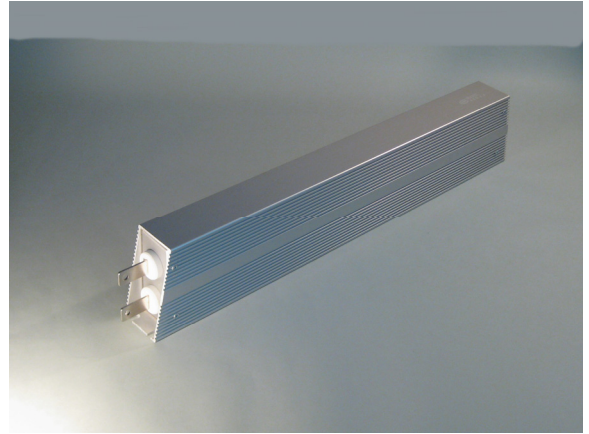

Features and Applications

- 1600W to 2800W (on chassis) metal clad wire wound resistors, UL certified (ULM).
- Minimum resistance value of 0.3 ohm and inductive and non inductive winding are available.
- Metal tab terminals and wire leaded terminals are available.
- Current detection, motor control, recycle braking resistor and dumping resistor of the power electronics.

Dimensions (mm)

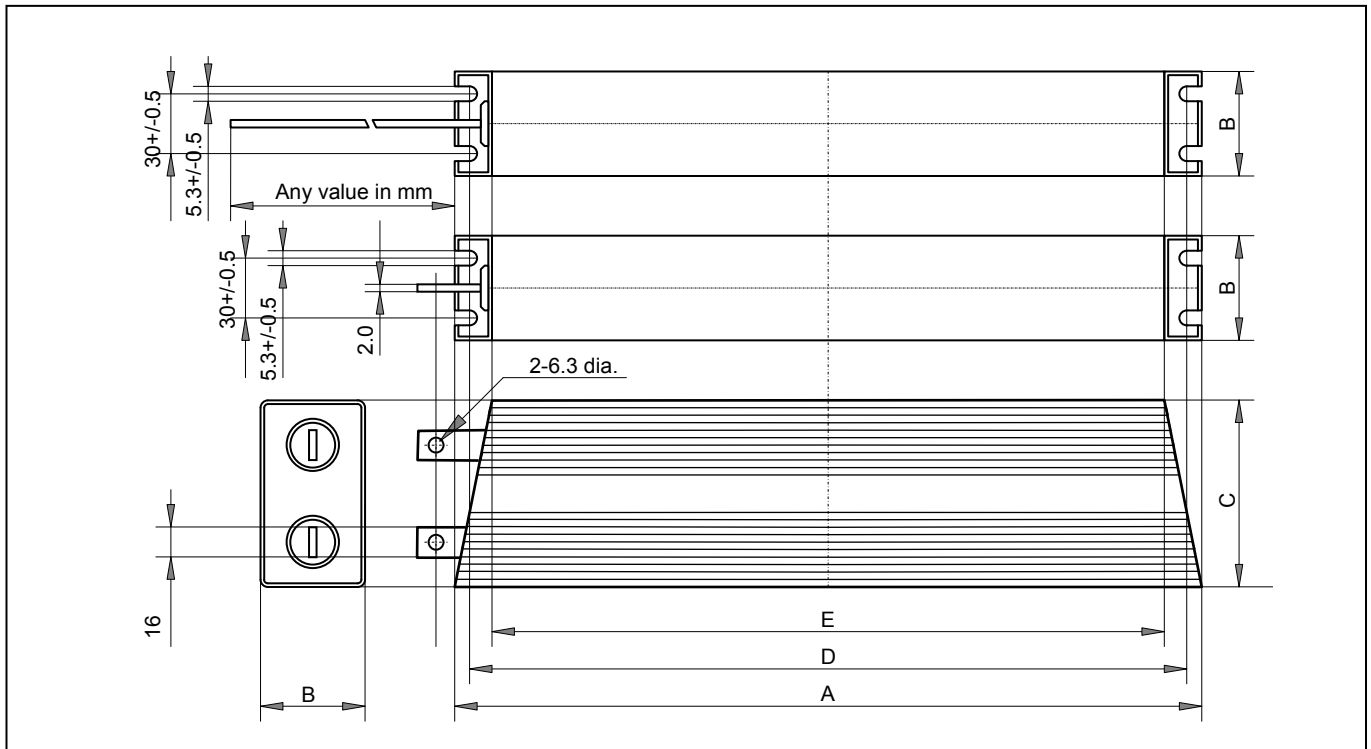

(mm)	A \pm 2	B \pm 0.5	C \pm 0.5	D \pm 2	E \pm 2	Weight (kg)
ULM1600	330	50	100	315	290	2.5
ULM2000	400	50	100	385	360	3.1
ULM2400	480	50	100	465	440	3.7
ULM2800	550	50	100	535	510	4.3
IRM1600	330	50	100	315	290	2.5
IRM2000	400	50	100	385	360	3.1
IRM2400	480	50	100	465	440	3.7
IRM2800	550	50	100	535	510	4.3

1600, 2000, 2400, 2800 W Metal Clad Wire Wound Resistors

ULM1600, ULM2000, ULM2400, ULM2800

IRM1600, IRM2000, IRM2400, IRM2800

Ordering Information

Type	Ind./non-ind.	Resistance	Tolerance	Terminals	Voltage
ULM2800	N	50 ohm	J	L	4500V
ULM1600	--- (inductive)	See table	+/-1.0% (F)	TAB (metal)	1500V
ULM2000	N (non-inductive)		+/-5.0% (J)	FL xxx mm (Fly wire)	2500V
ULM2400					3400V
ULM2800					4500V
IRM1600					
IRM2000					
IRM2400					
IRM2800					

Note: Tolerance +/-5%(J) is standard.

Rated Power and Resistance

Type	Rated Power on chassis	Rated Power in free air	Resistance (ohm)		Tolerance (%)
			Non inductive	Inductive	
ULM1600 / IRM1600	1600W	570 W	1.5 - 88.0	0.30 - 23.0	F (1%), J(5%)
ULM2000 / IRM2000	2000W	650 W	2.0 - 113.0	0.45 - 30.5	F (1%), J(5%)
ULM2400 / IRM2400	2400W	720 W	2.5 - 144.0	0.60 - 37.0	F (1%), J(5%)
ULM2800 / IRM2800	2800W	750 W	3.0 - 135.0	0.70 - 33.5	F (1%), J(5%)

Note: Resistance range in IRM1600-2800 model can extend to 10kohm, call factory.

Performances

Operating Temperature, Ambient	-55 deg C to +200 deg C	
Insulation Resistance	Minimum 20Meg Ohm	
Dielectric Withstanding Voltage	AC 1500, 2500, 3500, 4500V for 1 min. - 2mA	
Temperature Coefficient	+/- 260ppm/K in maximum	
Short Time Overload	+/- 3.0%	10 times rated power - 5 seconds
Moisture Resistance	+/- 3.0%	40 deg C, 95%RH, DC100V case-terminal, 500 hours
Thermal Shock	+/- 5.0%	Power rating 30 minutes - minus 25 deg C15 minutes
Vibration	+/- 2.0%	10Hz-55Hz-10Hz, 1 minutes, 2 hours, x-y-z direction
Humidity	+/- 3.0%	40degC, 95%RH, 0.1 rated power 1.5 hours on, 0.5 hours off, 500 hours
Load Life	+/- 5.0%	Rated power, 1.5 hours on 0.5 hours off, 500 hours

Flying Wire Lead and Resistance Selection

Type	3.5 sq mm	2.0 sq mm	UL3512 AWG10	UL3512 AWG14
ULM1600 / IRM1600	0.30 - 0.99 ohm	1.0 ohm ---	0.30 - 0.99 ohm	1.0 ohm ---
ULM2000 / IRM2000	0.45 - 0.99 ohm	1.0 ohm ---	0.45 - 0.99 ohm	1.0 ohm ---
ULM2400 / IRM2400	0.60 - 0.99 ohm	1.0 ohm ---	0.60 - 0.99 ohm	1.0 ohm ---
ULM2800 / IRM2800	0.70 - 0.99 ohm	1.0 ohm ---	0.70 - 0.99 ohm	1.0 ohm ---

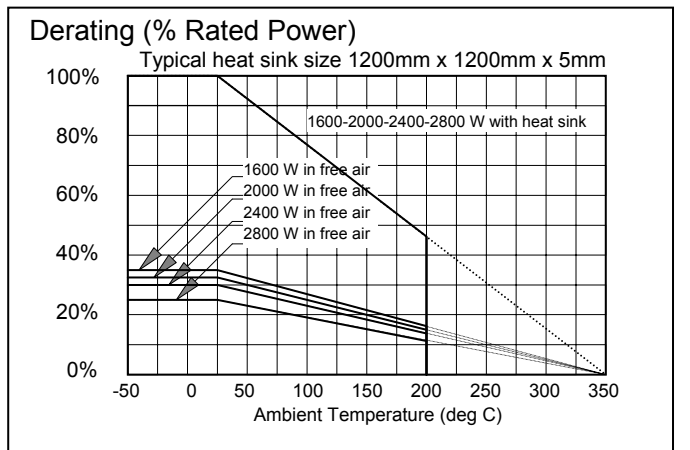
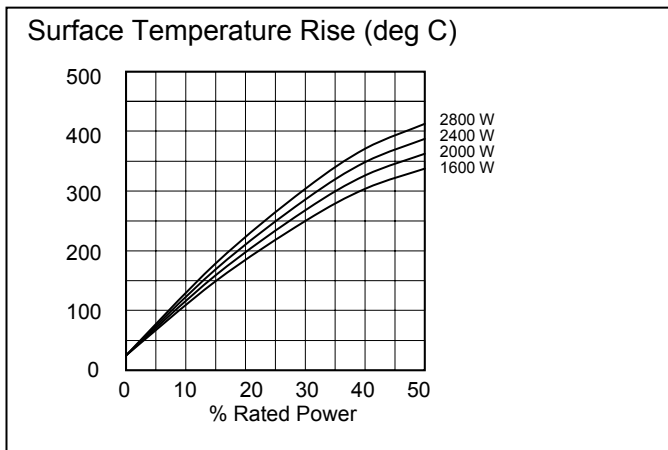

20150401

MBH / MBV
3000, 3600, 5000, 7200, 9600, 10800
Braking Wire Wound Resistors

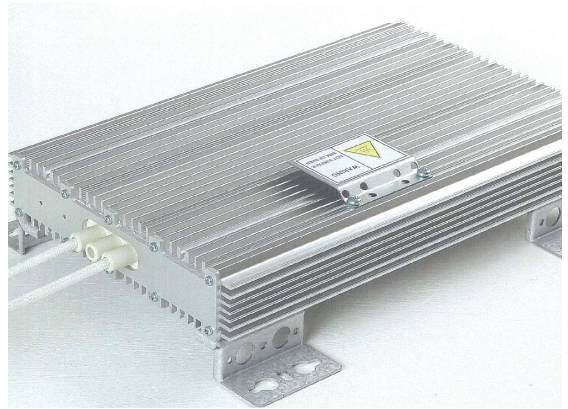

Features and Applications

3000W to 10800W (on chassis) metal clad wire wound braking resistors, small sized.
 Excluded aluminum housing provides strong mechanical structure. Minimum resistance value of 0.4 ohm and up to 3500V AC insulating voltage. Metal tab terminals and wire leaded terminals are available. Thermostat and terminal box are optional.
 Application includes sliding rate resistor, braking resistor and harmonic filter resistor of the windmill generator and power electronics.

Dimensions (mm, scale 1/4), MBH 3000

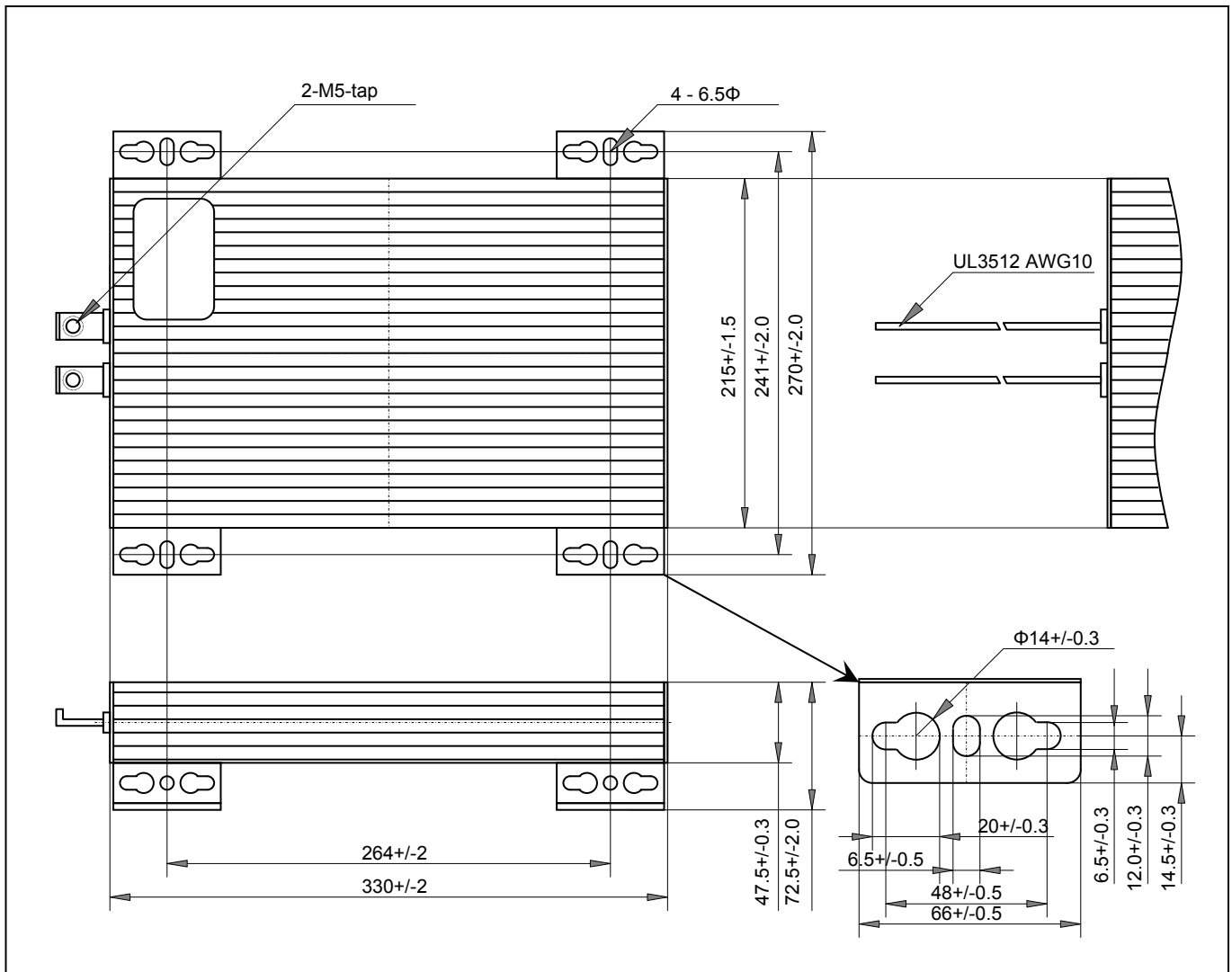

Braking Wire Wound Resistors

MBH / MBV

Ordering Information

Type	Identification	Resistance	Tolerance	Terminals	Voltage
MBH	3000	50 ohm	J	TAB	3500V
MBH	3000	> 0.4ohm - 150ohm	+/-5% (J)	TAB (metal)	1500V
MBV	3600	> 0.5ohm - 170ohm	+/-10%(K)	FL xxx mm (Fly wire)	2500V
	5000	> 0.6ohm - 180ohm			3500V
	7200	> 0.7ohm - 200ohm			
	9800	> 0.8ohm - 220ohm			
	10800	> 1.0ohm - 240ohm			

Rated Power and Pulse Power

Type	Rated Power in @25°C	Pulse Power (kW)				Resistance Value (ohms)	Resistance Tolerance
		5%CD	10%CD	20%CD	40%CD		
MBH/MBV 3000	1100 W	17.5	8.5	4.5	2.0	0.4 - 150	5% or 10%
MBH/MBV 3600	1300 W	20	10	5.5	2.5	0.5 - 170	
MBH/MBV 5000	1500 W	24	12	6.0	3.0	0.6 - 180	
MBH/MBV 7200	2000 W	35	16	8.0	4.0	0.7 - 200	
MBH/MBV 9800	2500 W	40	20	10.0	5.0	0.8 - 220	
MBH/MBV 10800	2900 W	46	23	11.5	6.0	1.0 - 240	

*CD: cycle duration of 120 seconds

Performances

Operating Temperature, Ambient	-----	-55 °C to +200 °C
Insulation Resistance	-----	Minimum 20Meg Ohm
Dielectric Withstanding Voltage	-----	AC 1500V, 2500V, 3500V for 1 minutes – leakage current 2mA
Temperature Coefficient	-----	+/- 200 ppm/K in maximum
Short Time Overload	+/- 5.0%	5 to 10 times rated power – 5 to 10 seconds
Moisture Resistance	+/- 3.0%	40 °C, 95%RH, DC100V case-terminal, 500 hours
Thermal Shock	+/- 3.0%	Power rating 30 minutes – minus 40 °C 15 minutes
Humidity	+/- 3.0%	40 °C, 95%RH, 0.1 rated power 1.5 hours on, 0.5 hours off, 500 hours
Load Life	+/- 5.0%	Rated power, 1.5 hours on 0.5 hours off, 500 hours
Net Weight	7.2kg	MBH3000

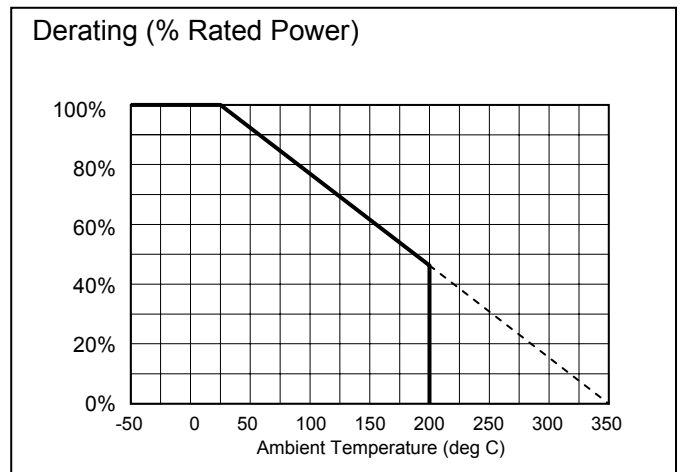
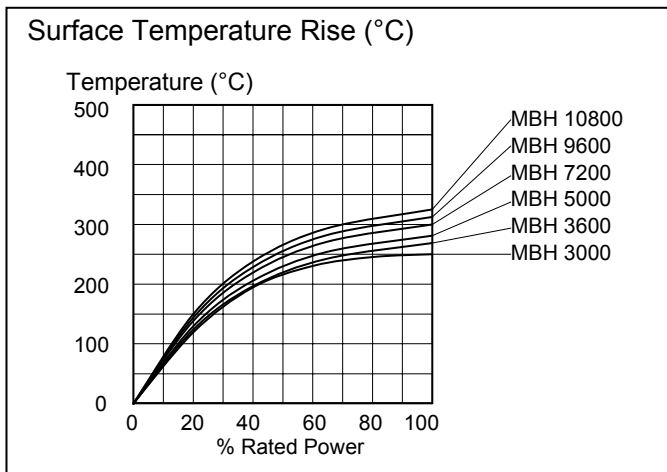

Braking Wire Wound Resistors, MBH / MBV

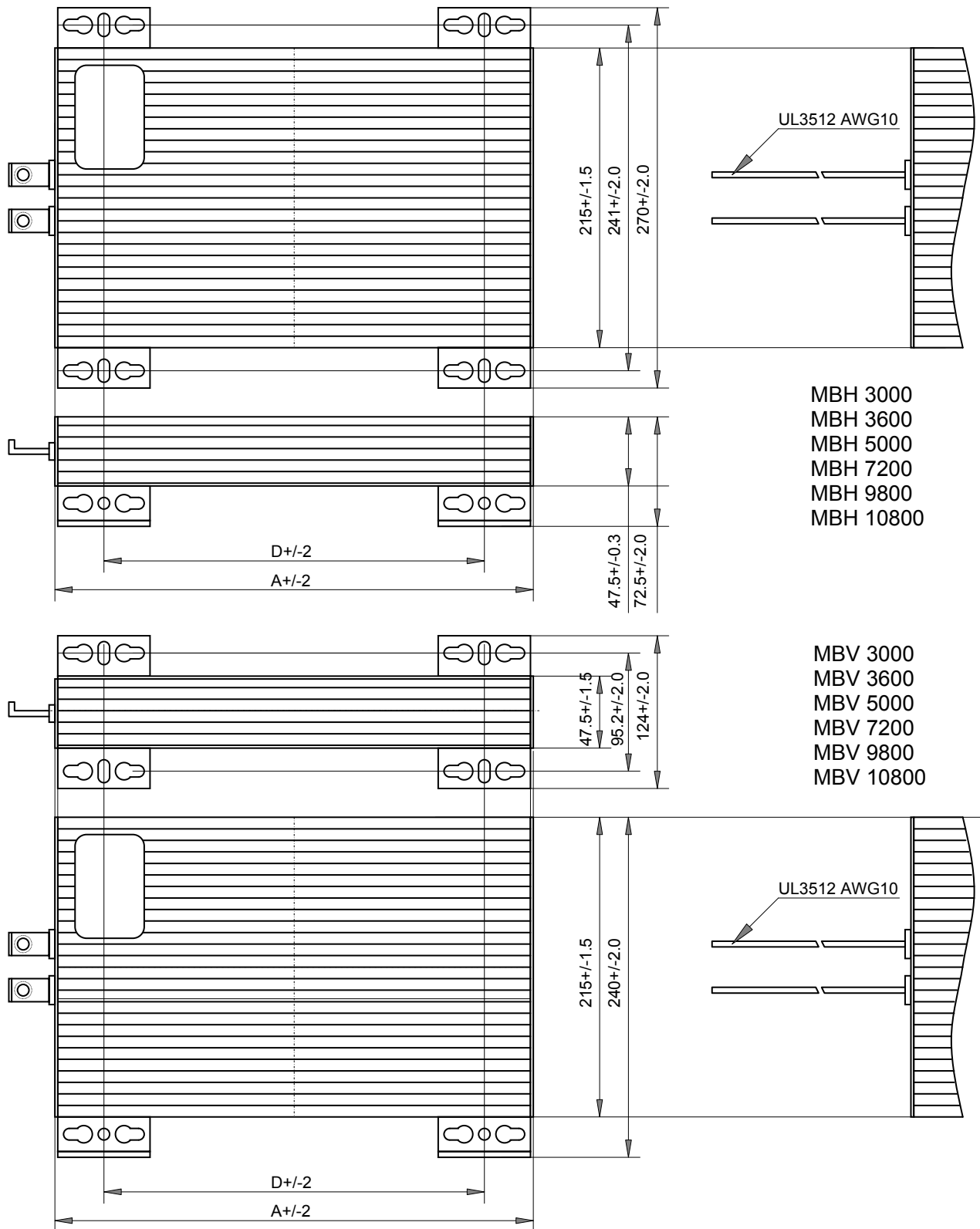

	A	D	Weight (kg)
MBH / MBV 3000	330	264	7.2
MBH / MBV 3600	400	334	8.2
MBH / MBV 5000	450	394	9.0
MBH / MBV 7200	560	494	10.5
MBH / MBV 9800	660	594	12.0
MBH / MBV 10800	760	694	13.5

3W, 5W, 7W Current Sense Resistors RCS2512, RCS3920, RCS5930

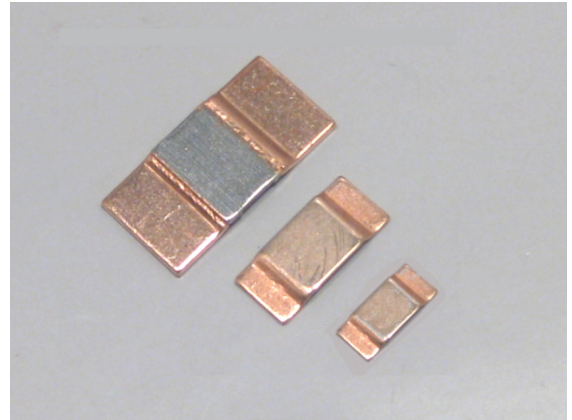

Features and Applications

Presenting surface mounted, low resistance value, low profile, low inductance and large impulse durable metal plate current detectors.

Tolerance +/-1%, +/-5 % and TC ±150ppm/°C or ±50ppm/°C in standard.

Current detection circuit for high speed CPU peripherals, battery charging current protections, DC-DC conversion modules, DC-AC conversion, servo-motor control electronics, intelligent power modules,

Dimension, Foot Pattern

RCS2512

RCS3920

RCS5930

Model		A	B	C	D	E	F
RCS2512	(mm)	6.35+/-0.15	3.02+/-0.2	D + E	(0.42)	(0.42)	1.14+/-0.400
RCS3920	(mm)	10.0+/-0.254	5.20+/-0.254	D + E	0.33 - 1.30	0.50	2.00+/-0.254
RCS5930	(mm)	15.0+/-0.254	7.75+/-0.254	D + E	0.27 - 1.23	0.50	4.00+/-0.254
RCS2512	(inches)	0.250+/-0.010	0.118+/-0.010	D + E	0.016	0.016	0.045+/-0.010
RCS3920	(inches)	0.395+/-0.010	0.205+/-0.010	D + E	0.0130 – 0.0510	0.020	0.080+/-0.010
RCS5930	(inches)	0.591+/-0.010	0.305+/-0.010	D + E	0.0105 – 0.0485	0.020	0.157+/-0.010

Dimensions 'D'

Model	Resistance	0.5 mΩ	1.0 mΩ	2.0 mΩ	3.0 mΩ	4 mΩ
RCS2512	(inches)	0.0334	0.0165	0.0181	0.0189	0.0141
RCS3920	(inches)	0.0300	0.0150	0.0270	0.0170	0.0130
RCS5930	(inches)	0.0180	0.0330	0.0155	0.0105	---

Dimensions, Foot print

Model		G	H	J
RCS2512	(inches)	0.071+/-0.010	0.134+/-0.005	0.133+/-0.010
RCS3920	(inches)	0.106+/-0.010	0.220+/-0.005	0.244+/-0.010
RCS5930	(inches)	0.205+/-0.010	0.220+/-0.005	0.344+/-0.010

3W, 5W, 7W Current Sense Chip Resistors

RCS2512, RCS3920, RCS5930

Specifications

Model	Size mm	Power Rating W	Tolerance %	Resistance Value mΩ	Weight g/1000 pieces
RCS2512	6.36mm x 3.02mm	3.0	1.0, 5.0	0.3, 0.5, 1.0, 2.0, 3.0, 5.0	120
RCS3920	10mm x 5.2mm	3.0	1.0, 5.0	0.3, 0.5, 1.0, 2.0, 3.0, 4.0	280
RCS5930	15mm x 7.75mm	5.0	1.0, 5.0	0.2, 0.5, 1.0, 2.0, 3.0	400

Ordering Information

Type	Resistance	Tolerance	Option Code	Remarks
RCS3920	R001	J	Z01	4000pcs/reel
RCS2512	R0005	J (5%) std	Z00	Bulk
RCS3920	R001	F (1%)	Z01	Tape Reel
RCS5930	R002			
	R003			
	R004			

Specification and Performances

	RCS2512	RCS3920	RCS5930	Conditions
TCR	±150ppm/°C	±50ppm/°C	±50ppm/°C	-55°C to +60 °C range
Rating Current	45A	54A	70A	at 1mohm, and rated power
Maximum Current	67A	81A	105A	2.5 seconds one time
Series Inductance	1nH	2nH	5nH	
Operating Temp.	-55 °C to 175 °C			
Short Time Overload	+/-0.5%+0.5mohm)			maximum current, 2.5seconds.
Low Temperature Storage	+/-0.5%+0.5mohm)			-55°C, 24hours
High Temperature Storage	+/-1.0%+0.5mohm)			+170°C, 1000hours
Heat Shock	+/-0.5%+0.5mohm)			-55°C to +125°C, 20min. interval, 5min. 5cycles
Vibration	+/-0.5%+0.5mohm)			10-2000Hz, 1.5mm/20gr, 2hours
Soldering Heat	+/-0.25%+0.5mohm)			260C+/-5°C, 10+/-1seconds.
Solder ability	90%/terminal surface			
Humidity	+/-0.5%+0.1mohm)			85d°C, 85%RH, dc 0.1W, 1000 hours
Load Life	+/-0.5%+0.1mohm)			25°C, dc rated power, 90min ON, 30min OFF, 1000hours

Derating

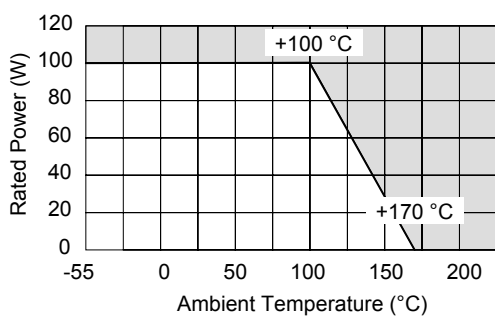

Materials and Structure

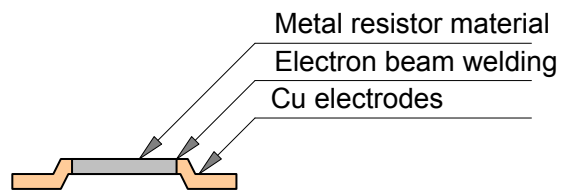

Taping

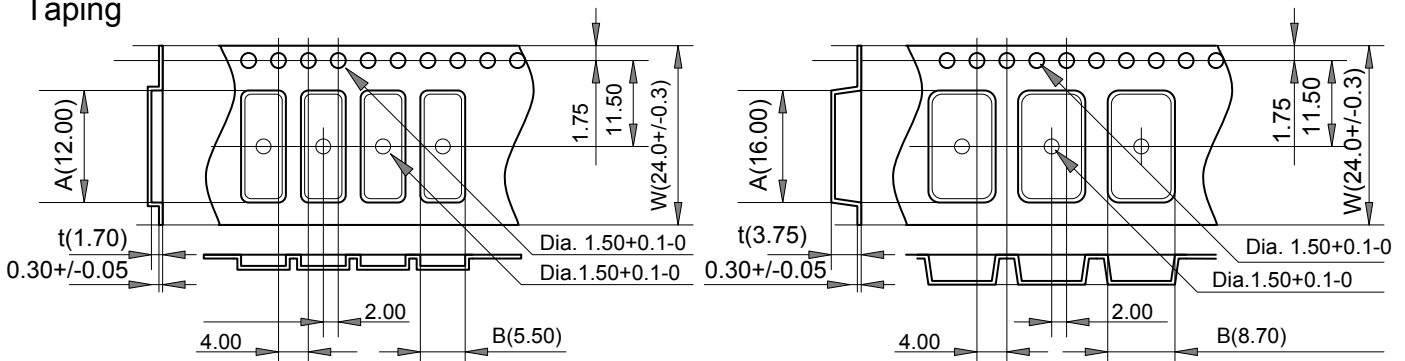

4 TERMINALS THROUGH HOLE
CURRENT SHUNT RESISTORS

RCS3820

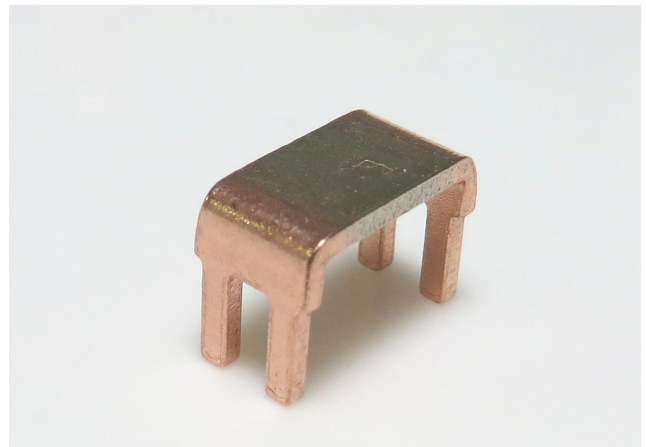

Features and Applications

- Rated power 5W, operation current 100A at 0.3mΩ resistance value.
- Four terminals configuration.
- Excellent long term stability.
- Operation temperature range -55°C to +175°C satisfies automotive applications
- Applications include current detect of inverter-converter, battery management, electric tool.

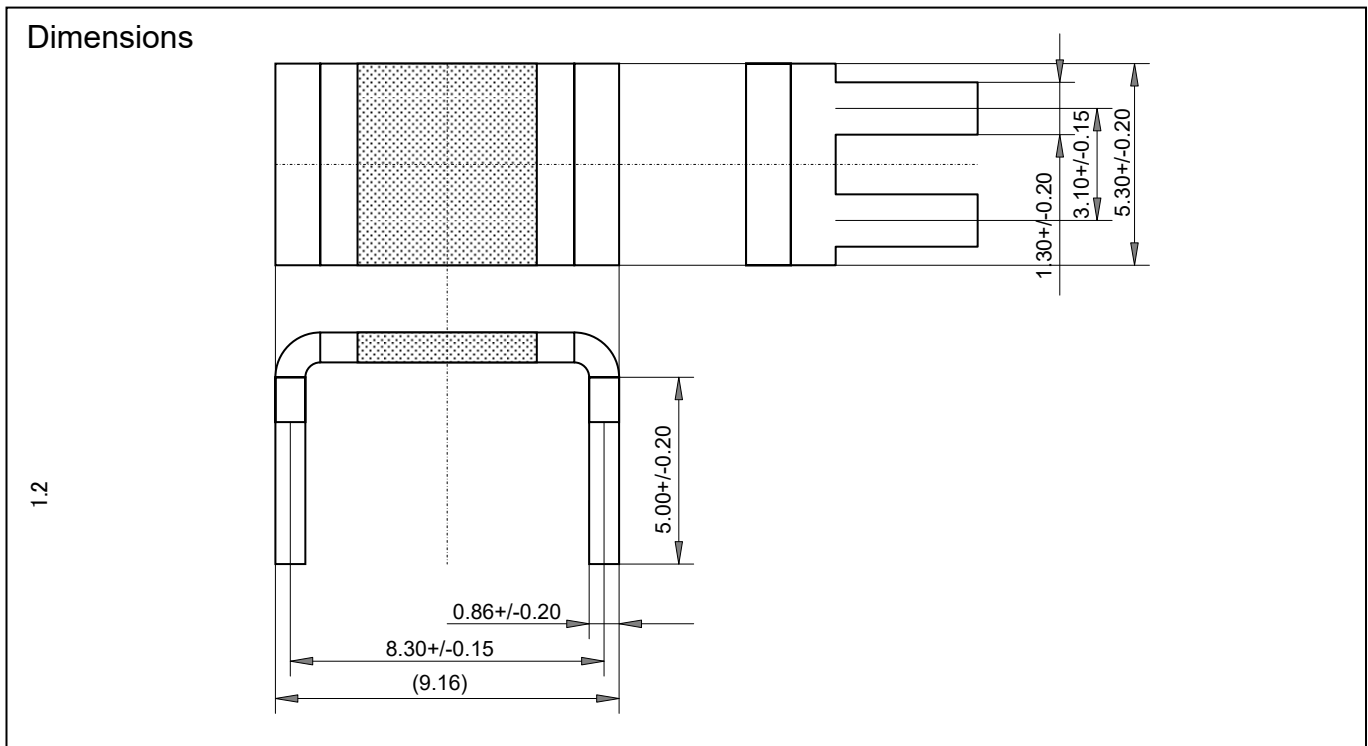

Ordering Information

Type	TCR	Resistance	Tolerance	Code	Note
RCS3820	A	R0005	J	Z00	
RCS3820	A (100ppm/K)	R0003	J (5%)	Z00	RoHS, bulk package
		R0005			
		R001			
		R002			

4 TERMINALS THROUGH HOLE CURRENT SHUNT RESISTORS RCS3820

Specifications and Performances

Items	Specifications	Conditions
Rating Power	5 Watts	Ambient temperature -55°C to +100°C
Resistance Range	0.3mΩ, 0.5mΩ, 1.0mΩ, 2.0mΩ	
TCR	100 ppm/K	-20°C to +125°C
Resistance tolerance	+/-5%	
Operation Temp.	-55 to +175 °C	
Short time overload	ΔR: +/-1%+0.0005Ω	5 times of rated power, 5 seconds
High temperature exposure	ΔR: +/-1%+0.0005Ω	+125°C, 1000 hours
Load Life	ΔR: +/-1%+0.0005Ω	Apply rated power, 1.5hours ON 0.5hours OFF 1000hours
Temperature cycle	ΔR: +/-1%+0.0005Ω	5 cycles, on board

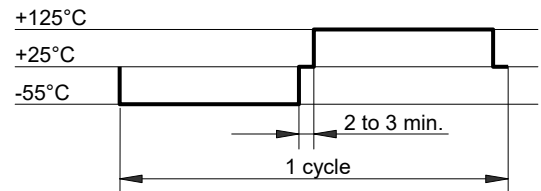

Derating

% Power Rating

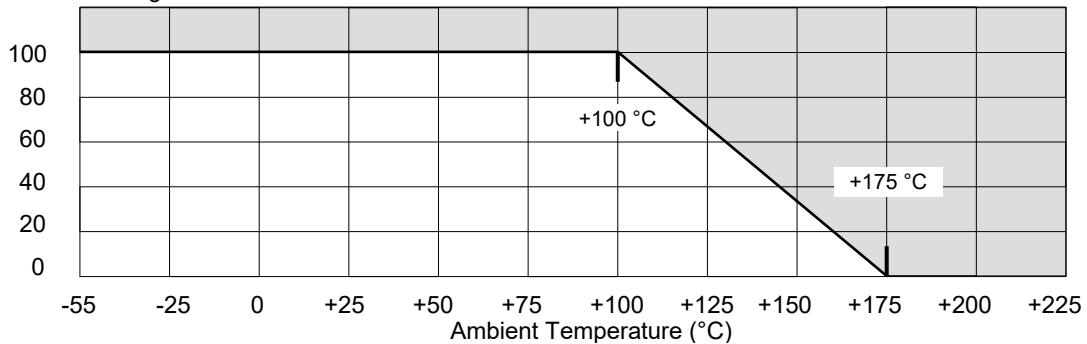

Foot Pattern

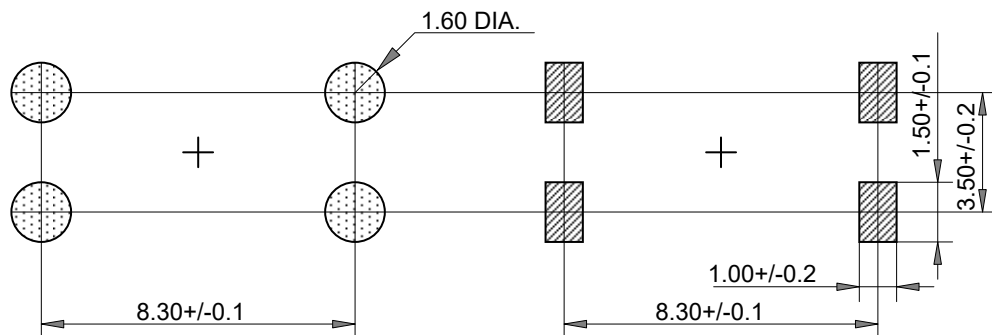

3W CURRENT SENSING RESISTORS

RCS3 (170A)



Features and Applications

Rating current 170A (0.1mohm-3W, current detecting resistors for electric equipments.
 Excellent long term stability and less than 80ppm/C TCR are realized by using Ni alloy and fully fine welding structure.
 Simple 4-ports Kelvin structure is easy to install large current bus-bar.
 Current detection in precision power source, constant current source, industrial power conversion circuit, battery charging control, constant electronic load and etc.

Dimensions

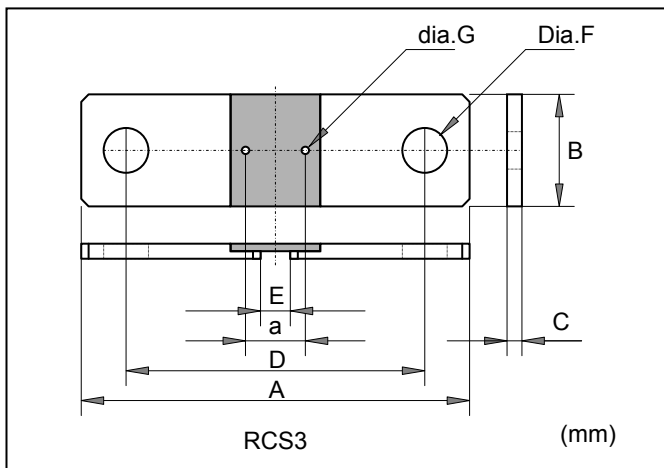

RCS3	(mm)	(inch)
A	55.0	2.165
B	15.0	0.591
C	2.0	0.079
D	40.0	1.575
F	6.2	0.244
G	0.8	0.031
E (0.1mohm)	7.0	0.275
E (0.2mohm)	9.6	0.378
E (0.3mohm)	12.0	0.472
E (0.4mohm)	14.5	0.571
E (0.5mohm)	17.5	0.689

Rating current and Maximum, RCS3

milliohm	Rating Current(A)	Max Current (A)
0.1	173	865 / 5sec.
0.2	122	610 / 5sec.
0.3	100	500 / 5sec.
0.4	86	430 / 5sec.
0.5	77	385 / 5sec.

Note (1): Rating and maximum current are specified in connecting to bus-bar, not at standing alone resistor in free air

Ordering Information

Type	TCR	Resistance Value	Tolerance	Note
RCS3	A	R0001	F	Z00
RCS3	A (0/+100ppm/°C)	R0001	F(+/-1%)	Z00
		R0002	J(+/-5%)	
		R0003		
		R0004		
		R0005		

3W CURRENT SENSING RESISTORS

Specification and Performance

Items	Specification
Type	RCS3
Resistance	0.1 to 0.5 milliohm
TCR	+0 to +100ppm/°C (A)
Tolerance	+/-1% (F) and +/-5% (J)
Rating Power	3W
Maximum Power	100W / 0.1seconds
Rating Current	See upper table
Operating Temperature	-55°C - +175°C
Storage Temperature	-55°C - +125°C

RCS3 (170A)

Power Derating

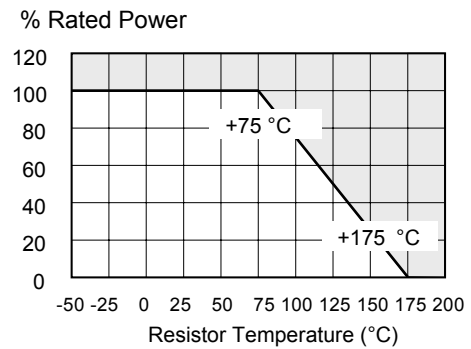

Pulse Energy (RCS3AR0001FZ00)

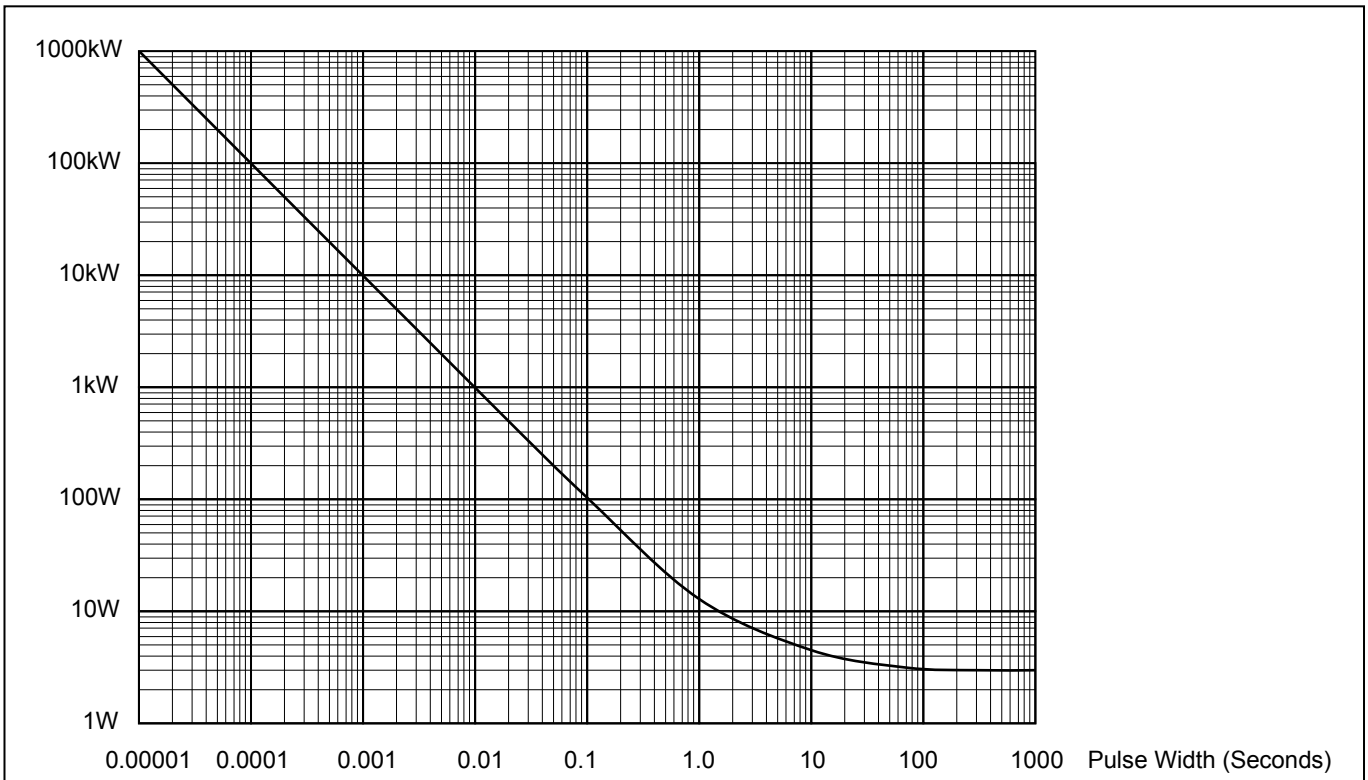

Applications

Note:

- (1) When RCS current detector is attached to current bus, mechanical strain shall be rejected from the resistor as shown in above illustration.
- (2) Resistance shall be made by calculating from DC voltage on detecting terminal at application of current through current terminals..
- (3) Voltage output Copper pins shall be contacted to Copper terminals of resistor.

Recommended installation is shown in right hand drawing. Terminal shall be used R type (JST38-S5) with AWG#2. Bus bar shall be used Cu bar, 15.5mm width and 2mm thick. Cross area will be 31mm square. Screw is M5-M6.

3W BUS BAR CURRENT SHUNT RESISTORS

RCS551520, RCS551521

RCS551522, RCS551523

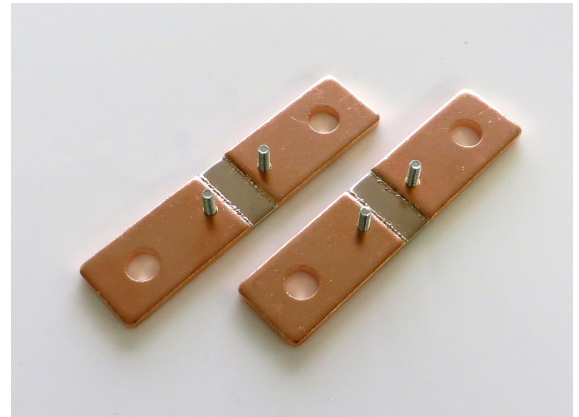

Features and Applications

Rating current 3W - 170A (0.1mohm), bus bar shunt resistors for electric equipments.
 Excellent long term stability and less than 100ppm/C TCR are realized by using Ni alloy and fully fine welding structure.
 Simple 4-ports Kelvin structure is easy to install large current bus-bar.
 Current detection in precision power source, constant current source, industrial power conversion circuit, battery charging control, constant electronic load and etc.

Dimensions (mm)

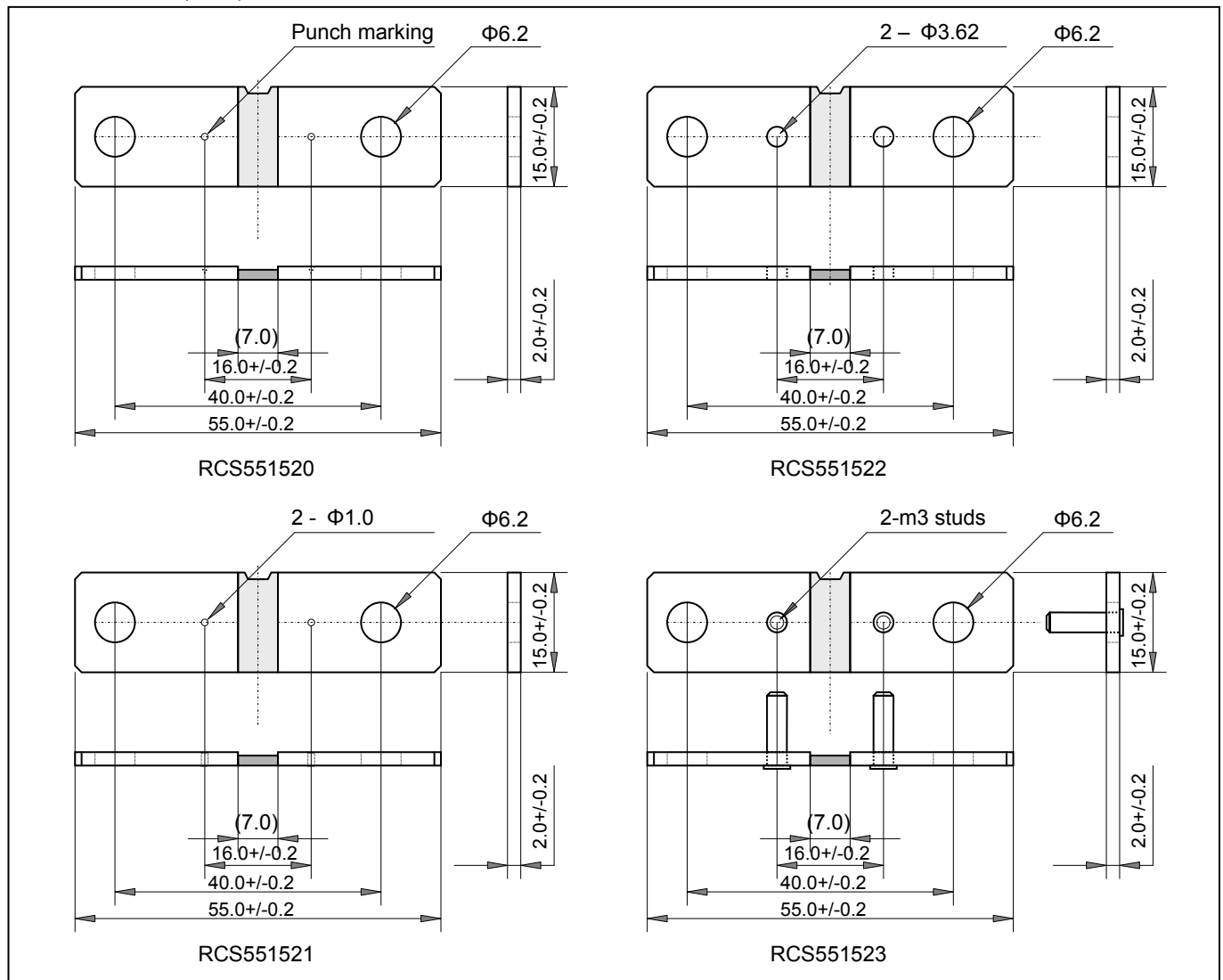

3W CURRENT SENSING RESISTORS

RCS551520, RCS551521, RCS551522, RCS551523

Ordering Information

Type	TCR	Resistance Value	Tolerance	Note
RCS551520	A	R0001	F	Z00
RCS551520	A (0/+100ppm/°C)	R00005	F(+/-1%)	Z00
RCS551521		R0001	H(+/-3%)	
RCS551522			J(+/-5%)	
RCS551523				

P/N RCS551520 shows dimensions in mm, 55mm length x 15mm width x 2mm thickness x without holes for voltage detection. Last digit '0' shows position marking, 1 shows 1.0mm hole diameter, 2 is 3.6mm., 3 shows with M3 stud.

Specifications and Performances

Items	Specification
Type	RCS551520
Resistance	0.1 to 0.5 milliohm
TCR	+0 to +100ppm/°C (A)
Tolerance	+/-1% (F), +/-3.0%(H) and +/-5% (J)
Rating Power	3W
Maximum Power	100W / 0.1seconds
Rating Current	See upper table
Weight	15 grams
Operating Temperature	-55°C - +175°C
Storage Temperature	-55°C - +125°C

Power Derating

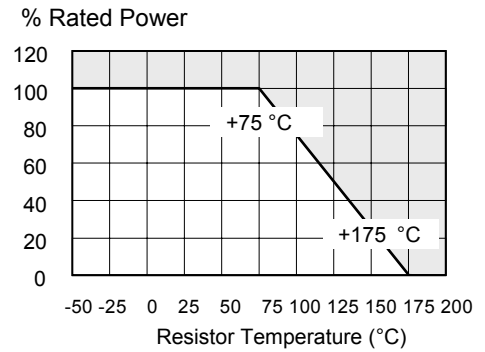

Pulse Energy (RCS551520AR0001FZ00)

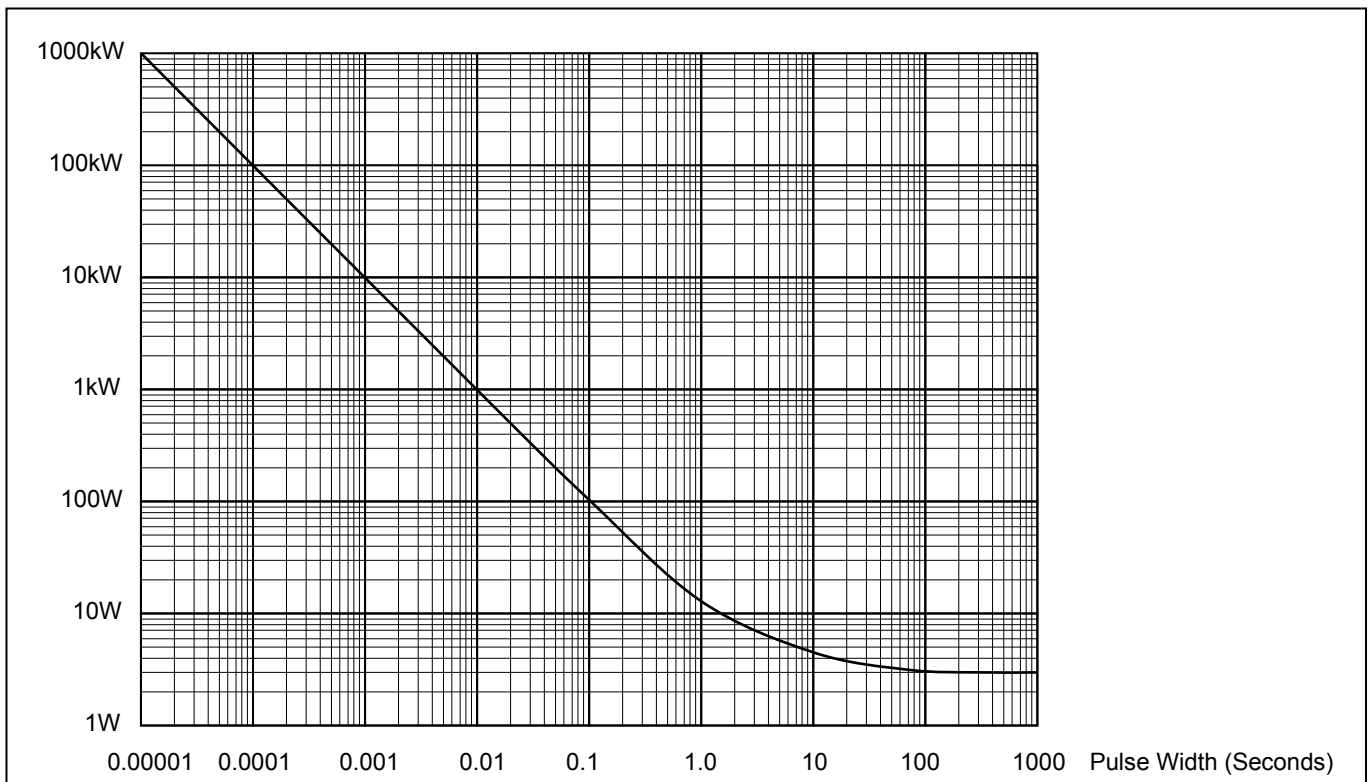

20170801

15W CURRENT SENSING RESISTORS
 RCS842030, RCS842031, RCS842032
 RCS842033 (380A–0.1mohm)

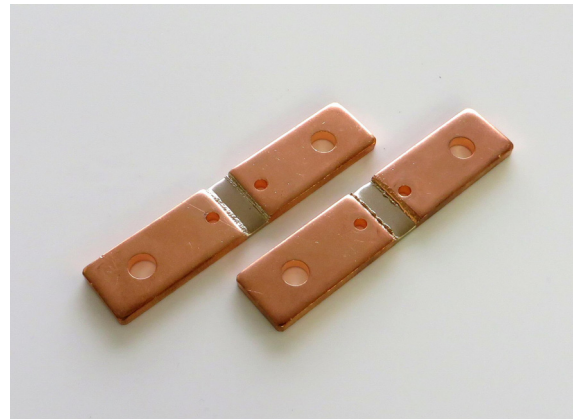

Features and Applications

Four terminals bus-bar metal strip current shunt of all EB weld and passivate surface, Ni plating is available in option.
 Up to 15W continuous power and maximum current 380A – 38mV (100uΩ)
 84mm x 20mm x 3mm dimension has various voltage terminal style.
 Very low inductance and high pulse current rating.

Up to 15W continuous power and maximum current 350A (0.1mohm)
 High pulse power rating
 Very low inductance

Dimensions

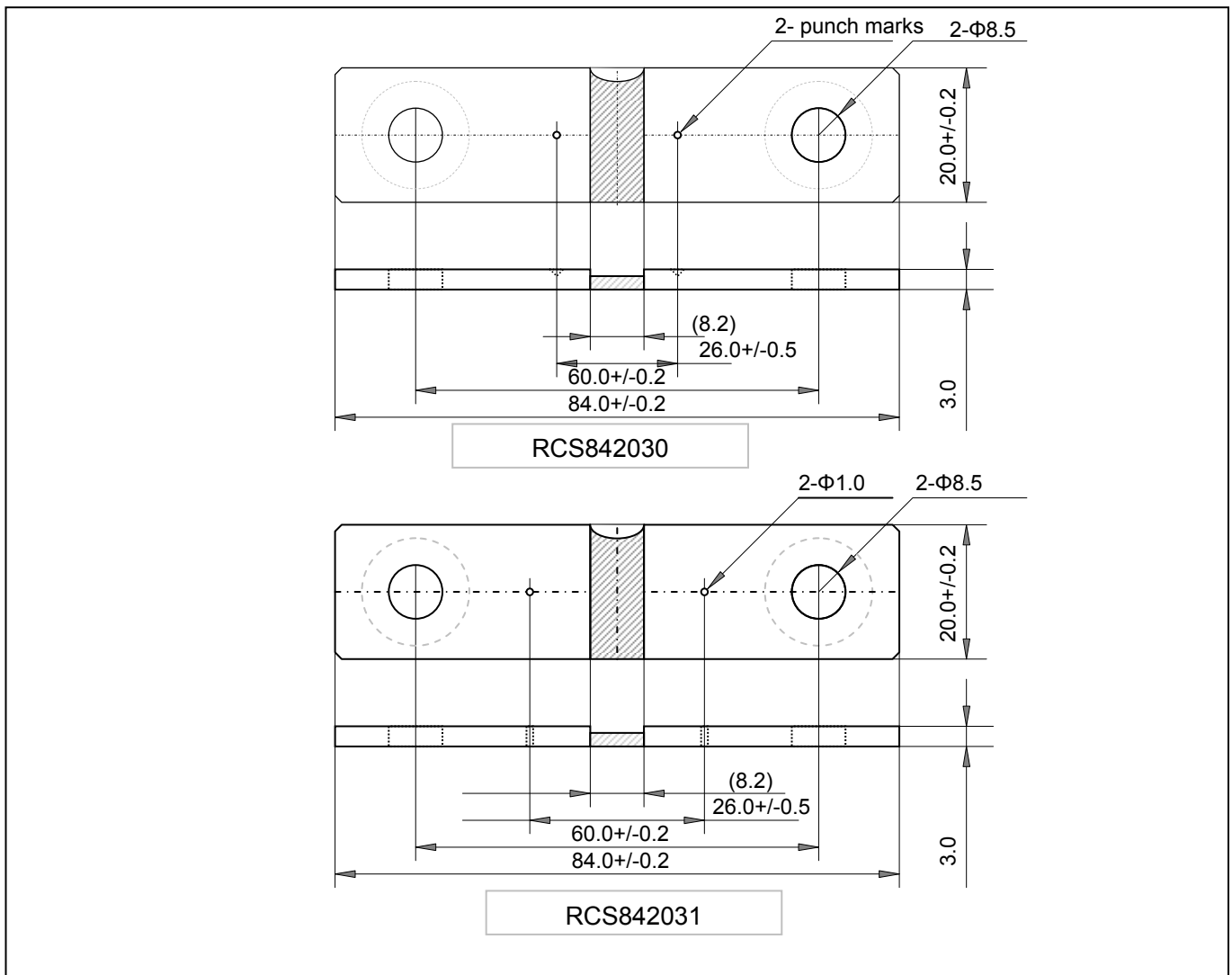

15W CURRENT SENSING RESISTORS

RCS842030, RCS842031, RCS842032, RCS842033 (380A–0.1mohm)

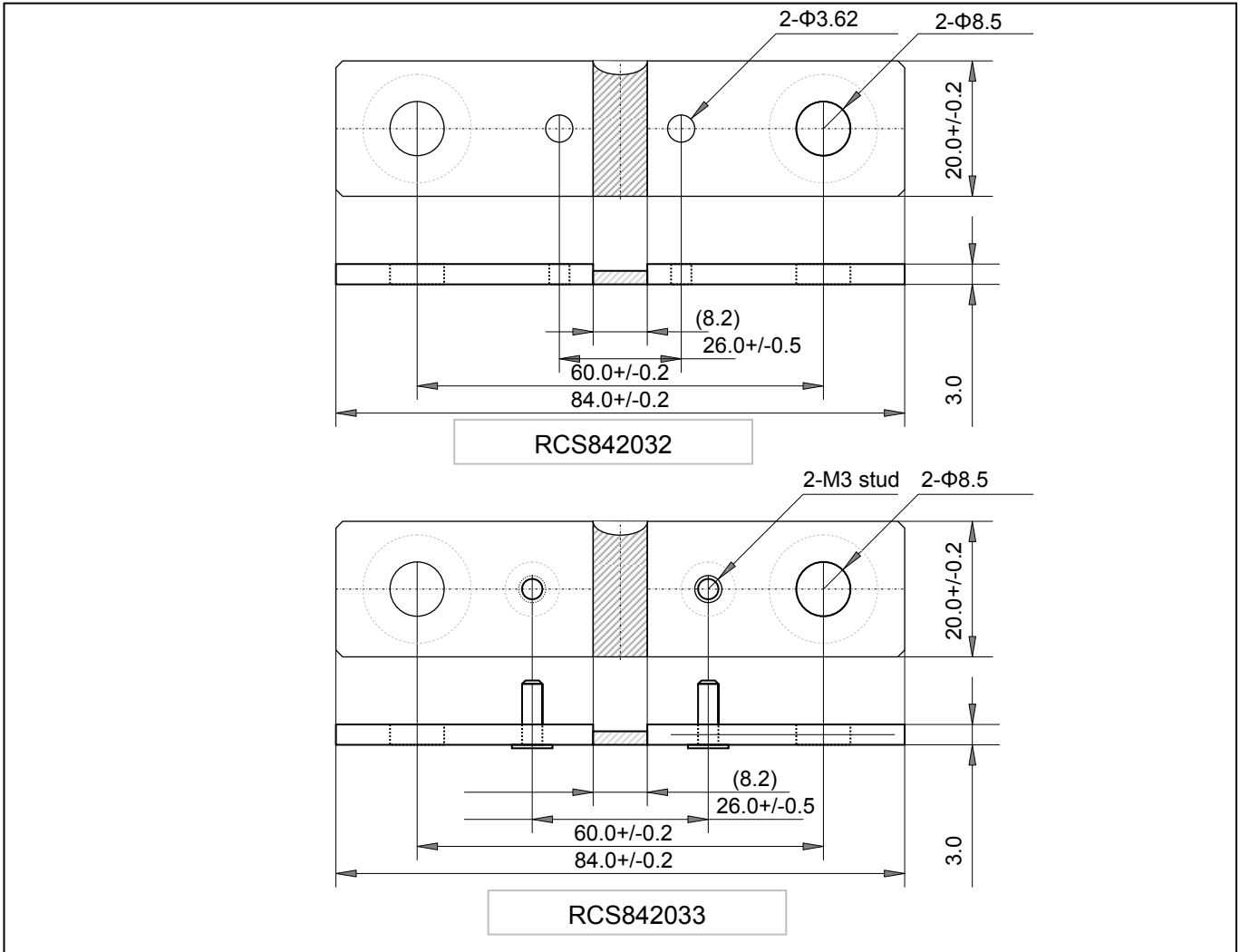

Ordering Information

Type	TCR	Resistance	Tolerance	Note
RCS842030	A	R0001	F	Z00
RCS842030	A (100ppm/°C)	R00005	F (+/-1%)	Z00
RCS842031		R0001	H (+/-3%)	
RCS842032			J (+/-5%)	
RCS842033				

Specification and Performance

Resistance	0.05 to 0.1 milliohm
TCR	+0 to +100ppm/°C (A)
Tolerance	+/-1% (F), +/-3%(H) and +/-5% (J)
Rating Power	15W
Rating Current	See upper table
Operating Temperature	-55°C - +175°C
Storage Temperature	-55°C - +175°C
Weight	30 grams

Power Derating

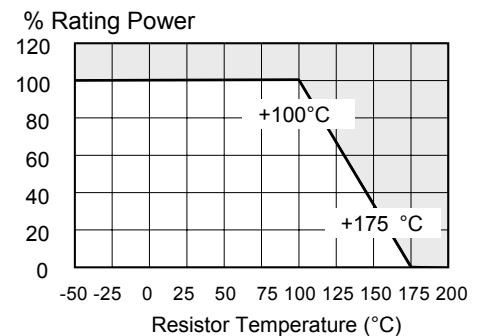

36W CURRENT SHUNT RESISTORS
RCS85184x R0001J (600A – 60mV)

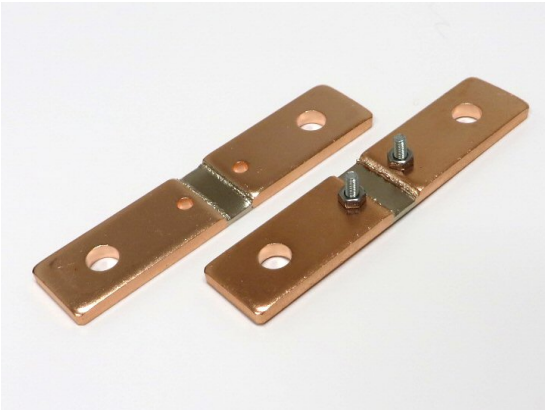

Features and Applications

Four terminals bus-bar metal strip current shunt of all EB weld and passivate surface, Ni plating is available in option.
 Up to 36W continuous power and maximum current 600A – 60mV (100uΩ)
 85mm x 18mm x 4mm dimension has various voltage terminal style.
 Very low inductance and high pulse current rating.
 Excellent long term stability, less than 250ppm/°C TCR, excellent frequency characteristics and low thermal EMF (<10uV/°C)
 Applications include battery charging current control of automotive electronics, load current detection of power electronics, inverter, UPS, motor control and electronic load equipments.

Dimensions

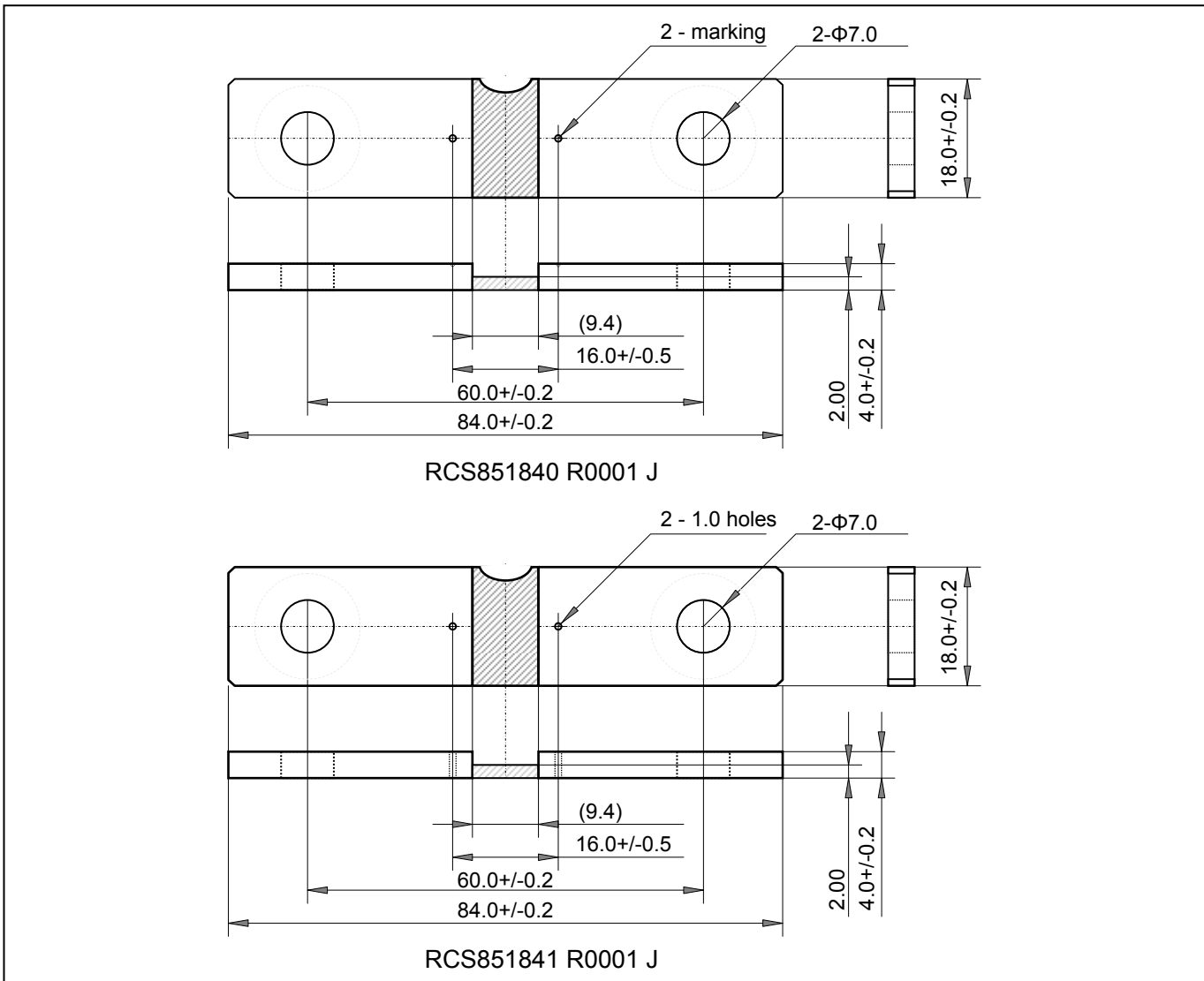

36W CURRENT SHUNT RESISTORS

RCS85184x R0001J (600A – 60mV)

RCS851842 R0001J (600A – 60mV)

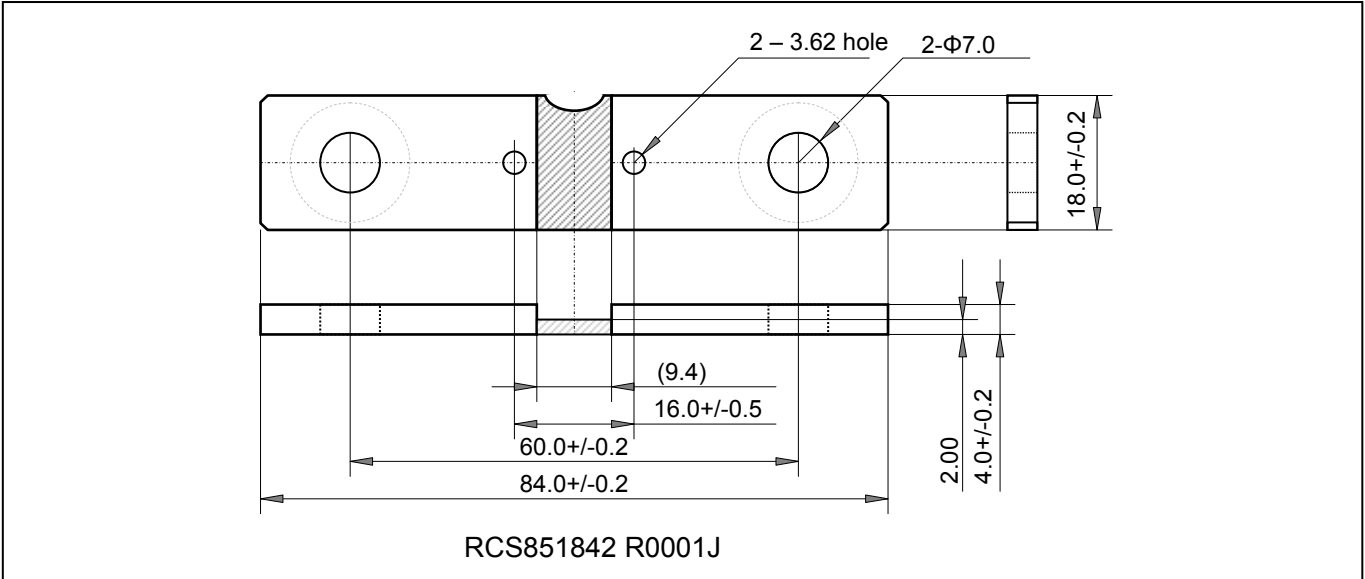

RCS851843 R0001J (600A – 60mV)

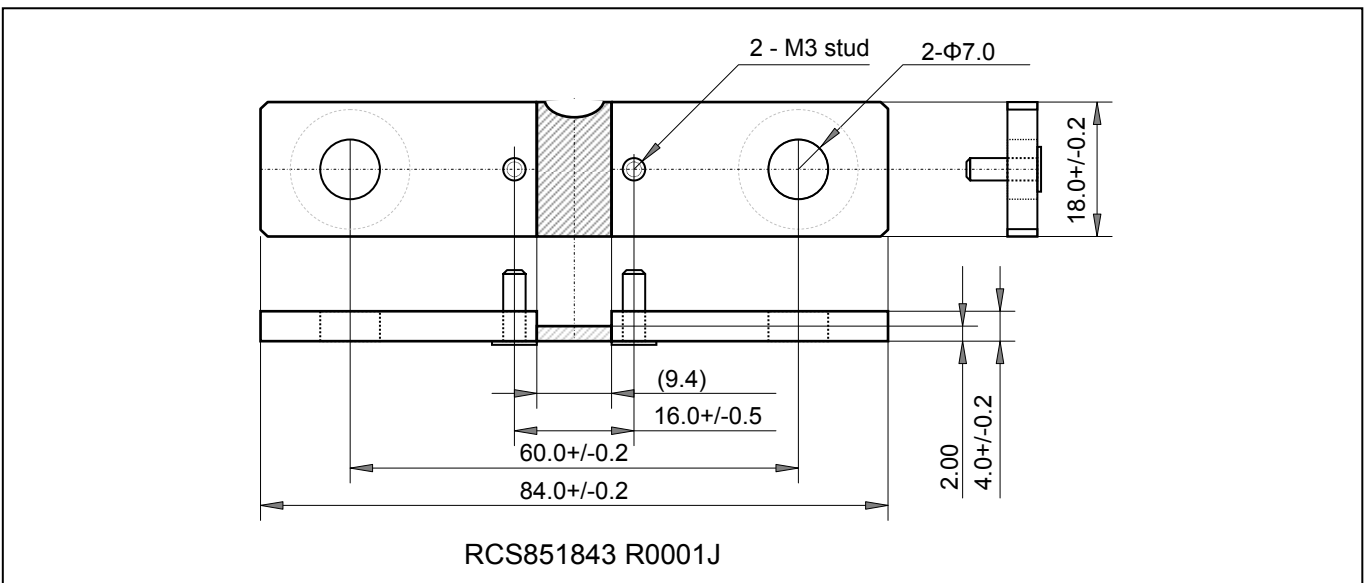

Dimensions of Resistor

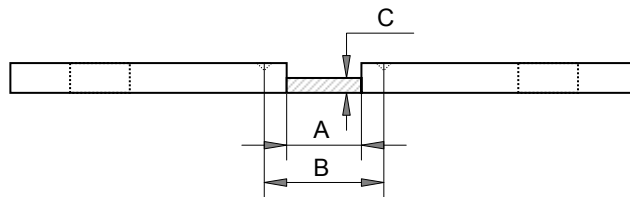

Resistance (Ω)	Material	A (mm)	B (mm)	C (mm)
0.0005	Mn-Cu	3.68	8.71	2.00
0.0001	Mn-Cu	9.40	12.57	2.00
0.000125	Mn-Cu	12.19	14.86	2.00

36W CURRENT SHUNT RESISTORS

RCS85184x R0001J (600A – 60mV)

Ordering Information

Type RCS851840	TCR A	Resistance R0001	Tolerance J	Note Z00
RCS851840	A (200ppm/°C)	R00005	F (+/-1%)	Z00
RCS851841		R00010	H (+/-3%)	
RCS851842		R000125	J (+/-5%)	
RCS851843				

Performance

	Specifications	Conditions
Power rating	36W	
Tolerance	+/-1%, +/-3%, +/-5%	
Typical resistance Value	100uΩ	50uΩ, 125uΩ
Thermal shock	+/-0.5%	-55°C - +150°C, 1000cycle, 15 minuets at each temperature
Short time overload	+/-0.5%	5 times rated power, 5 seconds
Low temperature storage	+/-0.5%	-55°C for 24 hours
High temperature exposure	+/-1.0%	+170°C for 1000 hours
Humidity	+/-0.5%	+85°C, 85% RH, 0.1 x rated power, 1000hours
Mechanical shock	+/-0.5%	100G for 6ms, 5 times
Vibration	+/-0.5%	Frequency changed 10Hz to 2000Hz in 1 minuets, x-y-z, 12 hours
Load life	+/-1.0%	1000 hours at 70°C , 1.5hours ON, 0.5hours OFF
Weight	40 grams	---

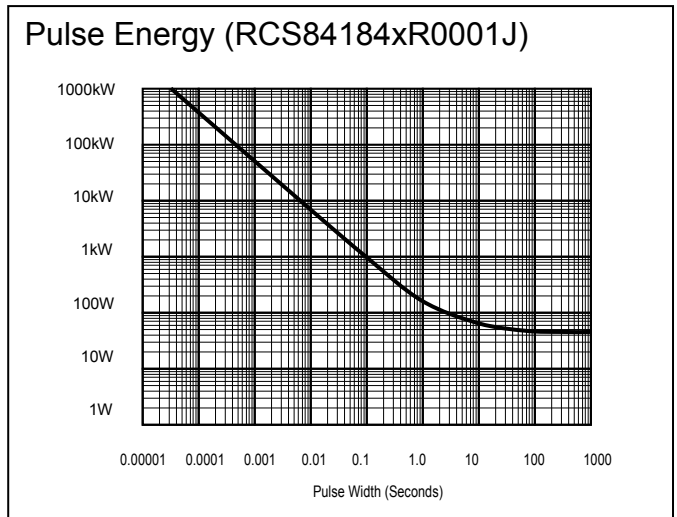
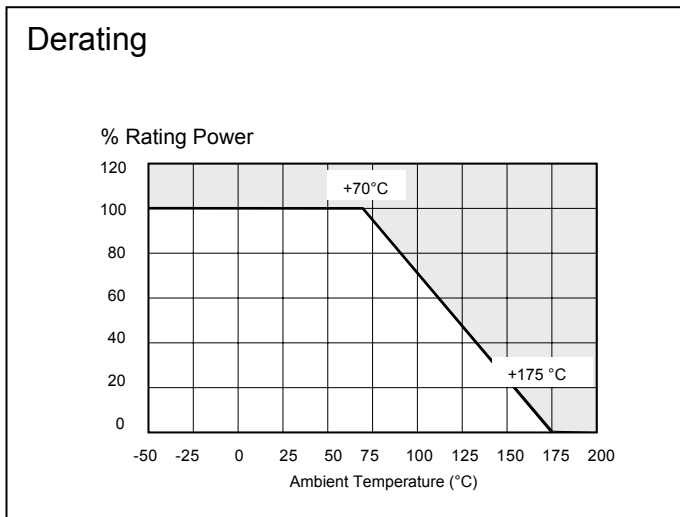

Note

4-TERMINALS MILLIOHM
PRECISION RESISTORS

FHR4-2321



Features and Applications

Milliohm such precision resistor from 0.001Ohm to 50Ohms as resistance tolerance to +/-0.1%, TCR to +/-15ppm/°C, load stability to 0.1% with 40W power rating.

Small size and thin profile produce very low inductance, fit for high / wide frequency operation.

Applications include inverter / converter power electronics, UPS, motor speed control, power device test, circuit board test, LSI test, precision measurements, battery charging for automotive and industrial.

Dimensions (mm)

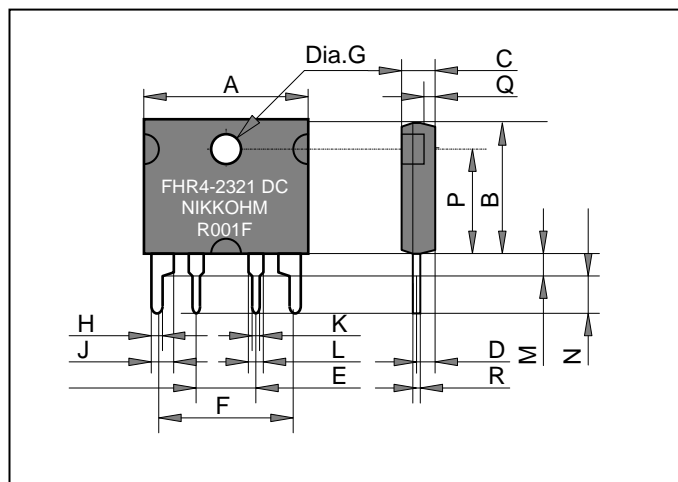

	FHR4-2321
A	22.3 +/-0.2
B	17.25 +/- 0.2
C	4.50 +/-0.1
D	2.10 +/-0.2
E	7.62 +/-0.1
F	17.78 +/-0.1
G	3.20 +/-0.1
H	1.5 +/-0.2
J	3.0 +/-0.2
K	1.1 +/-0.2
L	2.0 +/-0.1
M	3.0 +/-0.2
N	5.0 +/-0.2
P	16.75 +/-0.2
Q	1.5 +/-0.2
R	0.8 +/-0.2

Ordering Information

Model	TCR	Resistance Value	Tolerance	Code	Package
FHR4-2321	E	R005	D(0.5%)	Z00	
FHR4-2321	E (25ppm/°C)	R001- 50R	F(1%), J(5%) (>=0R001) D(0.5%), F(1%), J(5%) (>0R005) B(0.1%), D(0.5%), F(1%), J(5%) (>R010)	Z00	BULK

4-TERMINALS MILLIOHM PRECISION RESISTORS

FHR4-2321

Specifications and Performances

	Specifications	Conditions
Rating Power	40 Watt	Below 50 °C flange temperature.
Rating Power	3 Watt	Free air.
Thermal Resistance,	2.0 °C/W	Resistor-Flange
Max. Operating Current	100 A at 1mΩ	Short time overload, 2.5 seconds.
Resistance Range	0.001 Ω - 50 Ω	
Nominal Resistance	1, 2, 3, 5	
Shelf Life Stability	0.1%, 0.2%, 0.5%	1000hours, depends on stress
TCR, R001 to 100R	+/-25ppm/°C	20°C to 60°C
TCR, Option	+/-15ppm/°C	20°C to 60°C
Insulation Voltage	300VDC	
Maximum Current	150A	
Thermal EMF	< 1uV/° C	
Operation Temp. Range	-40 to +130 deg C	
Resistor Material	Cu-Ni-Mn alloy	Foil
Substrate	Anodized Aluminum	
Housing	Epoxy resin	
Terminals	Tinned Copper	
Terminal Type	Four	
Maximum Torque	0.8 N/m	

Derating

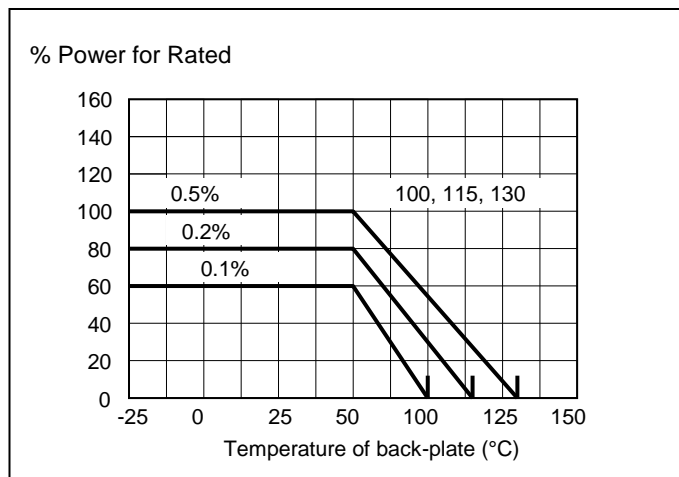

Temperature Coefficient, typical

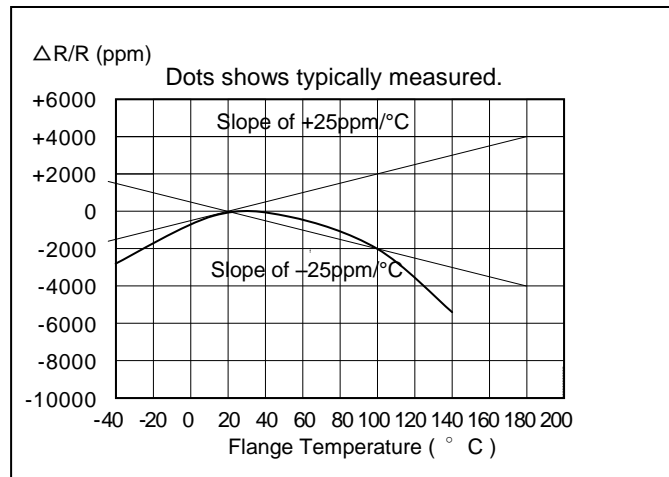

Note.

Note.

4-TERMINALS MILLIOHM
PRECISION RESISTORS

FHR4-3825



Features and Applications

Milliohm such precision resistor from 0.001Ohm to 100Ohms as resistance tolerance to +/-0.1%, TCR to +/-10ppm/°C, load stability to 0.1% with 50W power rating.

Small size and thin profile produce very low inductance, fit for high / wide frequency operation.

Applications include inverter / converter power electronics, UPS, motor speed control, power device test, circuit board test, LSI test, precision measurements, battery charging for automotive and industrial.

Dimensions (mm)

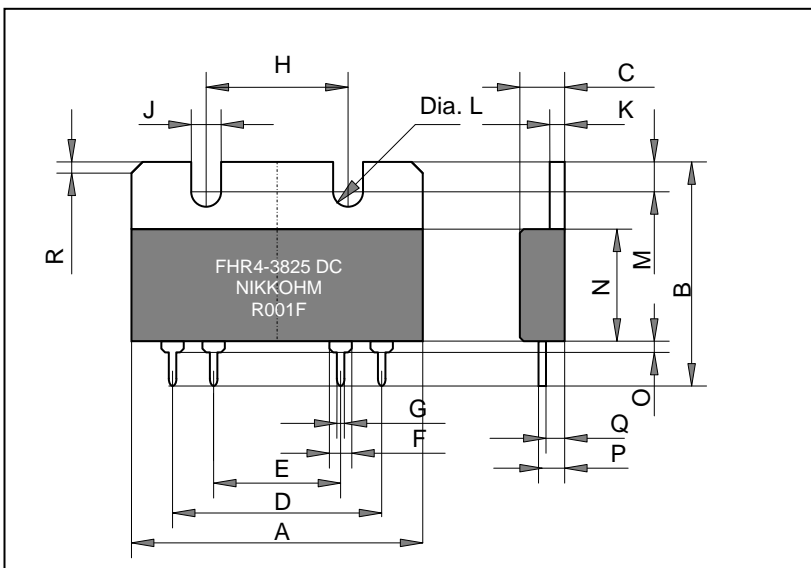

(mm)	FHR4-3825
A	38.0 +/-0.3
B	24.0 +/- 0.2
C	6.0 +/-0.2
D	27.5 +/-0.2
E	17.5 +/-0.2
F	3.00+/-0.1
G	1.5 +/-0.1
H	17.5 +/-0.2
J	3.2+/-0.1
K	2.0 +/-0.1
L	3.20
M	4.0 +/-0.1
N	15.0 +/-0.2
P	3.3 +/-0.2
Q	2.8 +/-0.2
R	1.5 x 45° +/-0.2

Ordering Information

Model	TCR	Resistance Value	Tolerance	Code	Package
FHR4-3825	E	R005	D	Z00	
FHR4-3825	E (25ppm/°C)	R001- 100R	F(1%), J(5%) (>=0R001) D(0.5%), F(1%), J(5%) (>0R005) B(0.1%), D(0.5%), F(1%), J(5%) (>R010)	Z00	BULK

4-TERMINALS MILLIOHM PRECISION RESISTORS

FHR4-3825

Specifications and Performances

	Specifications	Conditions
Rating Power	50 Watt	Below 50 °C flange temperature.
Rating Power	3 Watt	Free air.
Thermal Resistance,	1.6 °C/W	Resistor-Flange
Max. Operating Current	150A or 225 A at 1mΩ	
Resistance Range	0.001 Ω - 50 Ω	
Nominal Resistance	1, 2, 3, 5	
Shelf Life Stability	0.1%, 0.2%, 0.5%	1000hours, depends on stress
TCR, R001 to 100R	+/-25ppm/°C	20°C to 60°C
TCR, Option	+/-10ppm/°C	20°C to 60°C
Insulation Voltage	500VDC	
Maximum Current	150A	
Thermal EMF	< 1uV/° C	
Operation Temp. Range	-40 to +130 deg C	
Resistor Material	Cu-Ni-Mn alloy	Foil
Substrate	Anodized Aluminum	
Housing	Epoxy resin	
Terminals	Tinned Copper	
Terminal Type	Four	
Maximum Torque	1.0 N/m	

Derating

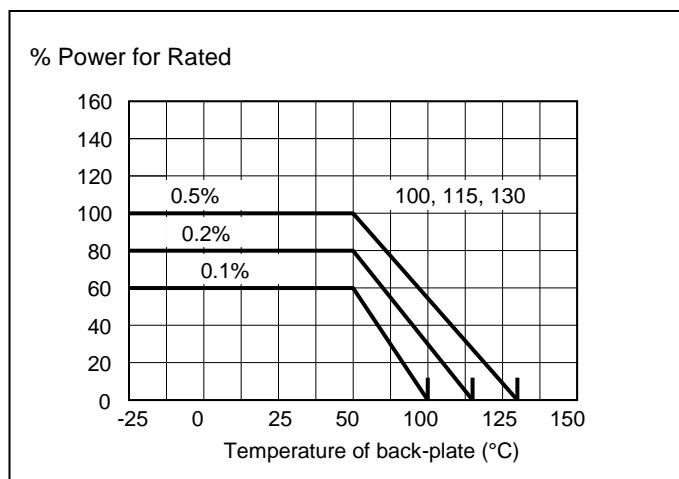

Temperature Coefficient, typical

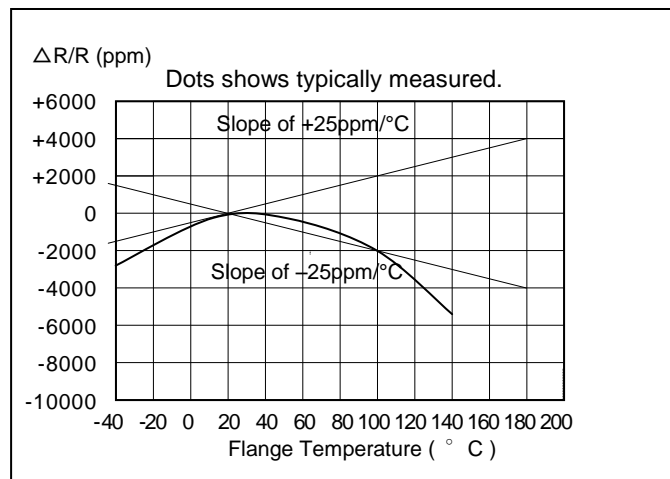

Note.

Note.

PRECISION SCREW MOUNT
CURRENT SHUNT RESISTORS

RCS3825

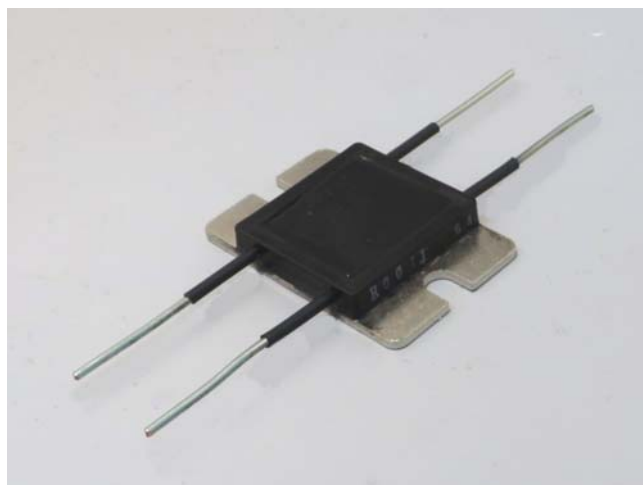

Features and Applications

Rated power 10W, operation current 100A, insulation voltage 2000VAC, four terminals precision shunt resistor.

Tolerance of detecting voltage +/-0.5% and TCR +/-25ppm/°C.

Applications include digital multi-meter, digital power meter, watt-hour meter, power transfer measurement of power electronics.

Dimensions

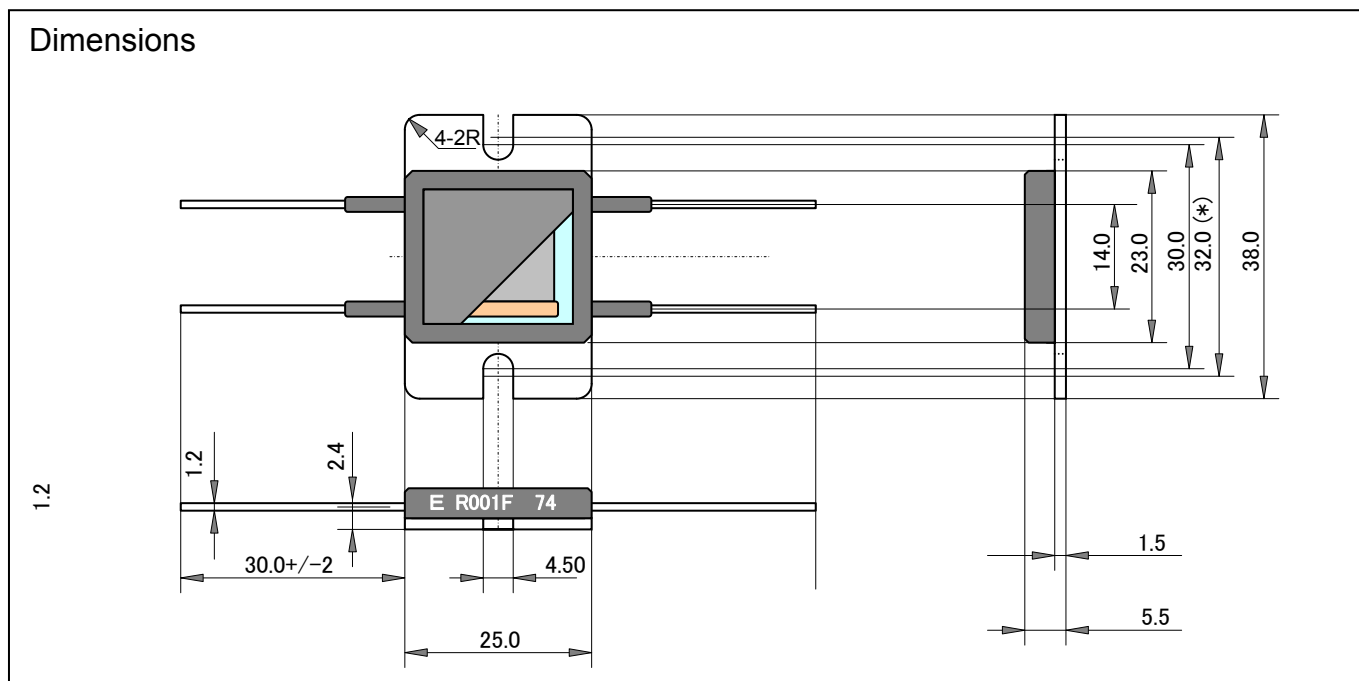

Ordering Information

Type	TCR	Resistance	Tolerance	Code	Note
RCS3825	E	R001	F	Z00	
RCS3825	E (+/-25ppm)	0.2, 0.3, 0.5, 1, 2 mΩ	F (1%)	Z00	RoHS, bulk package

PRECISION SCREW MOUNT CURRENT SHUNT RESISTORS

RCS3825

Specifications and Performances

Items	Specifications	Conditions
Rating Power	10 W	0.2mΩ, at flange temperature -55 to +75 °C
	7 W	0.3mΩ
	6 W	0.5mΩ
	6W	1.0mΩ
	4W	2.0mΩ
Heat Resistance	8.0 °C/W	0.2mΩ, from resistor to flange
Resistance Range	0.2mΩ – 2mΩ	Less than 0.1 Ω option
Nominal Resistance	0.2, 0.3, 0.5, 1. 2 mΩ	
TCR	+/-25 ppm/K (E)	For -55 to +120 °C
Tolerance	+/-1.0%	+/-1.0%
Operation Temp.	-55 to +125 °C	At resistor element surface
Max. Applied Voltage	$E = \sqrt{P \cdot R}$	
Withstanding Voltage	2000 VAC	60 seconds between terminals and flange. Leak current below 0.5mA
Load Life	dR+/-1.0 %	Continuous power 1000hours.
Humidity	dR+/-1.0 %	60 °C, 90 to 95%RH, DC0.1W, 1000hours.
Temperature Cycle	dR+/-1.0 %	-55 °C, 30 min., +155 °C 30min., 5 cycles.
Insulation Resistance	Over 1000 Meg ohm	Between terminals and flange.
Vibration	dR+/-0.5 %	Note 2
Flammability	UL94V-0	For resistor body
Weight	20 grams	May be changed by lead length.

Note 1: Torque: Terminal 1.0Nm max, 0.6Nm recommend. Mounting 1.6Nm max, 1.0Nm recommend.

Note 2: IEC60068-2-6, displacement 0.75mm or acceleration 100m/sec², 10Hz-54Hz sweep, 10 cycles X-Y-Z direction.

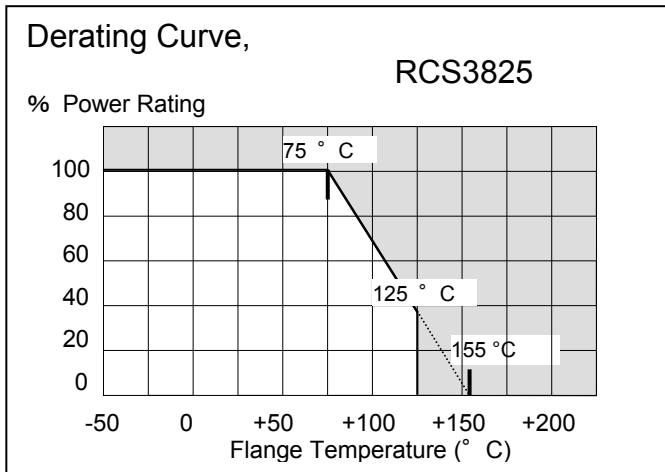

Materials

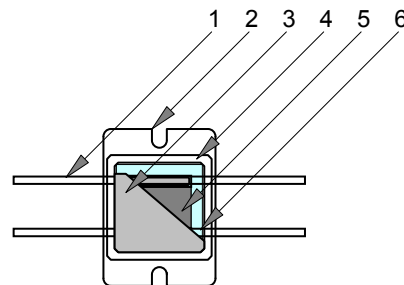

1	Terminals	1.2mmtin plated copper wire
2	Flange	Ni plated copper plate
3	Molding	Epoxy resin
4	Resin frame	Glass filled PA6
5	Resistor	Metal plate
6	Insulator	ALO

Applications

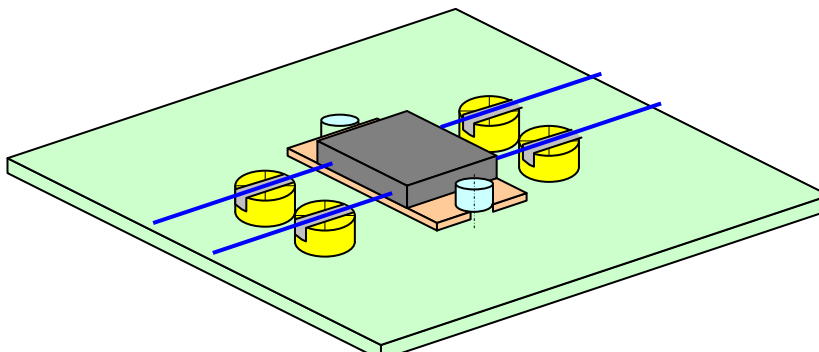

20170601

RF CURRENT DETECT RESISTORS

RAF30

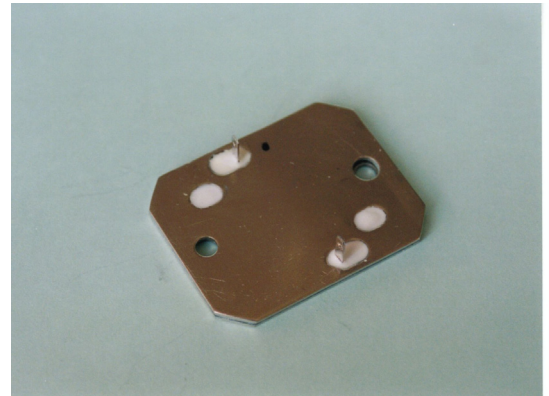

Features and Applications

1milliohm to 5milliohm, 30W rating power, Kelvin 4 terminal, bus-bar attachment type, precision current detector.

Inductance influence has been decreased through the small distance between current terminals.

Applications include industrial measurement, measuring instruments, precision power supply, precision equipment power supply, constant current power supply, IC test equipment, ac motor control, actuator control, inverters, IPM, rechargeable battery charge circuits, etc.

Dimensions (mm)

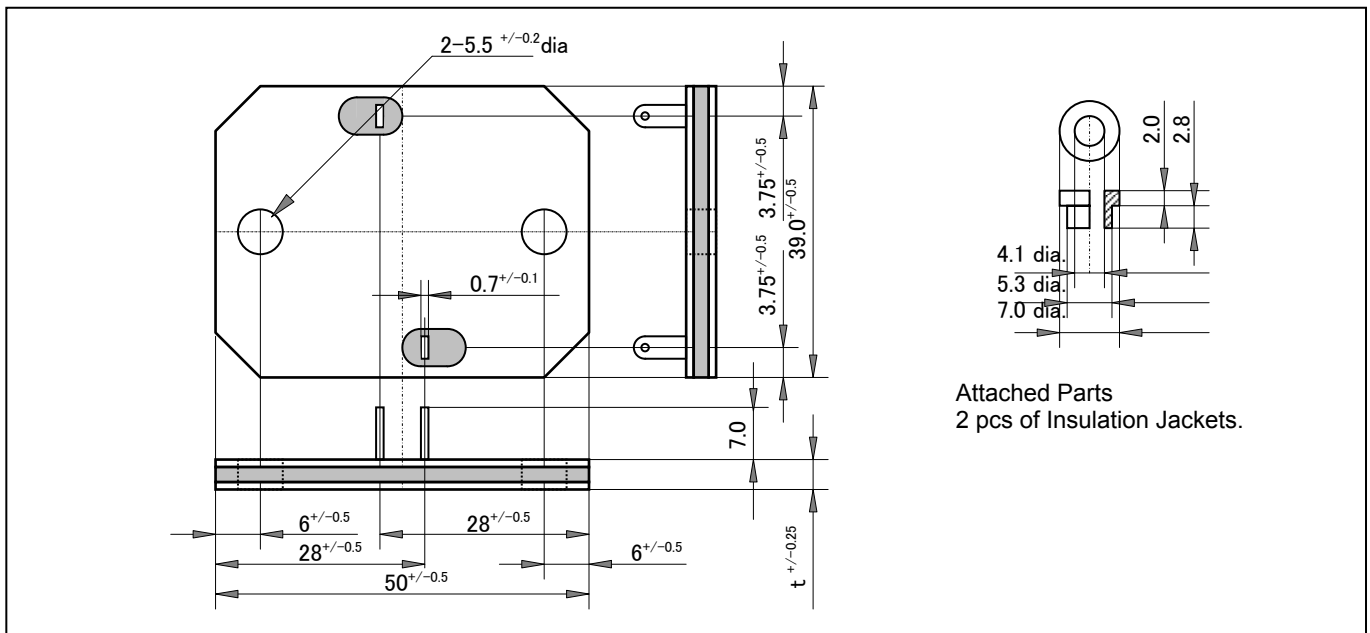

Notes: Thickness, $t=2.7\text{mm}$ (at 1milliohm), $t=2.4\text{mm}$ (at 2milliohm), $t=2.3\text{mm}$ (at 4milliohm)

Ordering Information

Type	TCR	Resistance	Tolerance	Code	Note
RAF30	C	0R001	F (1%)	000	
RAF30	C (50ppm/C)	0R001	F (1.0 %)	000	Not RoHS
	E (25ppm/C)	0R002	D (0.5 %)		
		0R003			
		0R004			
		0R005			

RF CURRENT DETECT RESISTORS

RAF30

Specifications

	Specifications	Conditions
Power Rating	30W with heat sink (Bus Bar)	
Rating Temperature	-55 to +125 degree C	
Resistance	1milliohm to 5milliohms	
Tolerance	+/-0.5%(D), +/-1.0%(F),	
TCR	+/-50ppm/K (C), +/-25ppm/K (E)	
Thermal EMF	Less than 1micro Volts in 0 -100 degree C.	
Operating Temperature	-55 to +125 degree C	
Weight	38 grams	

Typical Installation and Circuit

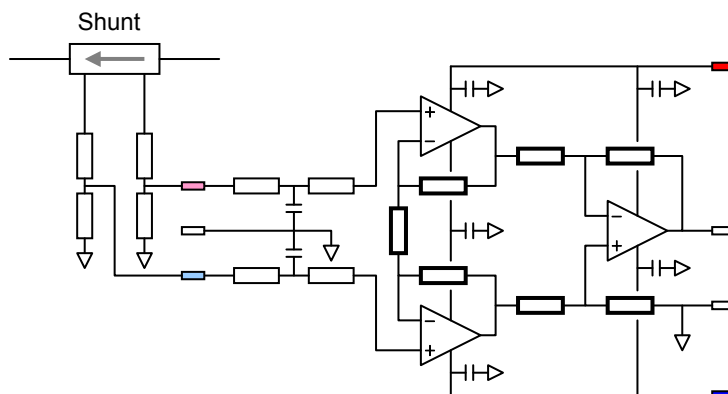
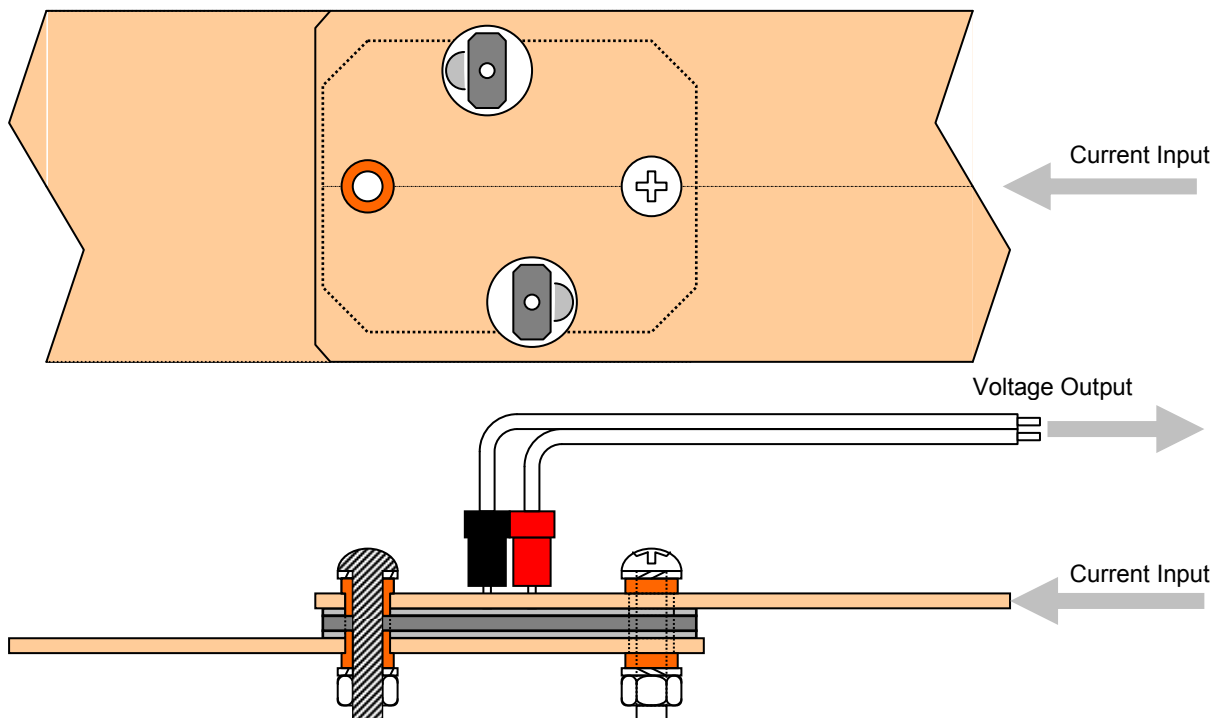

20110501

PRECISION CURRENT SHUNT RESISTORS

RSN



Features and Applications

1A-50mV to 500A-50mv, 1A-100mV to 500A-100mV, +/-0.1% shunt resistors for power electric equipment and measurements.

Manganin alloys produce excellent TCR and low emf.

Easy current measurement is performed by attaching to current bus or wires and connecting to ampere-meter through flexible wires.

All of shunts are calibrated on equipment with current certifications traceable to US-N.I.S.T

For high precision power supply, power converters, and current measurement instruments.

Dimensions (mm)

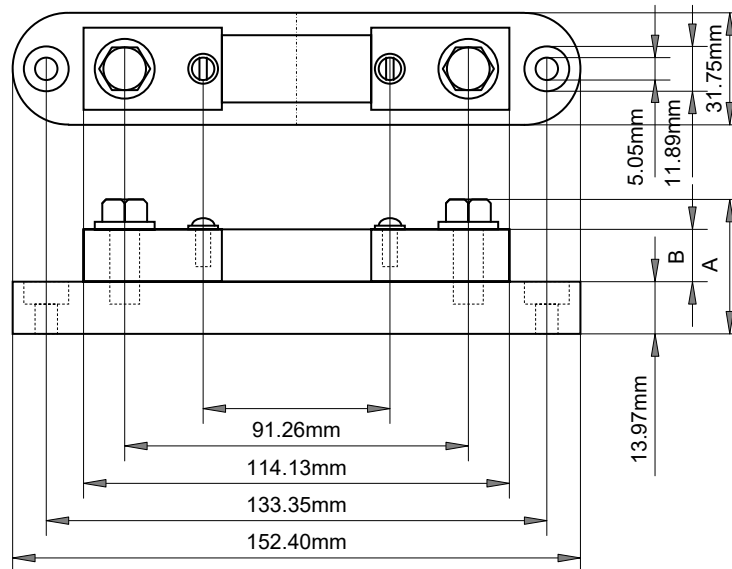

50mV MODEL	A	B
RSN-1-50	35.05	12.7
RSN-2-50	35.05	12.7
RSN-5-50	35.05	12.7
RSN-10-50	35.05	12.7
RSN-20-50	35.05	12.7
RSN-50-50	35.05	12.7
RSN-100-50	35.05	12.7
RSN-150-50	35.05	12.7
RSN-200-50	35.05	12.7
RSN-250-50	41.40	19.05
RSN-300-50	41.40	19.05
RSN-400-50	41.40	19.05
RSN-500-50	41.40	19.05

100mV MODEL	A	B
RSN-1-100	35.05	12.7
RSN-2-100	35.05	12.7
RSN-5-100	35.05	12.7
RSN-10-100	35.05	12.7
RSN-20-100	35.05	12.7
RSN-50-100	35.05	12.7
RSN-100-100	35.05	12.7
RSN-150-100	35.05	12.7
RSN-200-100	35.05	12.7
RSN-250-100	35.05	12.7
RSN-300-100	35.05	12.7
RSN-400-100	41.40	19.05
RSN-500-100	41.40	19.05

PRECISION CURRENT SHUNT RESISTORS

RSN

Ordering Information

Model	Rating Current in A	Voltage in mV	Tolerance	Code
RSN	-200	-50mV	B	Z00
RSN	1 - 500 (1)	-50mV -100mV	B (+/-0.1%)	Z00

(1) Recommended operation current shall be 2/3 of their rated current.

Specifications

Specifications				
Model	Rated Current (A)	Operating Current (A)	Resistance (mΩ) 50mV Output	Resistance (mΩ) 100mV Output
RSN-1	1	0.667	50	100
RSN-2	2	1.33	25	50
RSN-5	5	3.33	10	20
RSN-10	10	6.67	5.0	10
RSN-20	20	13.33	2.5	5.0
RSN-50	50	33.33	1.0	2.0
RSN-100	100	66.67	0.5	1.0
RSN-150	150	100	0.333	0.667
RSN-200	200	133.33	0.25	0.50
RSN-250	250	166.67	0.20	0.40
RSN-300	300	200	0.167	0.333
RSN-400	400	266.67	0.125	0.25
RSN-500	500	333.33	0.10	0.20

Specifications

	Specifications
Rated Output	50mV, 100mV, Custom
Voltage Tolerance	+/-0.1%
Operating Temp.	30°C to 70°C
Storage Temp.	-55°C to 80°C
Materials	Resistance: Manganin Terminal Block: Brass Base: Phenol Resin

Manganin Temperature Coefficient of Resistance +/-15ppm/°C

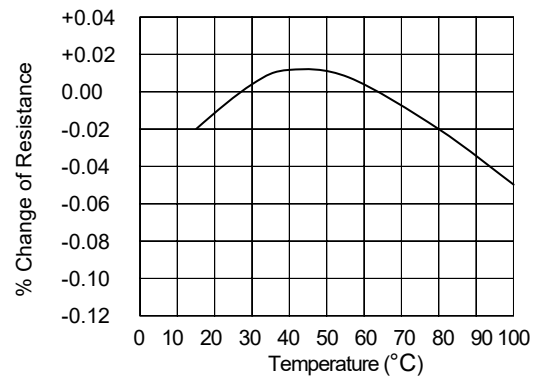

Operating Current Derating: For continuous operation, it is recommended that shunts are not run at more than two third (2/3) the rated current under normal conditions per IEEE standard of DC instrument shunts. At ambient temperature above 40 C, the current must be further derated to prevent damage.

20170301

LIGHTWEIGHT PRECISION
CURRENT SHUNT RESISTORS

NSLA10, NSLA20, NSLA30
NSLA50, NSLA75, NSLA80
NSLA85, NSLA100, NSLA150



Features and Applications

Lightweight large current shunt resistors for ampere-meters, designed for power electric equipment. Excellent long-term stability, low emf and low TCR.

Easy current measurement is performed by attaching to current bus or wires and connecting to ampere-meter through flexible wires.

All of shunts are calibrated on equipment with current certifications traceable to US-N.I.S.T For high precision power supply, power converters, and current measurement instruments.

Dimension (mm)

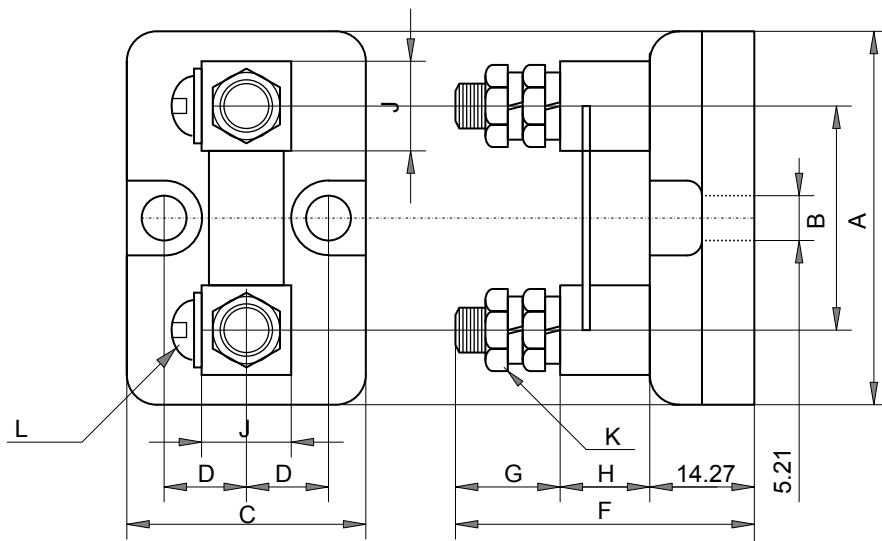

mm	NSLA10 -50	NSLA15 -50	NSLA20 -50	NSLA30 -50	NSLA50 -50	NSLA75 -50	NSLA80 -50	NSLA85 -50	NSLA100 -50	NSLA150 -50
A	50.80 mm									
B	25.40 mm									
C	31.75 mm									
D	11.10 mm									
F	42.88 mm									
G	15.88 mm									
H	12.70 mm									
J	13.0mm x 13.0mm									
K (inch)	1/4-28 (6.0mm)									
L (inch)	0.36L-10-32 scr. (4.0mm-9mm)									

Tolerances +/-0.015 inch (+/-0.38 mm) for hole diameter, Other tolerances +/-0.030 inch (+/- 0.076 mm) unless otherwise noted.

LIGHTWEIGHT PRECISION CURRENT SHUNT RESISTORS

NSLA10, NSLA20, NSLA30, NSLA50, NSLA75, NSLA80 NSLA85, NSLA100, NSLA150

Ordering Information

Style	Rating Current in A	Voltage in mV	Tolerance	Code
NSLA	10	-50mV	C	Z00
NSLA	15	-50mV	C(+/-0.25%)	Z00
	20	-60mV		
	30			
	50			
	75			
	80			
	85			
	100			
	150			

(1)

- (1) Accuracy will be assure B (+/-0.1%) in option.
 (2) Recommended operation current shall be 2/3 of their rated current.

Specification and Performance

	NSLA10	NSLA15	NSLA20	NSLA30	NSLA50	NSLA75	NSLA80	NSLA85	NSLA100	NSLA150
Rated Current (A)	10	15	20	30	50	75	80	85	100	150
Operating Current (A)	6.67	10.00	13.33	20.00	33.33	50.00	53.33	56.67	66.67	100.00
Net Weight (g)	90	90	90	90	90	90	90	90	90	90
Rated Output (mV)	50, 60									
Resistance (milliohms)	Resistance is based on the amperage and mV rating, nominal resistance is calculated using Ohms law.									
Voltage Tolerance (%)	+/-0.25%(C)									
Operating Temp.	+30 to +70 deg C measured at center of manganin strips									
Storage Temp.	-55 to +80 deg C									

The way to reduce the operating temperature, such as forced air, increasing physical size, adding heat sink to the blocks, designing for water cooling, and etc.

	50mV
NSLA10-50	5.00000 milliohm
NSLA15-50	3.33333 milliohm
NSLA20-50	2.50000 milliohm
NSLA30-50	1.66667 milliohm
NSLA50-50	1.00000 milliohm
NSLA75-50	0.66667 milliohm
NSLA80-50	0.62500 milliohm
NSLA85-50	0.58824 milliohm
NSLA100-50	0.50000 milliohm
NSLA150-50	0.33333 milliohm
	60mV
NSLA10-60	6.00000 milliohm
NSLA15-60	4.00000 milliohm
NSLA20-60	3.00000 milliohm
NSLA30-60	2.00000 milliohm
NSLA50-60	1.20000 milliohm
NSLA75-60	0.80000 milliohm
NSLA80-60	0.75000 milliohm
NSLA85-60	0.70588 milliohm
NSLA100-60	0.60000 milliohm
NSLA150-60	0.40000 milliohm

Equivalent resistance (milliohm) calculated from the I-V characteristic.

Thickness (mm)	Width (mm)	Current (A) at 30 deg C Temp. Rise	Current (A) at 65 deg C temp. Rise
3	25	230	362
4	25	290	456
4	50	510	802
5	25	340	535
5	50	610	960
6	25	380	598
6	30	430	675
6	40	550	865
6	50	680	1070
6	75	940	1479
6	100	1200	1888
6	125	1440	2265
6	150	1680	2643
8	50	800	1258
8	75	1100	1730
8	100	1400	2202
8	125	1650	2595
8	150	1930	3036
10	50	880	1384
10	75	1220	1919
10	100	1540	2422

Current capacity of copper bus bar, JSIA

LIGHTWEIGHT PRECISION CURRENT SHUNT RESISTORS

NSLA10, NSLA20, NSLA30, NSLA50, NSLA75, NSLA80
 NSLA85, NSLA100, NSLA150

Applications

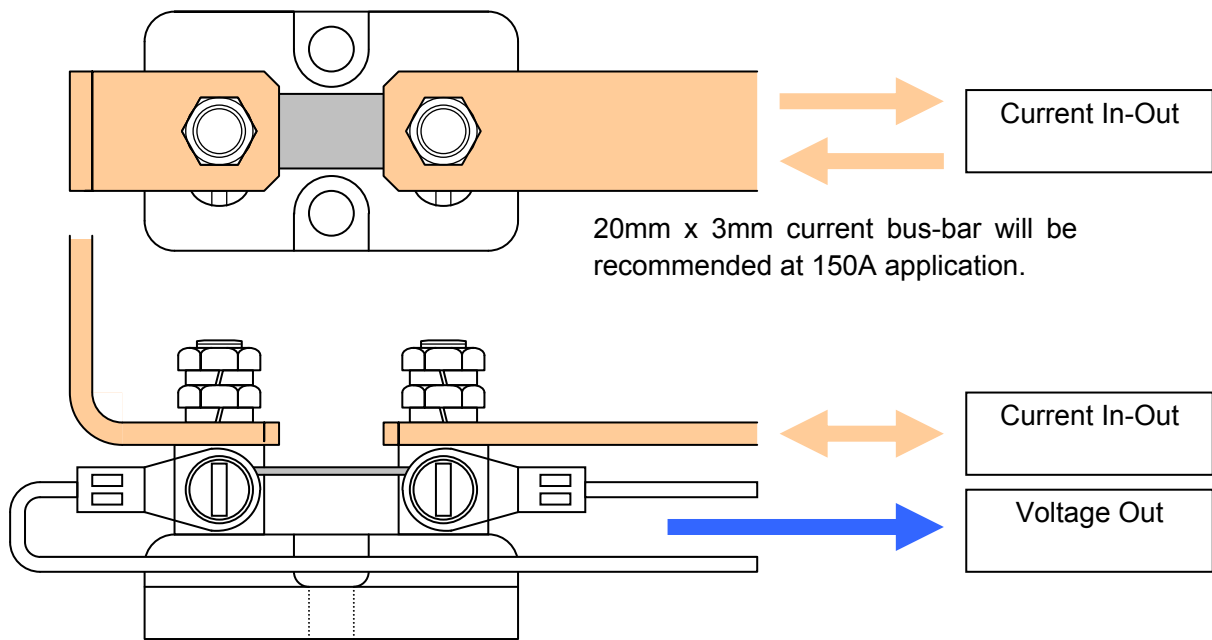

NSLA10-60mV



NSLA50-60mV



NSLA100-60mV



NSLA150-60mV

Note
 The resistance will remain within 0.25% if the shunt is operated between 20 and 90 degrees C. If the temperature of the shunt exceeds 90 degrees C the resistance may drift. The temperature of the shunt is measured on the resistance strips.

LIGHTWEIGHT PRECISION
CURRENT SHUNT RESISTORS

NSLB170, NSLB200, NSLB250
NSLB300, NSLB400, NSLB450
NSLB500, NSLB600



Features and Applications

Lightweight large current shunt resistors for ampere-meters, designed for power electric equipment.

Excellent long-term stability, low emf and low TCR.

Easy current measurement is performed by attaching to current bus or wires and connecting to ampere-meter through flexible wires.

All of shunts are calibrated on equipment with current certifications traceable to US-N.I.S.T

For high precision power supply, power converters, and current measurement instruments.

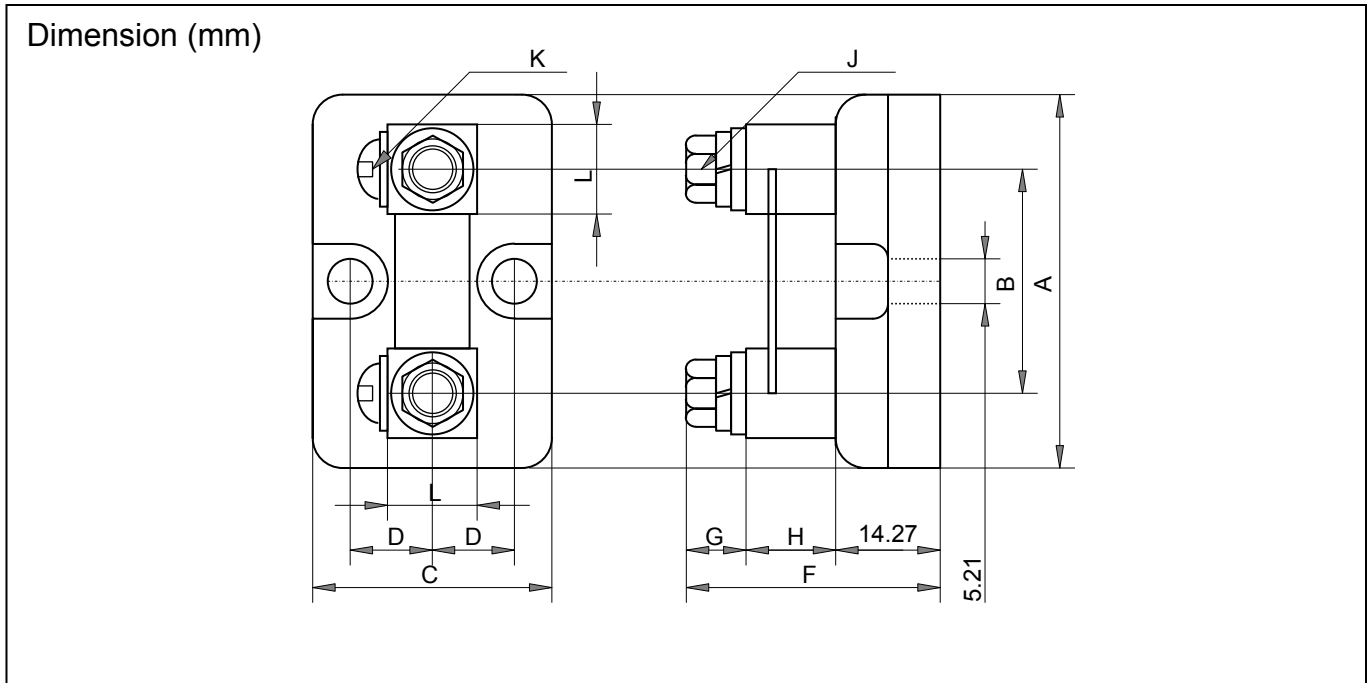

p/n	A	B	C	D	F	G	H	J (inch)	K (inch)
NSLB170-50	82.55	38.10	44.45	15.88	44.45	11.13	19.05	1/8-16x5/8	#10-32 SCR.
NSLB200-50	82.55	38.10	44.45	15.88	44.45	11.13	19.05	1/8-16x5/8	#10-32 SCR.
NSLB250-50	82.55	38.10	44.45	15.88	44.45	11.13	19.05	1/8-16x5/8	#10-32 SCR.
NSLB300-50	82.55	38.10	44.45	15.88	44.45	11.13	19.05	1/8-16x5/8	#10-32 SCR.
NSLB400-50	82.55	38.10	44.45	15.88	44.45	11.13	19.05	1/8-16x5/8	#10-32 SCR.
NSLB450-50	82.55	38.10	44.45	15.88	44.45	11.13	19.05	1/8-16x5/8	#10-32 SCR.
NSLB500-50	82.55	38.10	44.45	15.88	44.45	11.13	19.05	1/8-16x5/8	#10-32 SCR.
NSLB600-50	82.55	38.10	44.45	15.88	44.45	11.13	19.05	1/8-16x5/8	#10-32 SCR.

Tolerances +/-0.015 inch (+/-0.38 mm) for hole diameter, Other tolerances +/-0.030 inch (+/- 0.076 mm) unless otherwise noted.

LIGHTWEIGHT PRECISION CURRENT SHUNT RESISTORS

NSLB170, NSLB200, NSLB250, NSLB300, NSLB400, NSLB450
NSLB500, NSLB600

Ordering Information

Style NSLB	Rating Current in A 200	Voltage in mV -50mV	Tolerance C	Code Z00
NSLB	170 200 250 300 400 450 500 600	-50mV	C (+/-0.25%)	Z00

(1)

- (1) Accuracy will be assure B (+/-0.1%) in option.
- (2) Recommended operation current shall be 2/3 of their rated current.

Specification and Performance

	NSLB170	NSLB200	NSLB250	NSLB300	NSLB400	NSLB450	NSLB500	NSLB600
Rated Current (A)	170	200	250	300	400	450	500	600
Operating Current (A)	113	133	166	200	267	300	333	400
Net Weight (g)	---	---	---	---	---	---	---	---
Rated Output	50mV or 60mV							
Resistance (milliohms)	Resistance is based on the amperage and mV rating, nominal resistance is calculated using Ohms law.							
Voltage Tolerance (%)	+/-0.25%(C)							
Operating Temp.	+30 to +70 deg C measured at center of manganin strips							
Storage Temp.	-55 to +80 deg C							

The way to reduce the operating temperature, such as forced air, increasing physical size, adding heat sink to the blocks, designing for water cooling, and etc.

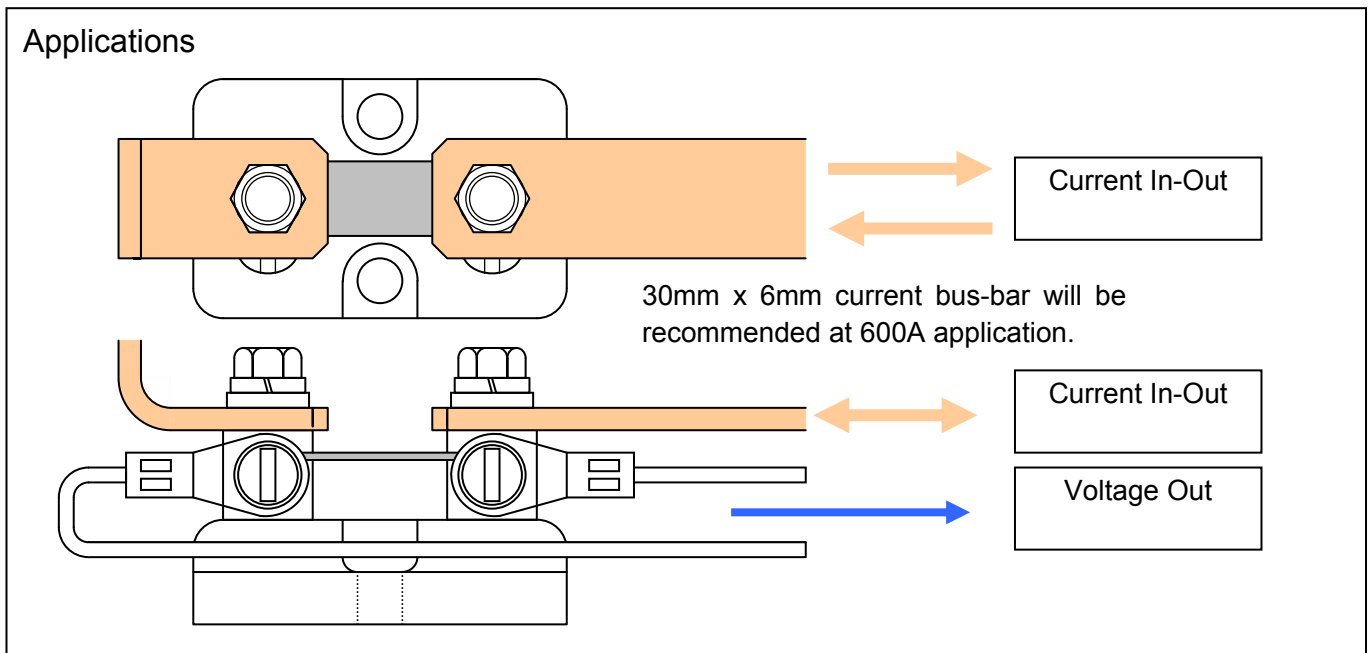

20120101

LIGHTWEIGHT PRECISION
CURRENT SHUNT RESISTORS

NSLC800, NSLC1000, NSLC1200



Features and Applications

Lightweight large current shunt resistors for ampere-meters, designed for power electric equipment.

Excellent long-term stability, low emf and low TCR.

Easy current measurement is performed by attaching to current bus or wires and connecting to ampere-meter through flexible wires.

All of shunts are calibrated on equipment with current certifications traceable to US-N.I.S.T

For high precision power supply, power converters, and current measurement instruments.

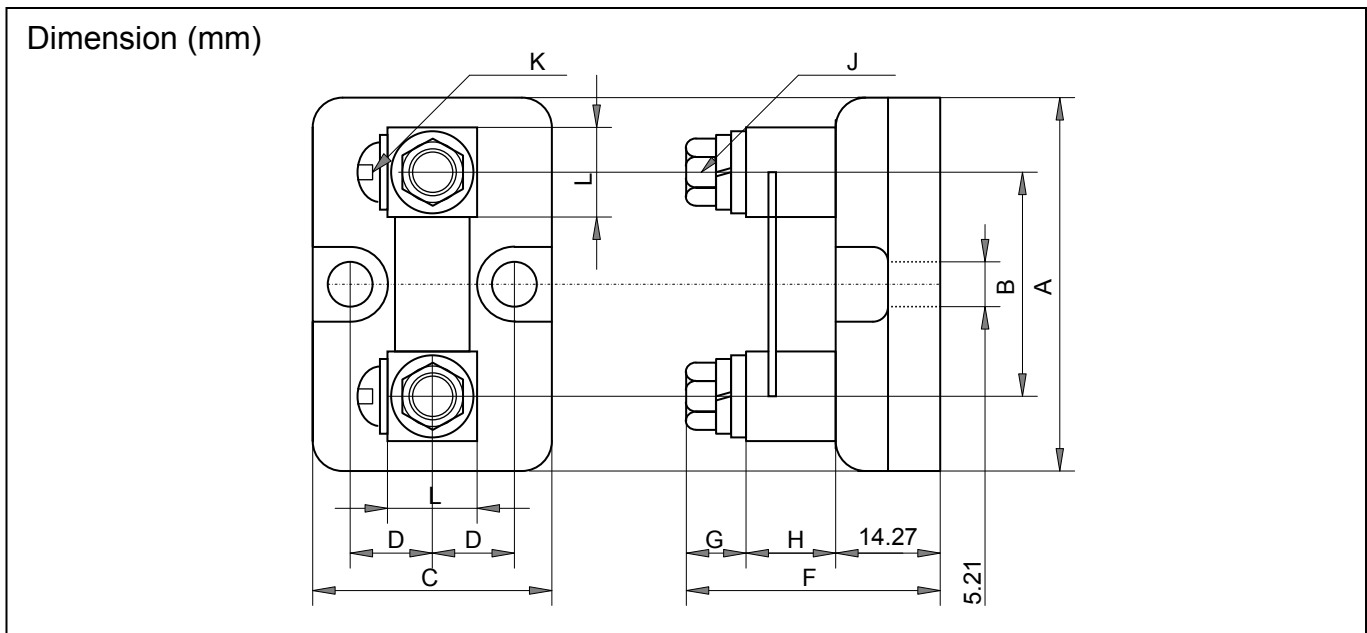

p/n	A	B	C	D	F	G	H	J	K
NSLC800-50	114.30	54.86	63.50	25.40	53.98	14.27	25.40	1/2-13x7/8	#10-32 SCR.
NSLC1000-50	114.30	54.86	63.50	25.40	53.98	14.27	25.40	1/2-13x7/8	#10-32 SCR.
NSLC1200-50	114.30	54.86	63.50	25.40	53.98	14.27	25.40	1/2-13x7/8	#10-32 SCR.

Tolerances +/-0.015 inch (+/-0.38 mm) for hole diameter, Other tolerances +/-0.030 inch (+/- 0.076 mm) unless otherwise noted.

Ordering Information

Style	Rating Current in A	Voltage in mV	Tolerance	Code
NSLC	1000	-50mV	C	Z00
NSLC	800	-50mV	C(0.25%)	Z00
	1000			
	1200			

- (1) Accuracy will be assure B (+/-0.1%) in option.
- (2) Recommended operation current shall be 2/3 of their rated current.

LIGHTWEIGHT PRECISION CURRENT SHUNT RESISTORS

NSLC800, NSLC1000, NSLC1200

Specification and Performance

	NSLC800	NSLC1000	NSLC1200
Rated Current (A)	800	1000	1200
Operating Current (A)	533	667	800
Net Weight (g)	900	900	900
Rated Output	50mV or 60mV		
Resistance (milliohms)	Resistance is based on the amperage and mV rating, nominal resistance is calculated using Ohms law.		
Voltage Tolerance (%)	+/-0.25%(C)		
Operating Temp.	+30 to +70 deg C measured at center of manganin strips		
Storage Temp.	-55 to +80 deg C		

The way to reduce the operating temperature, such as forced air, increasing physical size, adding heat sink to the blocks, designing for water cooling, and etc.

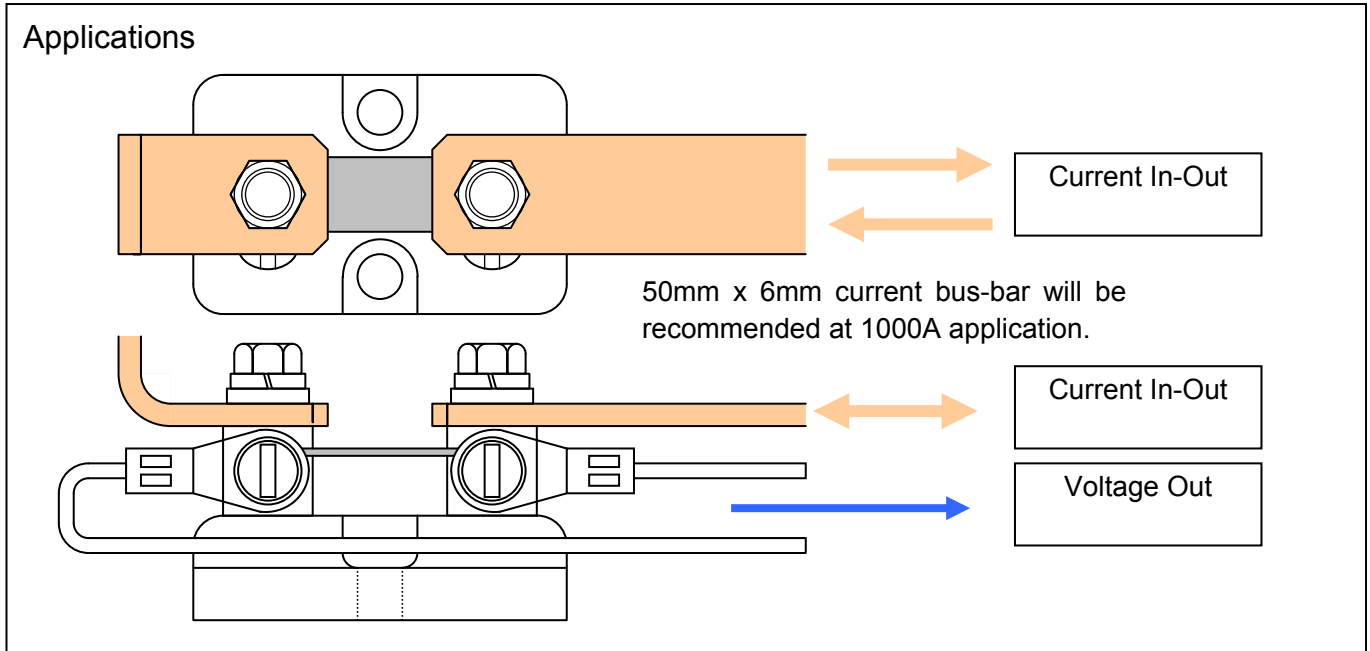

Allowable Current of Cu Bus-Bar (Temperature Rise - A)

Temp rise	3X25	4X25	4X50	5X25	5X50	6X25	6X30	6X40	6X50	6X75	6X100	6X125	6X150	---
30deg C	230	290	510	340	610	380	430	550	680	940	1,200	1,440	1,680	---
65deg C	362	456	802	535	960	598	676	865	1,070	1,479	1,888	2,265	2,643	---

Temp rise	8X50	8X75	8X100	8X125	8X150	10X50	10X75	10X100	10X125	10X150	12X75	12X100	12X125	12X150
30deg C	800	1,100	1,440	1,650	1,930	880	1,220	1,540	1,820	2,120	1,320	1,660	1,950	2,280
65deg C	1,258	1,730	2,202	2,595	3,036	1,384	1,919	2,422	2,863	3,335	2,076	2,611	3,067	3,586

Allowable Current of Cu Twisted Wire (ambient temperature - A)

sq mm	2	4	6	8	14	22	38	60	100	150	200	250	325	400	500
30 deg C	32	45	59	74	107	140	197	264	363	481	572	678	793	908	1,027
40 deg C	29	39	52	65	95	124	174	234	321	426	506	600	702	804	909
50 deg C	24	33	44	55	80	104	147	198	272	360	428	507	593	680	768

PRECISION CURRENT SHUNT RESISTORS

NSA50, NSA100, NSA150
 NSA200, NSA250, NSA300
 NSA400, NSA500, NSA600

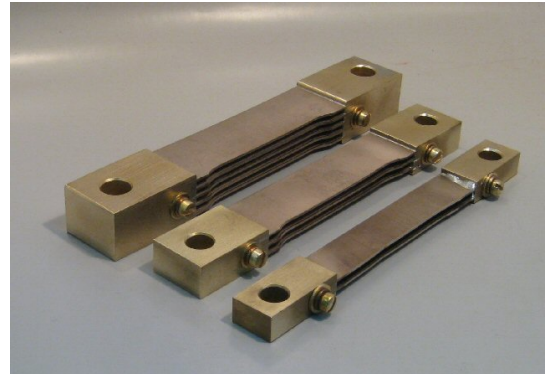

Features and Applications

- Large current shunt resistors for ampere-meters, designed for standard current measurement of electric equipment.
- Excellent long-term stability, low emf and low TCR.
- Easy current measurement is performed by attaching to current bus directory and connecting to ampere-meter through flexible wires.
- All of shunts are calibrated on equipment with current certifications traceable to US-N.I.S.T
- For high precision power supply, power converters, and current measurement instruments.

Dimension (mm)

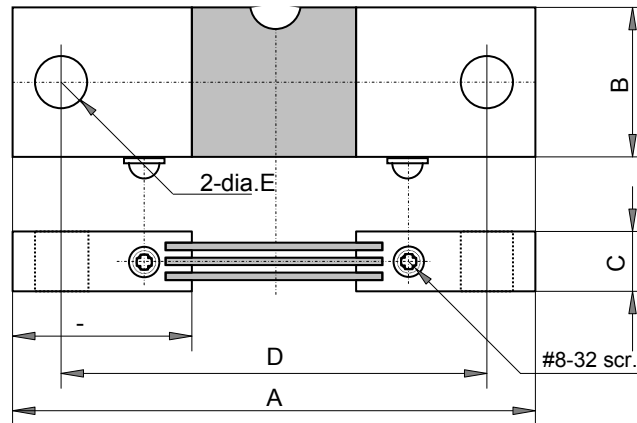

mm	NSA50 -50	NSA100 -50	NSA150 -50	NSA200 -50	NSA250 -50	NSA300 -50	NSA400 -50	NSA500 -50	NSA600 -50
A	104.78	104.78	104.78	104.78	104.78	104.78	117.48	117.48	117.48
B	15.88	15.88	23.83	20.65	27.00	31.75	25.40	31.75	38.10
C	9.53	9.53	9.53	12.70	12.70	12.70	19.05	19.05	19.05
D	84.15	84.15	84.15	84.15	84.15	84.15	92.08	92.08	92.08
E	8.74	8.74	8.74	8.74	8.74	8.74	10.31	10.31	10.31
Ohm	1.000	0.500	0.333	0.250	0.200	0.167	0.125	0.100	0.083

Ohm Resistance (milliohm) calculated from the V-I characteristic

mm	NSA50 -100	NSA100 -100	NSA150 -100	NSA200 -100	NSA250 -100	NSA300 -100	NSA400 -100	NSA500 -100	NSA600 -100
A	146.05	146.05	146.05	146.05	146.05	146.05	158.75	158.75	158.75
B	15.88	15.88	23.83	20.65	27.00	31.75	25.40	31.75	38.10
C	9.53	9.53	9.53	12.70	12.70	12.70	19.05	19.05	19.05
D	125.43	125.43	125.43	125.43	125.43	125.43	134.95	134.95	134.95
E	8.74	8.74	8.74	8.74	8.74	8.74	10.31	10.31	10.31
Ohm	2.000	1.000	0.667	0.500	0.400	0.333	0.250	0.200	0.167

Ohm Resistance (milliohm) calculated from the V-I characteristic.

PRECISION CURRENT SHUNT RESISTORS

NSA50, NSA100, NSA150, NSA200, NSA250, NSA300 NSA400, NSA500, NSA600

Ordering Information

Style	Rated Current in A	Voltage in mV	Tolerance	Code
NSA	300	-50	C	Z00
NSA	50	-50	C(+/-0.25%)	Z00
	100	-60	(1)	
	150	-100		
	200			
	250			
	300			
	400			
	500			
	600			

- (1) Accuracy will be assure B(+/-0.1%) in option.
- (2) Recommended operation current shall be 2/3 of their rated current.

Specification and Performance

	NSA50	NSA100	NSA150	NSA200	NSA250	NSA300	NSA400	NSA500	NSA600
Rated Current (A)	50	100	150	200	250	300	400	500	600
Operating Current (A)	33.3	66.7	100	133	167	200	267	333	400
Rated Output (mV)	50, 60 or 100								
Eq. Resistance(milliohms)	Resistance is based on the amperage and millivolt rating, nominal resistance is calculated using Ohms law.								
Voltage Tolerance (%)	+/-0.25%(C)								
Operating Temp. (deg C)	+30 to +70 deg C measured at center of manganin strips								
Strage Temp. (deg C)	-55 to +80 deg C								
Weight (Kg)									

The way to reduce the operating temperature, such as forced air, increasing physical size, adding heat sink to the blocks, designing for water cooling, and etc.

Thickness (mm)	Width (mm)	Current (A) at 30 deg C Temp. Rise	Current (A) at 65 deg C temp. Rise
3	25	230	362
4	25	290	456
4	50	510	802
5	25	340	535
5	50	610	960
6	25	380	598
6	30	430	675
6	40	550	865
6	50	680	1070
6	75	940	1479
6	100	1200	1888
6	125	1440	2265
6	150	1680	2643
8	50	800	1258
8	75	1100	1730
8	100	1400	2202
8	125	1650	2595
8	150	1930	3036
10	50	880	1384
10	75	1220	1919
10	100	1540	2422

Current capacity of copper bus bar, JSIA

PRECISION CURRENT SHUNT RESISTORS
NSA50, NSA100, NSA150, NSA200, NSA250, NSA300
NSA400, NSA500, NSA600

TCR Characteristics, Typical

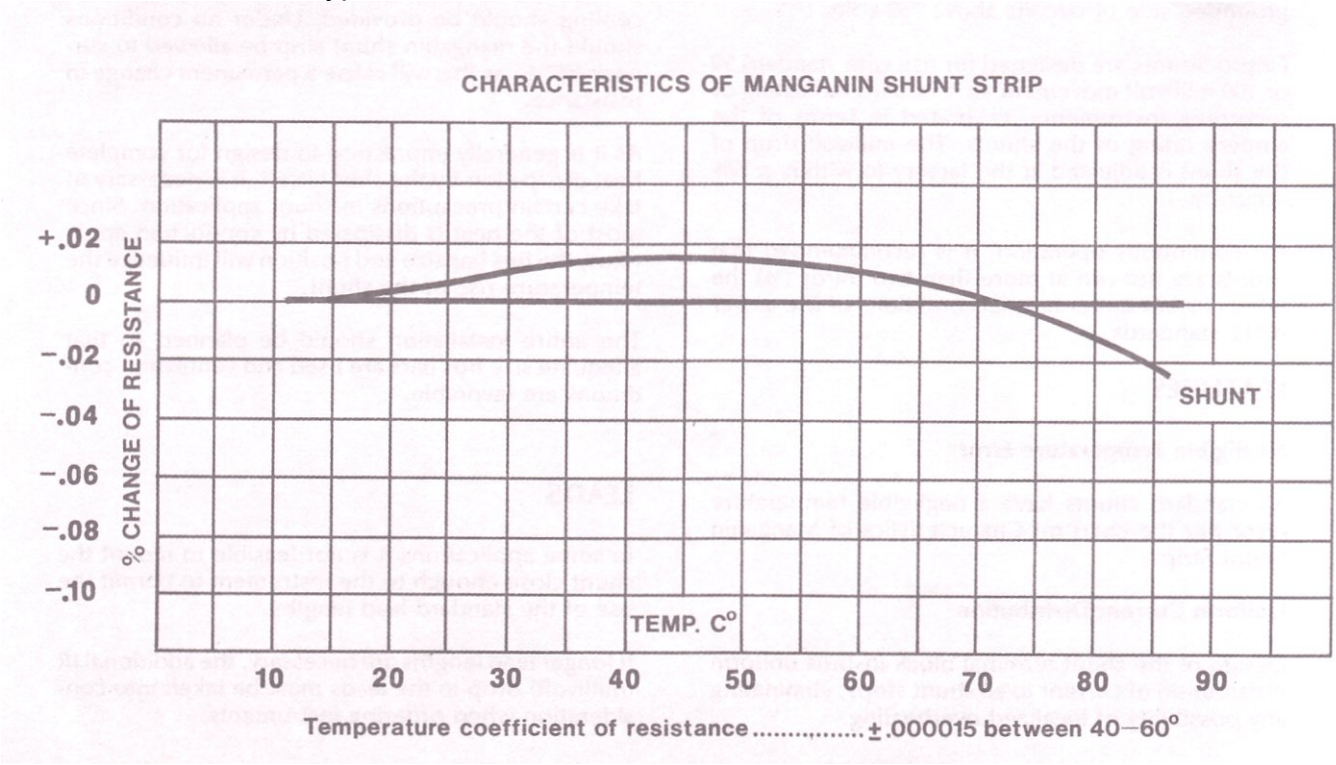

Applications

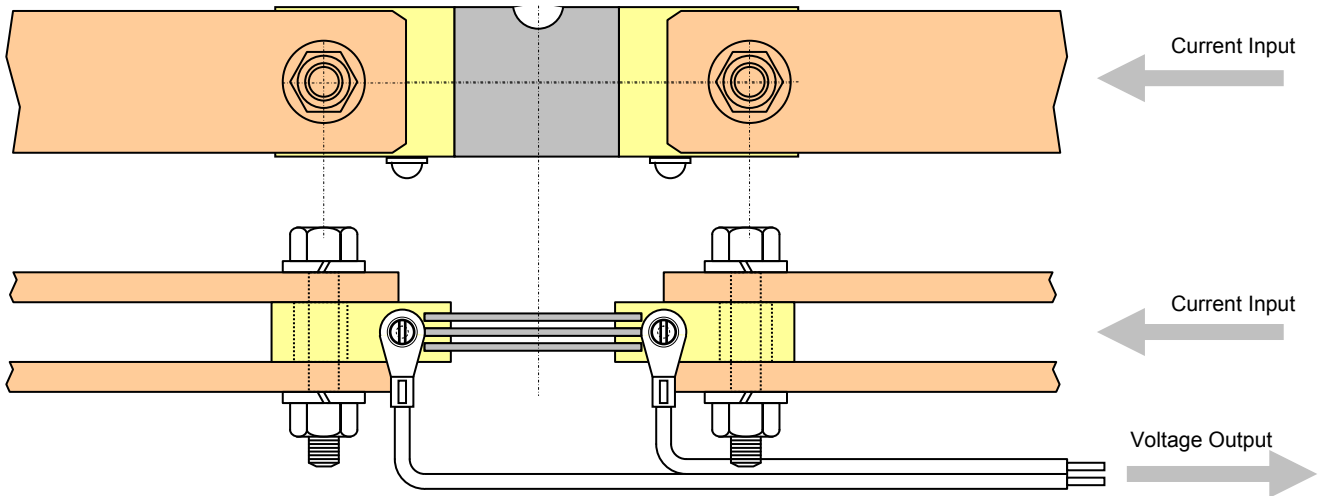

PRECISION CURRENT SHUNT RESISTORS

NSB300, NSB400, NSB500
 NSB600, NSB700, NSB800
 NSB1000, NSB1200

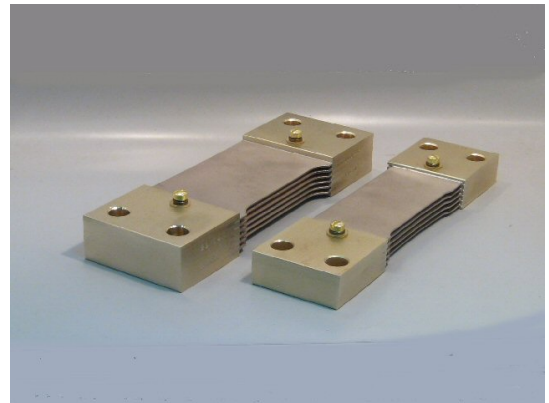

Features and Applications

- Large current shunt resistors for ampere-meters, designed for power electric equipment.
- Excellent long-term stability, low emf and low TCR.
- Easy current measurement is performed by attaching to current bus directory and connecting to ampere-meter through flexible wires.
- All of shunts are calibrated on equipment with current certifications traceable to US-N.I.S.T
- For high precision power supply, power converters, and current measurement instruments.

Dimension (mm)

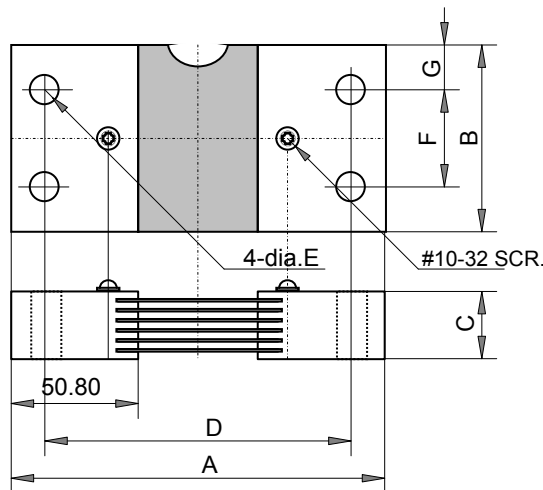

mm	NSB300-50	NSB400-50	NSB500-50	NSB600-50	NSB750-50	NSB800-50	NSB1000-50	NSB1200-50
A	149.23	149.23	149.23	149.23	149.23	149.23	149.23	149.23
B	44.45	50.80	50.80	50.80	57.15	60.33	63.50	76.20
C	12.70	19.05	19.05	19.05	19.05	19.05	25.40	25.40
D	120.65	120.65	120.65	120.65	120.65	120.65	120.65	120.65
E	11.13	11.13	11.13	11.13	11.13	11.13	11.13	11.13
F	25.40	31.75	31.75	31.75	38.10	38.10	38.10	38.10
G	9.53	9.53	9.53	9.53	9.53	9.53	12.70	19.05

mm	NSB300-100	NSB400-100	NSB500-100	NSB600-100	NSB750-100	NSB800-100	NSB1000-100	NSB1200-100
A	196.85	196.85	196.85	196.85	196.85	196.85	196.85	196.85
B	44.45	50.80	50.80	50.80	57.15	60.33	63.50	76.20
C	12.70	19.05	19.05	19.05	19.05	19.05	25.40	25.40
D	168.28	168.28	168.28	168.28	168.28	168.28	168.28	168.28
E	11.13	11.13	11.13	11.13	11.13	11.13	11.13	11.13
F	25.40	31.75	31.75	31.75	38.10	38.10	38.10	38.10
G	9.53	9.53	9.53	9.53	9.53	11.13	11.13	19.05

PRECISION CURRENT SHUNT RESISTORS

NSB300, NSB400, NSB500, NSB600, NSB700, NSB800 NSB1000, NSB1200

Ordering Information

Style NSB	Rated Current in A 300	Voltage in mV -50	Tolerance C	Code Z00
NSB	300 400 500 600 750 800 1000 1200	-50 -60 -100	C(+/-0.25%) (1)	Z00

- (1) Accuracy will be assured B(+/-0.1%) in option.
 (2) Recommended operation current shall be 2/3 of their rated current.

Specification and Performance

	NSB300	NSB400	NSB500	NSB600	NSB750	NSB800	NSB1000	NSB1200
Rated Current (A)	300	400	500	600	750	800	1000	1200
Operating Current (A)	200	267	333	400	500	533	667	800
Rated Output (mV)	50, 60 or 100							
Eq. Resistance(milliohms)	Resistance is based on the amperage and millivolt rating, nominal resistance is calculated using Ohms law.							
Voltage Tolerance (%)	+/-0.25%(C)							
Operating Temp. (deg C)	+30 to +70 deg C measured at center of manganin strips							
Storage Temp. (deg C)	-55 to +80 deg C							
Weight (Kg)								

The way to reduce the operating temperature, such as forced air, increasing physical size, adding heat sink to the blocks, designing for water cooling, and etc.

	50mV
NSB300-50	0.16666
NSB400-50	0.12500
NSB500-50	0.10000
NSB600-50	0.08333
NSB750-50	0.06666
NSB800-50	0.06250
NSB1000-50	0.05000
NSB1200-50	0.04166
	100mV
NSB300-100	0.33333
NSB400-100	0.25000
NSB500-100	0.20000
NSB600-100	0.16666
NSB750-100	0.13333
NSB800-100	0.12500
NSB1000-100	0.10000
NSB1200-100	0.08333

Thickness (mm)	Width (mm)	Current (A) at 30 deg C Temp. Rise	Current (A) at 65 deg C temp. Rise
3	25	230	362
4	25	290	456
4	50	510	802
5	25	340	535
5	50	610	960
6	25	380	598
6	30	430	675
6	40	550	865
6	50	680	1070
6	75	940	1479
6	100	1200	1888
6	125	1440	2265
6	150	1680	2643
8	50	800	1258
8	75	1100	1730
8	100	1400	2202
8	125	1650	2595
8	150	1930	3036
10	50	880	1384
10	75	1220	1919
10	100	1540	2422

Resistance (milliohm) calculated from the V-I characteristic.

Current capacity of copper bus bar, JSIA

20111201

PRECISION CURRENT SHUNT

NSE1500, NSE2000

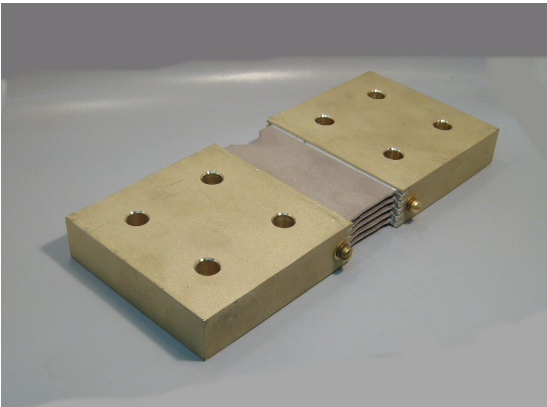

Features and Applications

- Large current shunt for ampere-meters, designed for power electric equipment.
- Excellent long-term stability, low emf and low TCR.
- Easy current measurement is performed by attaching to current bus directory and connecting to ampere-meter through flexible wires.
- All of shunts are calibrated on equipment with current certifications traceable to US-N.I.S.T
- For high precision power supply, EV charger, power converters, and current measurement instruments.

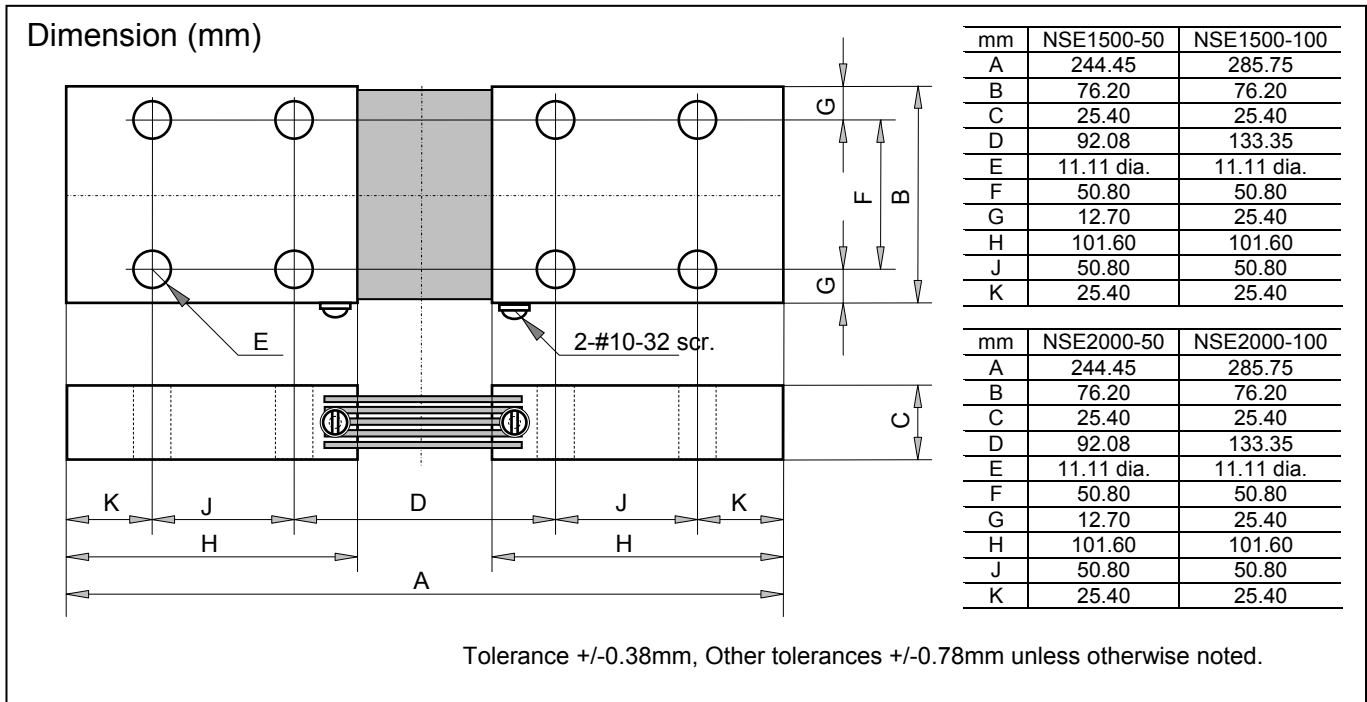

Ordering Information

Style NSE	Rated Current in A 1500	Voltage in mV -50mV	Tolerance C	Code Z00
NSE	1500 2000	-50mV (-60) option -100mV	C(+/-0.25%) (1)	Z00

- (1) Accuracy will be assure B(+/-0.1%) in option.
- (2) Recommended operation current shall be decreased 2/3 of their rated current.

PRECISION CURRENT SHUNT NSE1500, NSE2000

Specification and Performance

	NSE1500-50mV	NSE1500-100mV	NSE2000-50mV	NSE2000-100mV
Rated Current (A)	1500A	1500A	2000A	2000A
Operating Current (A)	1000A	1000A	1330A	1330A
Rated Output (mV)	50mV (60mV option)	100mV	50mV (60mV option)	100mV
Eq. Resistance(milliohms)	---	---	---	---
Voltage Tolerance (%)	Resistance is based on the amperage and millivolt rating, nominal resistance is calculated using Ohms law.			
Operating Temp. (deg C)	+/-0.25%(C)			
Strage Temp. (deg C)	+30 to +70 deg C measured at center of Manganin strips			
Weight (Kg)	-55 to +80 deg C			

The way to reduce the operating temperature, such as forced air, increasing physical size, adding heat sink to the blocks, designing for water cooling, and etc.

	milliohms
NSE1500-50mV	0.03333
NSE1500-100mV	0.06667
	milliohms
NSE2000-50mV	0.02500
NSE2000-100mV	0.05000

Resistance (milliohm) calculated from the V-I characteristic.

Thickness (mm)	Width (mm)	Current (A) at 30 deg C Temp. Rise	Current (A) at 65 deg C temp. Rise
3	25	230	362
4	25	290	456
4	50	510	802
5	25	340	535
5	50	610	960
6	25	380	598
6	30	430	675
6	40	550	865
6	50	680	1070
6	75	940	1479
6	100	1200	1888
6	125	1440	2265
6	150	1680	2643
8	50	800	1258
8	75	1100	1730
8	100	1400	2202
8	125	1650	2595
8	150	1930	3036
10	50	880	1384
10	75	1220	1919
10	100	1540	2422

Applications

Current capacity of copper bus bar, JSIA

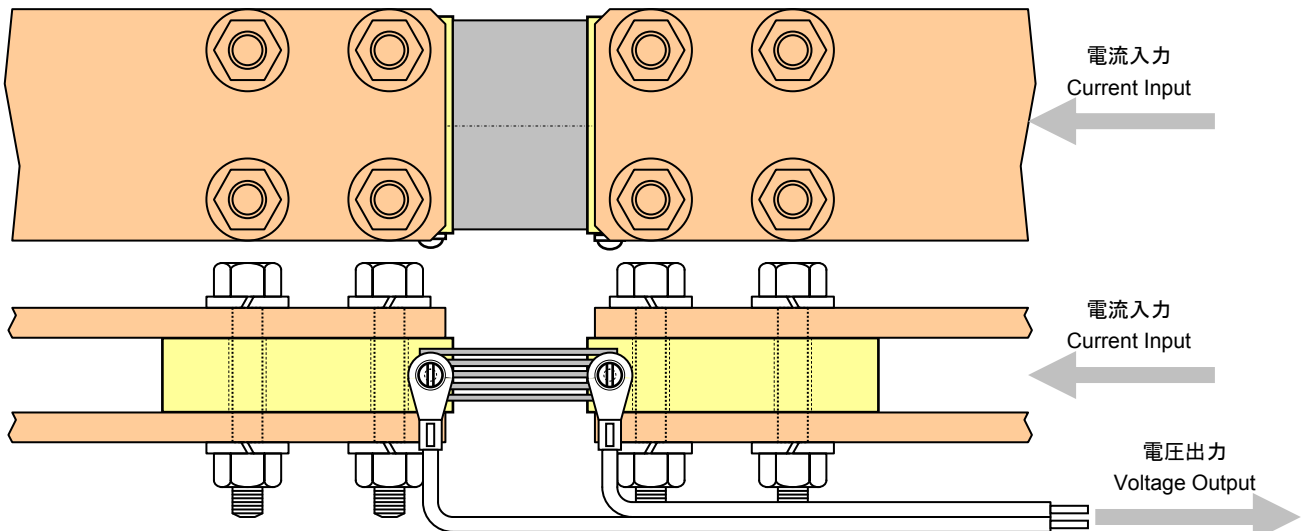

20111201

PRECISION CURRENT SHUNTS

NSF2500, NSF3000, NSF4000,
NSF5000, NSF6000, NSF7000,
NSF8000, NSF9000, NSF10000

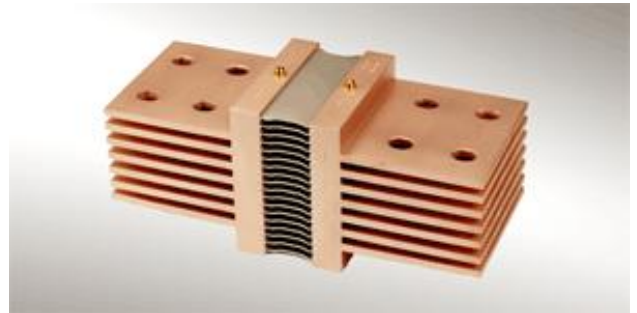

Features and Applications

- Large current shunt resistors for ampere-meters, designed for power electric equipment.
- Excellent long-term stability, low emf and low TCR.
- Easy current measurement is performed by attaching to current bus directory and connecting to ampere-meter through flexible wires.
- All of shunts are calibrated on equipment with current certifications traceable to US - N.I.S.T
- For high precision power supply, power converters, and current measurement instruments.
- Requirement for over 10,000A shunts, please call factory.

Dimensions (mm)

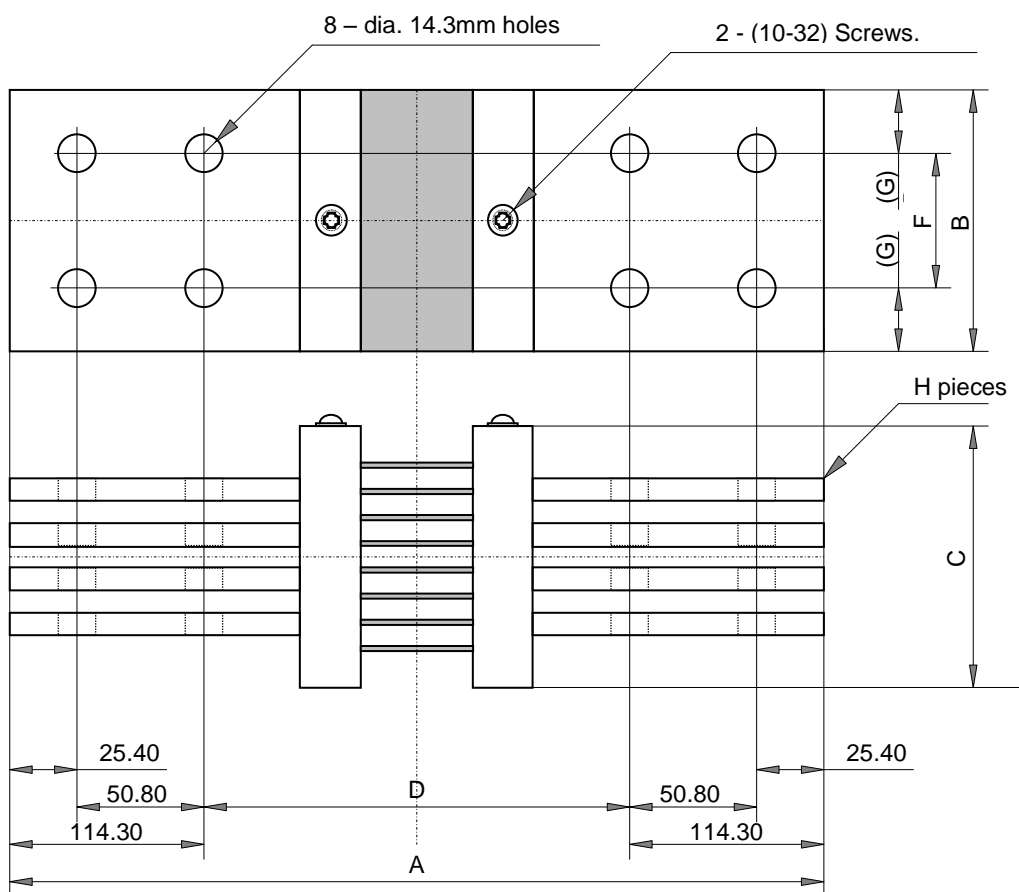

Thickness and gap of terminal blades are equal as 6.35mm.

PRECISION CURRENT SHUNTS

NSF2500, NSF3000, NSF4000, NSF5000, NSF6000, NSF7000, NSF8000, NSF9000, NSF10000

Dimensions (mm)

mm	NSF2500 -50	NSF3000 -50	NSF4000 -50	NSF5000 -50	NSF6000 -50	NSF7000 -50	NSF8000 -50	NSF9000 -50
A	320.68	320.68	320.68	320.68	320.68	320.68	320.68	320.68
B	101.6	101.6	101.6	101.6	101.6	127	127	127
C	38.1	50.8	76.2	76.2	101.6	101.6	101.6	101.6
D	168.28	168.28	168.28	168.28	168.28	168.28	168.28	168.28
F	50.8	50.8	50.8	50.8	50.8	63.5	63.5	63.5
G	25.4	25.4	25.4	25.4	25.4	31.75	31.75	31.75
H	2	3	4	4	5	5	6	6

mm	NSF2500 -100	NSF3000 -100	NSF4000 -100	NSF5000 -100	NSF6000 -100	NSF7000 -100	NSF8000 -100	NSF9000 -100
A	361.95	361.95	361.95	361.95	361.95	361.95	361.95	361.95
B	101.6	101.6	101.6	101.6	101.6	127	127	127
C	38.1	50.8	76.2	76.2	101.6	101.6	101.6	101.6
D	209.55	209.55	209.55	209.55	209.55	209.55	209.55	209.55
F	50.8	50.8	50.8	50.8	50.8	63.5	63.5	63.5
G	25.4	25.4	25.4	25.4	25.4	31.75	31.75	31.75
H	2	3	4	4	5	5	6	6

Dimensions tolerance: ± 0.381 mm for hole diameters. All other dimensions have a ± 0.762 mm tolerance.

Ordering Information

Style	Rated Current in A	Voltage in mV	Tolerance	Code
NSF	2500	-50	C	Z00
NSF	3000	-50	C(+/-0.25%)	Z00
	4000	-100		
	5000			
	6000			
	7000			
	8000			
	9000			
	10000			

- (1) 60mV, 75mV available
- (2) Accuracy will be assure B(+/-0.1%) in option.
- (3) Recommended operation current shall be 2/3 of their rated current.

Performances

	NSF2500	NSF3000	NSF4000	NSF5000	NSF6000	NSF7000	NSF8000	NSF9000	NSF10000
Rating Current (A)	2500	3000	4000	5000	6000	7000	8000	9000	10000
Operating Current (A)	1666	2000	2670	3330	4000	4670	5330	6000	6670
Output Volt. (mV)	50 or 100								
Cal. Resistance(mΩ)	Resistance is based on the amperage and millivolt rating, nominal resistance is calculated using Ohms law.								
Tolerance (%)	+/-0.25% (C)								
Operating Temp. (°C)	+30 to +70 deg C measured at center of manganin strips								
Storage Temp. (°C)	-55°C to +80 °C								
Weight (Kg)	Please call factory								

The way to reduce the operating temperature, such as forced air, increasing physical size, adding heat sink to the blocks, designing for water cooling, and etc.

20170401

RADIAL LEADS METAL FILM RESISTORS
 RP-84, RP-44, RP-24, RP-14

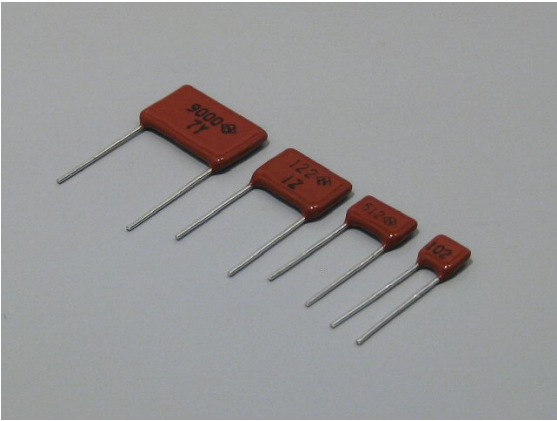

Features and Applications

- Radial leaded 1/8W-1/4W-1/2W-1W rating and up to 25ppm/K, 0.1% absolute in series.
- Precision Ni-Cr thin film resistors, applicable in general use.
- Color coded, lead forming and taping to be available in 1/4W and 1/2W.
- Featuring long-term stability, low noise, wide operating temperature range, and low failure rate.
- Communications, power control, Industrial measurements, automatic testing, medical, and high-ended audio systems.

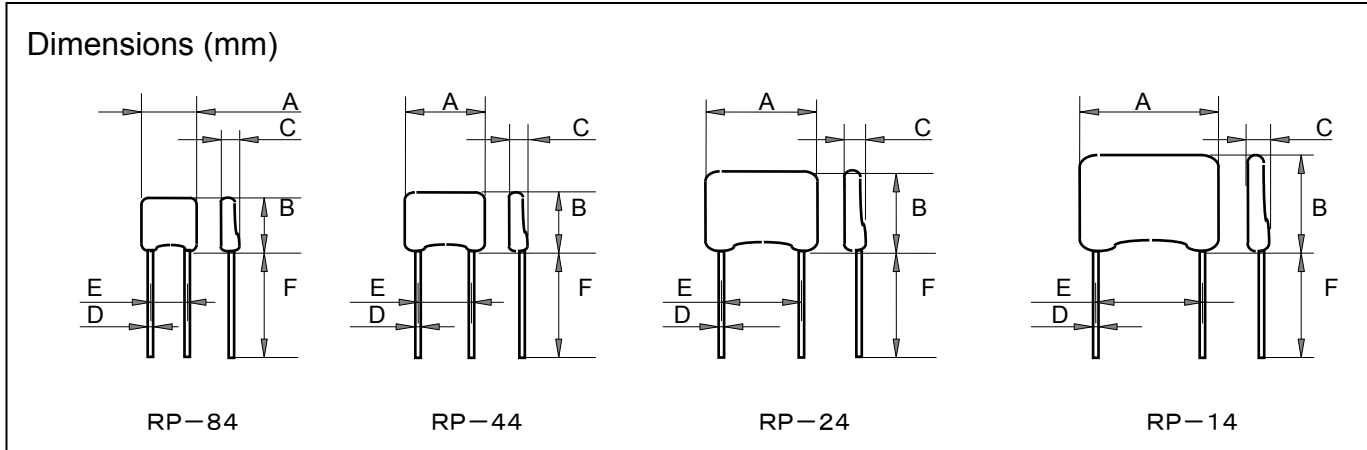

Type	A	B	C	D	E	F
RP-84	5.0max	5.0max	2.5max	0.5 dia.	2.5±0.5	10±2
RP-44	7.5max	5.5max	2.5max	0.5 dia.	5.0±0.5	10±2
RP-24	10.0max	7.5max	2.5max	0.5 dia.	7.5±0.5	10±2
RP-14	14.0max	8.5max	2.5max	0.5 dia.	10.0±0.5	10±2

Specifications and Performances

Type	RL84	RP-84	RT-84	RL44	RP-44	RT-44		
Lead Pitch	2.5mm			5.0mm				
Rating	1/8W			1/4W				
Resistance	0.1-9.1	47-33K	10-47K	47K-10M	0.1-9.1	47-180K	10-250K	270K-10M
Nominal Value	E12	E24, E96	E24	E24	E12, E24, E96	E24	E24	
TCR(+/-ppm/K)	250 (H)	25 (E)	50 (C)	100 (A)	250 (H)	25 (E)	50 (C)	100 (A)
Tolerance(+/-%)	5.0 (J)	0.1(B)	1.0(F)	2.0(G)	5.0(J)	0.1(B)	1.0(F)	2.0(G)
Lead-free	Z00			Z00	Z00	Z00	Z00	
Color Coded	Not available, Z00 only			NA	NA	A00	A00	
Lead Formed	Not available, Z00 only			010	NA	Z10	Z10	
Taping	Not available, Z00 only			Z02	Z02	Z02	Z02	
Working Voltages	√(PR)			√(PR)				
Rated Amb. Temp.	70 deg C			70 deg C				
Operating Temp.	-55 to +155 deg C			-55 to +155 deg C				

RADIAL LEADS METAL FILM RESISTORS

RP-84, RP-44, RP-24, RP-14

Specifications and Performances

P/N	RL24	RP-24		RT-24	RL14	RP-14		RT-14
Lead Pitch	7.5mm				10.0mm			
Rating	1/2W	1/4W	1/2W		1W	1/2W	1W	
Resistance	0.1-9.1	47-750K	10-1M	1M-10M	0.1-9.1	47-750K	10-1M	1M-10M
Nominal Value	E12	E24, E96	E24	E24	E12	E24, E96	E24	E24
TCR (ppm/deg C)	250(H)	25(E)	50(C)	100(A)	250(H)	25(E)	50(C)	100(A)
Tolerance (%)	5.0 (J)	0.1 (B)	1.0 (F)	2.0 (G)	5.0 (J)	0.1 (B)	1.0 (F)	2.0 (G)
Lead-free	Z00	Z00	Z00	Z00	Z00			
Color Coded	NA	NA	A00	A00	Not available, Z00 only			
Lead Formed	010	NA	Z10	Z10	Not available, Z00 only			
Taping	Z02	Z02	Z02	Z02	Not available, Z00 only			
Working Voltages	$\sqrt{(PR)}$				$\sqrt{(PR)}$			
Rated Amb. Temp.	70 deg C				70 deg C			
Operating Temp.	-55 to +155 deg C				-55 to +155 deg C			

Performance

	EB (25ppm, 0.1%)	CF (50ppm, 1.0%)	Test Condition
Short Time Overload	$\pm 0.10\%$	$\pm 0.25\%$	2.5 times rated power, 5 seconds.
Load Life	$\pm 0.10\%$	$\pm 0.5\%$	70 deg C, 90min., ON, 30min., OFF, 1000hours
Humidity	$\pm 0.25\%$	$\pm 0.5\%$	40degC,90-95%RH,90min.,ON,30min.,OFF, 1000hours.
Temperature Cycle	$\pm 0.10\%$	$\pm 0.25\%$	-55C, 30min., +155C, 30 min., 20 cycles.
Soldering Heat	$\pm 0.10\%$	$\pm 0.10\%$	4mm portion, 350C, 3 seconds, dipping.
Withstanding Volt.	$\pm 0.10\%$	$\pm 0.25\%$	
Terminal Strength	$\pm 0.10\%$	$\pm 0.25\%$	
Insulation Resistance	>10,000M Ω	>10,000M Ω	

Ordering Information

Type	TCR	Resistance	Tolerance	Code	Note
RP-24	C	10kohm	F	A10	Color-Forming-Bulk
RP-84	E	E96+	B	Z00	No color, no forming, bulk
RP-44	C	E24+	F	A00	Color*, no forming, bulk
RP-24				Z10	No color, forming**, bulk
RP-14				A10	Color*, forming**, bulk
				Z02	No color, no forming, tape***
				A02	Color*, no forming, tape***
				Z12	No color, forming**, tape***
				A12	Color*, forming**, tape***

* Color code printing is available only RP-44 and RP-24.

** Lead forming is available only RP-44 and RP-24.

*** Taping is available only RP-44 and RP-24.

Marking Stamp on Resistors

Type	RP-84EB	RP-84CF	RP-44EB	RP-44CF	RP-24EB	RP-24CF	RP-14EB	RP-14EB
Resistance	E24,E96	E24	E24,E96	E24	E24,E96	E24	E24,E96	E24
TCR	± 25 ppm	± 50 ppm	± 25 ppm	± 50 ppm	± 25 ppm	± 50 ppm	± 25 ppm	± 50 ppm
Tolerance	$\pm 0.1\%$	$\pm 1\%$	$\pm 0.1\%$	$\pm 1\%$	$\pm 0.1\%$	$\pm 1\%$	$\pm 0.1\%$	$\pm 1\%$
Marking	9092	103	9292N	103N	9092N 96	103N 96	9092N 96	103N 96
Tape Reel	NA	NA	3000pcs	3000pcs	2000pcs	2000pcs	NA	NA
Tape Box	NA	NA	2000pcs	2000pcs	2000pcs	2000pcs	NA	NA

RADIAL LEADS METAL FILM RESISTORS

RP-84, RP-44, RP-24, RP-14

Taping Dimensions

	Sym	RP-44	RP-24
Pitch, resistors	P	12.7±1.0	12.7±1.0
Pitch, send holes	Po	12.7±0.3	12.7±0.3
Gap tolerance, holes	P1,P2	3.85±0.5	2.6±0.5
		6.35±1.3	6.35±1.3
Pitch, lead wires	F1,F2	5.0±0.3	7.5±0.3
Fall resistor	Δh	0±2.0	0±2.0
Tape width	W	18.0±0.5	18.0±0.5
Tolerance, tape width	W1	9.0±0.75	9.0±0.75
Bottom of resistor	H	19.0±1.0	19.0±1.0
Top of resistor	H1	25.0 以下	26.0 以下
Hole diameter	Do	4.0φ±0.2	4.0φ±0.2
Thickness of tape	t	0.5±0.2	0.5±0.2

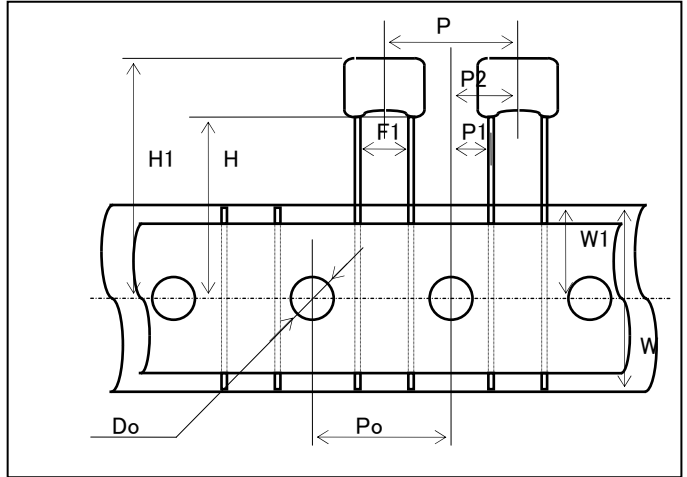

Taping Specification
Tape Folded, Type (- -2)

Color code (A- -)

Color	1 st	2 nd	Multiplier
BLACK	0	0	1
BROWN	1	1	10
RED	2	2	100
ORANGE	3	3	1000
YELLOW	4	4	10000
GREEN	5	5	100000
BLUE	6	6	1000000
PURPLE	7	7	10000000
GRAY	8	8	
WHITE	9	9	

Lead Forming (-1-)

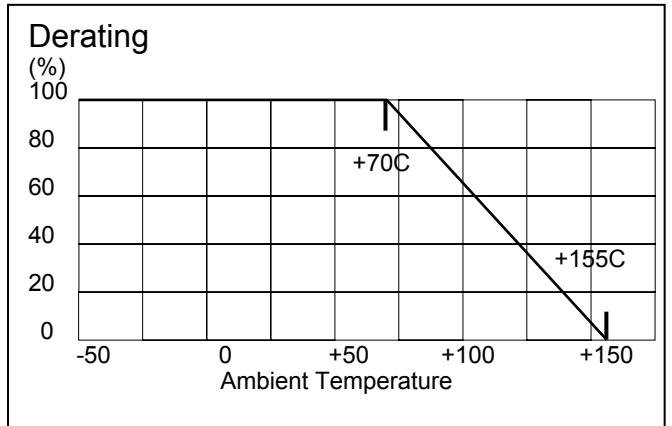

Note(1): As for marking specifications of RL type and RT type, call factory.
 Note(2): Zero Ohm resistor that are used for jumper are available.

1/4W, PRECISION THIN FILM RESISTORS

RP48, RP47, RP46, RP45

100mil-150mil-200mil-300mil pitch
Through-hole Precision Resistors, 2ppm-0.01%

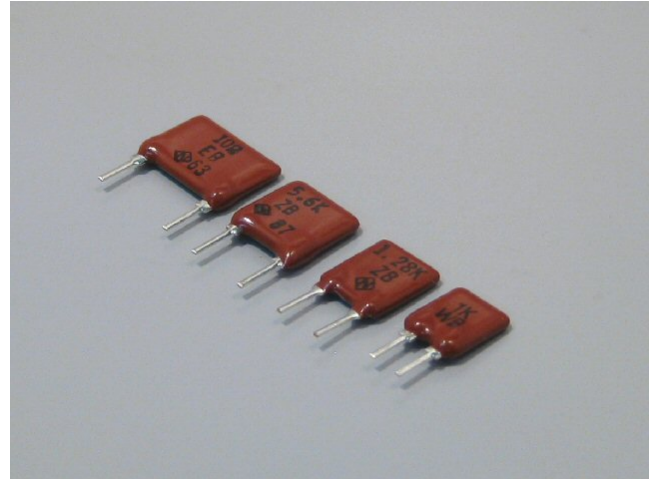

Features and Applications

High precision thin film resistors, typically 2ppm/C TC made by Ni-Cr alloy sputtered on alumina substrate, also 5ppm/K and 0.05% as standard.
Wide operating temperature range covered from -55 to 125C and absolutely linear (not bent) proportional dR vs. dT characteristics within the temperature range.
Sufficient rating power, long-term stability, low current noise, low voltage coefficient and low thermal EMF provided.
Easy to install on precision electronics by leaded style, shorter delivery than other type precision resistors, free from matching and tracking calculations, and economical.
Fit for discrete voltage dividers and common analog circuits of professional audio, sensor pre-amplifiers, industrial measurement, control, medical electronics, ATE, aerospace, and reliable power electronics.

Dimensions (mm)

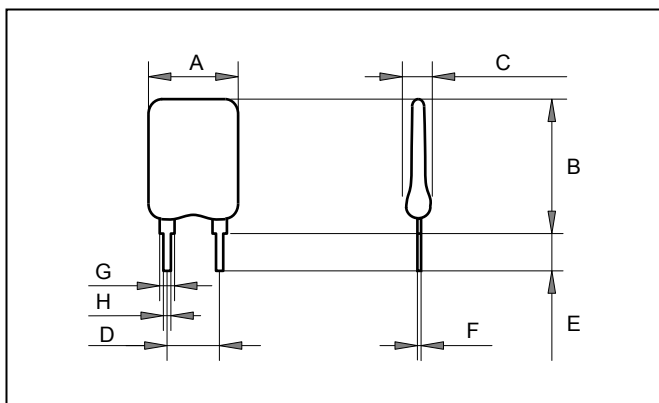

(mm)	RP48	RP47	RP46	RP45
A	5.6max	6.8max	8.0max	10.16max
B	8.2max	8.6max	9.0max	9.0max
C	2.54max	2.54max	2.54max	2.54max
D	2.54+/-0.25	3.81+/-0.25	5.08+/-0.25	7.62+/-0.25
E	3.3+/-0.5	3.3+/-0.5	3.3+/-0.5	3.3+/-0.5
F	0.25	0.25	0.25	0.25
G	1.2	1.2	1.2	1.2
H	0.5+/-0.05	0.5+/-0.05	0.5+/-0.05	0.5+/-0.05

Ordering Information

Type RP46	TCR W	Resistance 2.61Kohm	Tolerance A	Option Code Z00	Note
RP45	Y (2.0ppm/K)	See table	T(0.01%)	Z00 bulk	7.62mm
RP46	W (2.5ppm/K)		Q(0.02%)		5.08mm
RP47	Z (5.0ppm/K)		A(0.05%)		3.81mm
RP48	N (10ppm/K)		B(0.10%)		2.54mm
	E (25ppm/K)		D(0.25%)		

1/4W, PRECISION THIN FILM RESISTORS RP48, RP47, RP46, RP45

Specifications

P/N	RP48, RP47					Notes
Resistance Range (ohm)	100-20K	100-150K	100-150 K	50-150K	10-150K	
Absolute TCR (+/-ppm/K)	1(X)(*1)	2(Y), 2.5(W)	5(Z)	10(N)	25(E)	-55 to +125 deg C
Absolute Tolerance (+/-%)	0.01(T)(*1)	0.02(Q)	0.05(A)	0.1(B)	0.1(B)	-55 to +125 deg C
Standard Resistance	E96** and E24**, include 2.5 and 5.0 / any resistance value*					
Rating Power (Watts)	0.25W					-55 to+70 degC
Max Working Voltages (V)	$\sqrt{P \cdot R}$					

P/N	RP46, RP45					Notes
Resistance Range (ohm)	100-20K	100-150K	100-150 K	50-510K	10-820K	
Absolute TCR (+/-ppm/K)	1(X) (*1)	2(Y), 2.5(W)	5(Z)	10(N)	25(E)	-55 to +125 degC
Absolute Tolerance (+/-%)	0.01(T) (*1)	0.02(Q)	0.05(A)	0.1(B)	0.1(B)	-55 to +125 degC
Standard Resistance	E96** and E24**, include 2.5 and 5.0 / any resistance value*					
Rating Power (Watts)	0.25W					-55 to+70 degC
Max Working Voltages (V)	$\sqrt{P \cdot R}$					

Note* 4 or more significant resistance and odd resistance, please call factory about printing method.

Note* Precision, 1ppm/degC and 0.01% is optional, resistor will be supplied with data one by one.

Note: When another combination of Resistance-TCR-Tolerance is required, please call factory.

Performances

	Specification	Conditions and Note
Noise	< -43dB	
Voltage Coefficient	< 0.1ppm/V	THD at rating power < -120dB
Thermal EMF	0.05 uV/C	
Temperature Cycle	+/-0.05%	-55C30min, +120C30min, 20cycles.
Short Time Over Load	+/-0.05%	Rating Power×2.5, 5seconds
Solder ability	Covered 95%	235C, 2seconds
Solvent	No damage	IPA test
Terminal Strength	+/-0.05%	
Withstanding Voltage	+/-0.03%	
Soldering Heat	+/-0.03%	350C, 3seconds.
Vibration	Not specified	
Load Life	+/-0.05%	1000 hours
Humidity	+/-0.05%	1000 hours
Shelf Life Stability	+/-0.03%	One year at 25C
Operating Temp.	-55 to +125C	
Storage Temp.	-55 to +125C	

TCR and Tolerance Identifications

TCR and Symbols		Tolerance and Symbols	
X	+/-1ppm/C	T	+/-0.01%
Y	+/-2ppm/C	Q	+/-0.02%
W	+/-2.5ppm/C	A	+/-0.05%
Z	+/-5ppm/C	B	+/-0.10%
N	+/-10ppm/C	D	+/-0.50%
E	+/-25ppm/C	F	+/-1.0%
C	+/-50ppm/C		

Resistance, E24+

1.0	1.5	2.2	3.0	4.3	5.6	8.2
1.1	1.6	2.4	3.3	4.7	6.2	9.1
1.2	1.8	(2.5)	3.6	(5.0)	6.8	
1.3	2.0	2.7	3.9	5.1	7.5	

E96 Resistance, E96

1.00	1.21	1.47	1.78	2.15	2.61	3.16	3.83	4.64	5.62	6.81	8.25
1.02	1.24	1.50	1.82	2.21	2.67	3.24	3.92	4.75	5.76	6.98	8.45
1.05	1.27	1.54	1.87	2.26	2.74	3.32	4.02	4.87	5.90	7.15	8.66
1.07	1.30	1.58	1.91	2.32	2.80	3.40	4.12	4.99	6.04	7.32	8.87
1.10	1.33	1.62	1.96	2.37	2.87	3.48	4.22	5.11	6.19	7.50	9.09
1.13	1.37	1.65	2.00	2.43	2.94	3.57	4.32	5.23	6.34	7.68	9.31
1.15	1.40	1.69	2.05	2.49	3.01	3.65	4.42	5.36	6.49	7.87	9.53
1.18	1.43	1.74	2.10	2.55	3.09	3.74	4.53	5.49	6.65	8.06	9.76

PRECISION
RADIAL LEADED THIN FILM RESISTORS

RP-102, RP-82, RP-41, RP-42,
RP-22, RP-23, RP-12, RP-203,
RP-303

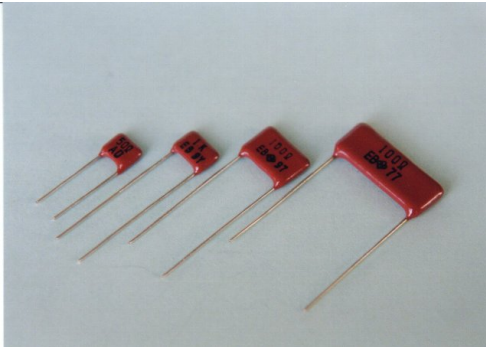

Features and Applications

Radial leaded, through-hole 1/10W, 1/8W, 1/4W, 1/2W, 1W, 2W, 3W rating and up to 5ppm/C, 0.1% absolute in series. Any resistance value available.
Long life, precision Ni-Cr thin film resistors, applicable in general use for industrial circuits with sufficient power derating.
Date code printing on resistor surface helpful in realizing traceability
Featuring long-term stability, low noise, wide operating temperature range and low failure rate.
Suitable for industrial electronics applications of 5-15-24-48V circuits such as data transmission, train control, electric power control, industrial machines, industrial measurements, automatic testing, medical and low noise high-ended audio systems.

Dimensions (mm)

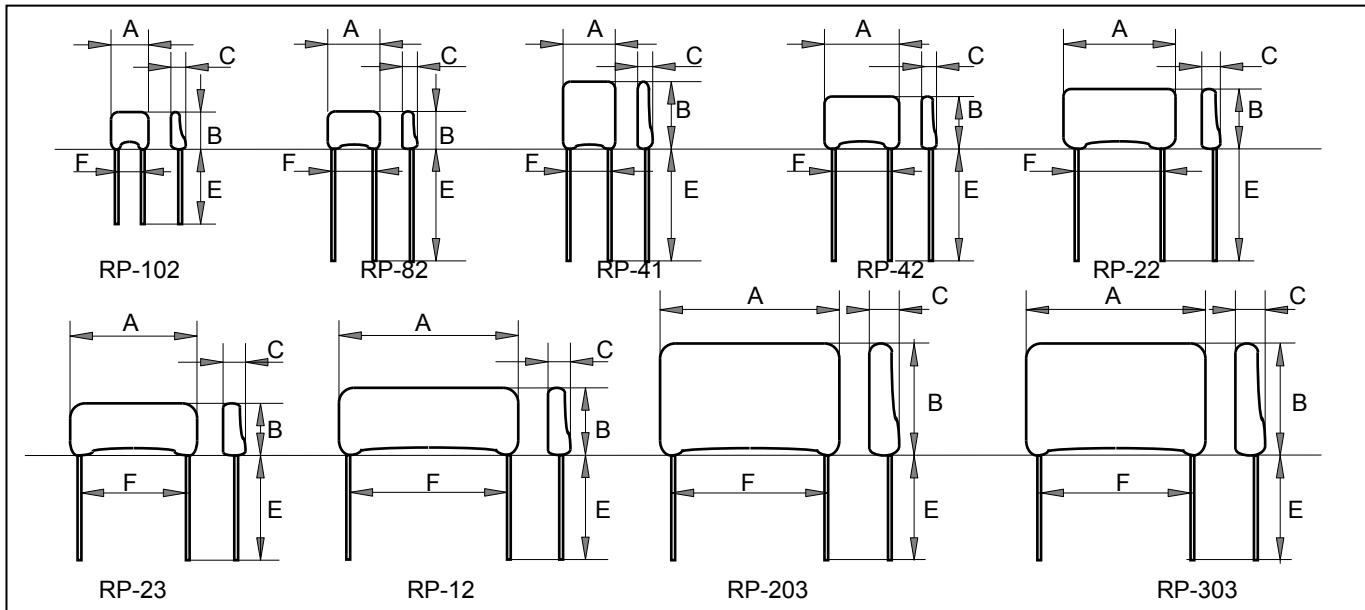

Type	Rating	A	B	C	D (Leads)	E	F
(RP84)	1/8W	5.0max	5.0max	2.5max	0.5 dia	10+/-2	2.5+/-0.5
RP-102	1/8W	5.0+/-1	4.05+/-0.5	1.8+/-0.5	0.5 dia	10+/-2	3.5+/-0.5
RP-82	1/4W	6.3+/-1	4.05+/-0.5	2.2+/-0.5	0.5 dia	25+/-5	5.0+/-0.5
RP-41	1/2W	6.3+/-1	9.0+/-1.0	2.2+/-0.5	0.5 dia	25+/-5	5.0+/-0.5
RP-42	1/2W	9.0+/-1	6.3+/-1.0	2.2+/-0.5	0.5 dia	25+/-5	7.5+/-0.5
(RP-14)	1W	14.0max	8.5max	2.5max	0.5 dia	10+/-2	10.0+/-0.5
RP-22	1W	15.0+/-1	8.0+/-1.0	2.8+/-0.8	0.5 dia	25+/-5	12.5+/-0.5
RP-23	1W	17.0+/-1.5	6.3+/-1.0	2.8+/-0.8	0.5 dia	25+/-5	15.0+/-0.5
RP-12	2W	22.5+/-1.5	9.0+/-1.0	2.8+/-0.8	0.8 dia	25+/-5	20.0+/-0.5
RP-203	3W	22.5+/-1.5	15.0+/-1.0	3.55+/-1.0	0.8 dia	25+/-5	20.0+/-0.5
RP-303	4W	22.5+/-1.5	15.0+/-1.0	4.25+/-1.0	0.8 dia	25+/-5	20.0+/-0.5

Note 1: (RP-84) and (RP-14) in dimensional was shown only to select from leads pitch variety.

PRECISION RADIAL LEADED THIN FILM RESISTORS

RP-102, RP-82, RP-41, RP-42, RP-22, RP-23, RP-12, RP-203, RP-303

Specifications (Resistance Range in ohm)

Type	Power	Z---B	E---B	C---F	A---J	H---J
		5ppm/C, 0.1%	25ppm/C, 0.1%	50ppm/C, 1%	100ppm/C, 5%	250ppm/C, 5%
RP-102	1/8W	NA	51-10K	10-22K	5-51K	NA
RP-82	1/4W	100-100K	51-180K	10-250K	5-250K	1-250K
RP-41	1/2W	100-100K	10-402K	10-510K	5-510K	1-1M
RP-42	1/2W	100-100K	47-750K	10-1M	5-1M	1-1M
RP-22	1W	100-100K	51-1M	10-1M	5-1M	1-5.1M
RP-23	1W	100-100K	51-1M	10-1M	5-1M	1-5.1M
RP-12	2W	NA	51-1M	10-1M	5-3M	1-10M
RP-203	3W	NA	51-1M	10-1M	5-5M	1-15M
RP-303	4W	NA	51-1M	10-1M	5-5M	1-15M

Note 1: Power rating notations had been changed from previous specifications by results of long term test.

Note 2: Any combination of TCR and tolerance are available, as such as A---F(100ppm-1%), Z---D(5ppm-0.5%) or C---B.

Performances

	E-B(25ppm, 0.1%)	C-F(50ppm, 1.0%)	Conditions
Resistance Value	47-1Mohm	19-1Mohm	Any Value
TCR	25ppm/C	50ppm/C	
Tolerance	0.1%	1.0%	
Rated Ambient Temp.	-55-+70C	-55-+70C	
Operating Temp. Range	-55-+155C	-55-+155C	
Storage Temp. Range	-55-+155C	-55-+155C	
Max Applied Voltage	350V	500V	
Short Time Overload	+/- (0.10%+0.01ohm)	+/- (0.25%+0.01 ohm)	2.5 times rated power, 5 seconds.
Load Life	+/- (0.10%+0.01 ohm)	+/- (0.5%+0.01 ohm)	70C, 90min., on, 30min., off, 1000hours
Humidity	+/- (0.25%+0.01 ohm)	+/- (0.5%+0.01 ohm)	40C,90-95%RH,90min.,on,30min.,off, 1000h.
Temperature Cycle	+/- (0.10%+0.01 ohm)	+/- (0.25%+0.01 ohm)	-55C, 30min., +155C, 30 min., 20 cycles.
Soldering Heat	+/- (0.10%+0.01 ohm)	+/- (0.10%+0.01 ohm)	4mm portion, 350C, 3 seconds, dipping.
Withstanding Volt.	+/- (0.10%+0.01 ohm)	+/- (0.25%+0.01 ohm)	
Terminal Strength	+/- (0.10%+0.01 ohm)	+/- (0.25%+0.01 ohm)	
Insulation Resistance	>10,000Megohm	>10,000Megohm	

Ordering Information

P/N	Type	TCR	Resistance	Tolerance	RoHS Code	Notes
RP82Z90R2BZ00	RP82	Z(5ppm/C)	90.2ohm	B(0.1%)	Z00	
RP41E5K49BZ00	RP41	E(25ppm/C)	5.49Kohm	B(0.1%)	Z00	
RP42C103FZ00	RP42	C(50ppm/C)	10Kohm	F(1.0%)	Z00	
RP23E251BZ00	RP23	E(25ppm/C)	250ohm	B(0.1%)	Z00	

TCR and Tolerance

TCR		Tolerance	
X	+/-1ppm/K	T	+/-0.01
Z	+/-5 ppm/K	B	+/-0.1 %
N	+/-10 ppm/K	C	+/-0.25 %
E	+/-25 ppm/K	D	+/-0.5 %
C	+/-50 ppm/K	F	+/-1 %
A	+/-100 ppm/K	G	+/-2 %
H	+/-250 ppm/K	J	+/-5 %

Note 3 : Up to TCR±1ppm/K, tolerance+/-0.01% are available. Please call factory.

20090101

1/4W, 1/2W, 1W, 2W Thin Film Precision Chip
 R1206, R1210, R2010, R2512, R3020

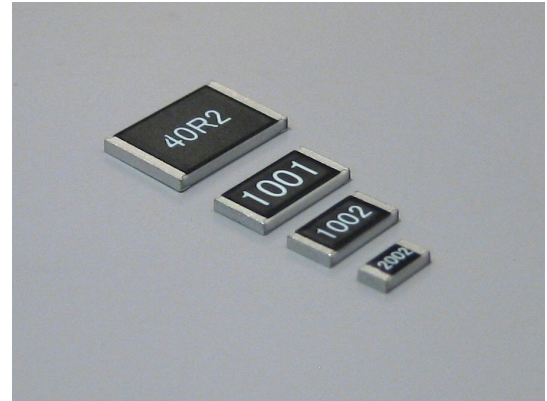

Features and Applications

Thin film precision chip resistor, 2.5ppm/deg C TC and 0.05% tolerance is standard.

Ni-Cr alloy thin film resistor, which is made by the advanced Nikkohm process deposited on alumina ceramic substrate and offer the features of long term stability and very low TC.

Applications: Industrial measurement, control electronics and automatic test equipment.

Dimensional Specifications (mm)

Materials

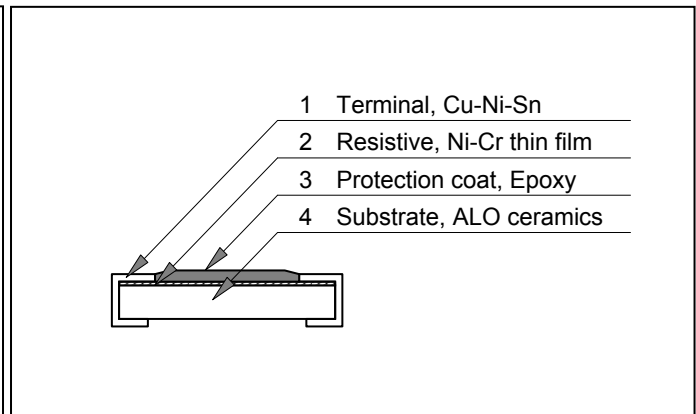
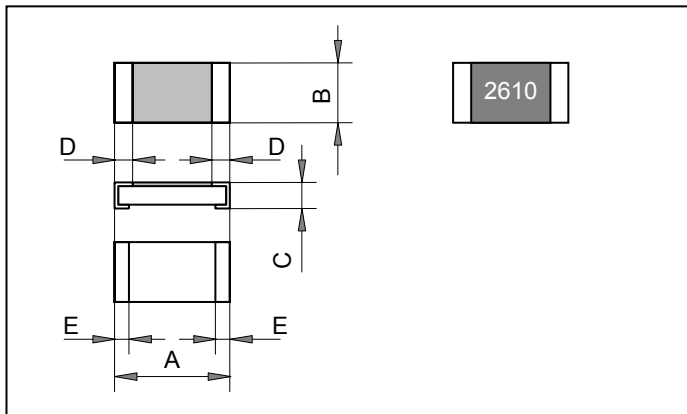

	R1206-0.25W	R1210-0.25W	R2010-0.5W	R2512-1W	R3020-2W
A	3.05+/-0.2	3.05+/-0.2	5.08+/-0.2	6.35+/-0.2	7.62+/-0.2
B	1.53+/-0.2	2.54+/-0.2	2.54+/-0.2	3.05+/-0.2	5.08+/-0.2
C	0.70+/-0.1	0.70+/-0.1	0.70+/-0.1	0.70+/-0.1	0.70+/-0.1
D	0.41+/-0.3	0.41+/-0.3	0.58+/-0.3	0.58+/-0.3	0.58+/-0.3
E	0.36+/-0.2	0.36+/-0.2	0.51+/-0.2	0.51+/-0.25	0.51+/-0.25

Ordering Information

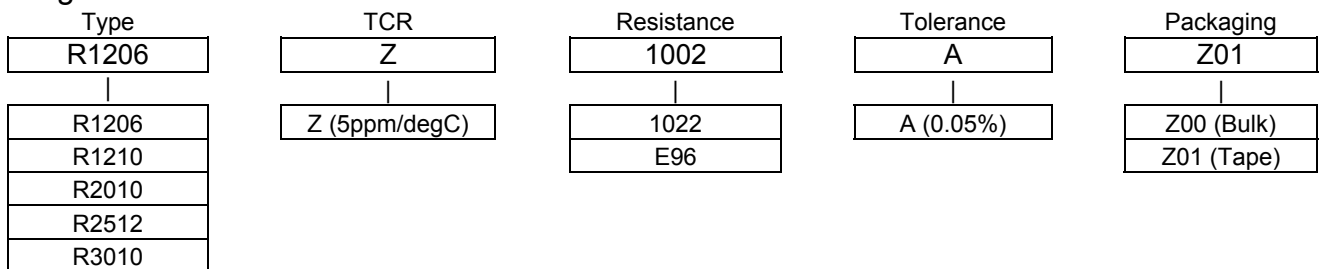

1/4W, 1/2W, 1W, 2W Precision Chip

R1206, R1210, R2010, R2512, R3020

Resistance Value, E24+ & E96+

1.00	1.02	1.05	1.07	1.10	1.13	1.15	1.18	1.20	1.21	1.24	1.27	1.30	1.33	1.37	1.40	1.43	1.47	1.50	1.54
1.58	1.60	1.62	1.65	1.69	1.74	1.78	1.80	1.82	1.87	1.91	1.96	2.00	2.05	2.10	2.15	2.20	2.21	2.26	2.32
2.37	2.40	2.43	2.49	2.50	2.55	2.61	2.67	2.70	2.74	2.80	2.87	2.94	3.00	3.01	3.09	3.16	3.24	3.30	3.32
3.40	3.48	3.57	3.60	3.65	3.74	3.83	3.90	3.92	4.02	4.12	4.22	4.30	4.32	4.42	4.53	4.64	4.70	4.75	4.87
4.99	5.00	5.10	5.11	5.23	5.36	5.49	5.60	5.62	5.76	5.90	6.04	6.19	6.20	6.34	6.49	6.65	6.80	6.81	6.98
7.15	7.32	7.50	7.68	7.87	8.06	8.20	8.25	8.45	8.66	8.87	9.09	9.10	9.31	9.53	9.76				

TCR and Tolerance Identifications

TCR	
TCR	Symbols
+/- 5ppm/C	Z

Tolerance	
Tolerance	Symbols
+/- 0.05%	A

Specifications

	R1206	R1210	R2010	R2512	R3020
Resistance	25-50Kohm	25-50Kohm	1-100kohm	1-100Kohm	1-100Kohm
TCR	+/-5ppm(Z)	+/-5ppm(Z)	+/-5ppm(Z)	+/-5ppm(Z)	+/-5ppm(Z)
Tolerance	+/-0.05%(A)	+/-0.05%(A)	+/-0.05%(A)	+/-0.05%(A)	+/-0.05%(A)
Resistance Value	E96, E24	E96, E24	E96, E24	E96, E24	E96, E24
Rating Powers	0.25W	0.25W	0.5W	1.0W	2W
Working Voltages	50VDC または $E = \sqrt{P \cdot R}$				
Operating Temp.	-25 deg C to +125 deg C				
Storage Temp.	-25 deg C to +125 deg C				

Performances

	R1206, R1210, R2010, R2512, R3020	条件 Conditions
Short Time Overload	+/- 0.05%	2.5 times rated power, 5seconds.
Insulating Voltage	+/- 0.01%	
Withstanding Voltage	+/- 0.01%	
Heat Shock	+/- 0.05%	
Vibration	+/- 0.01%	
Soldering Heat	+/- 0.05%	260 degree deg C, 10+/-1seconds.
Solder ability	90%	
Solvent	None	
Terminal Strength	+/- 0.05%	
Humidity	+/- 0.05%	40C, 90-95RH, DC0.1W, 1000hours
Load Life	+/- 0.05%	70 deg C, Rated Power, 90min ON, 30min OFF, 1000hours
Thermal EMF	---	
PCT	+/-0.05%	100H, Typical
Long Term Stability	+/-50ppm/year	Room Temperature, Typical

1/4W, 1/2W, 1W, 2W Precision Chip
R1206, R1210, R2010, R2512, R3020

Frequency Characteristics

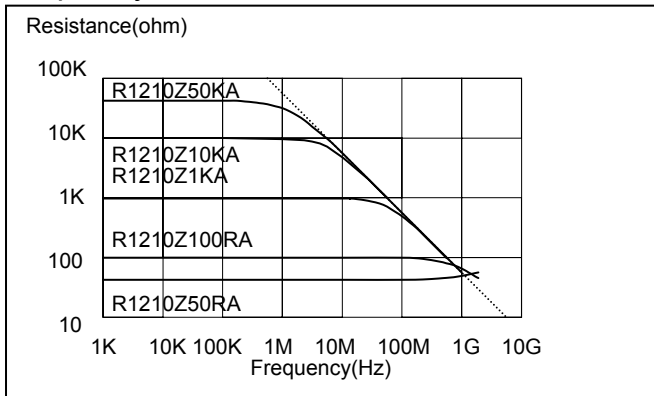

Temperature Characteristics

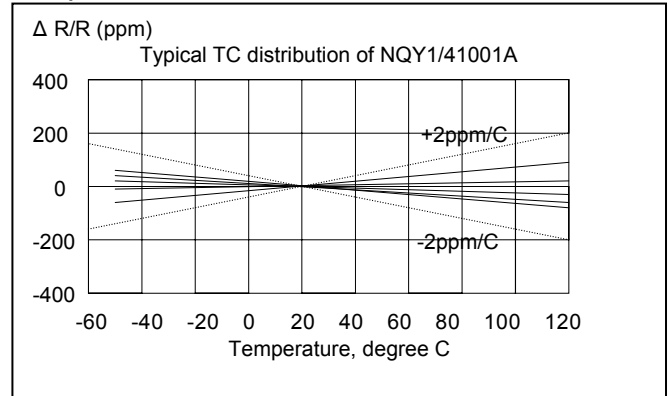

Packaging (please call factory)

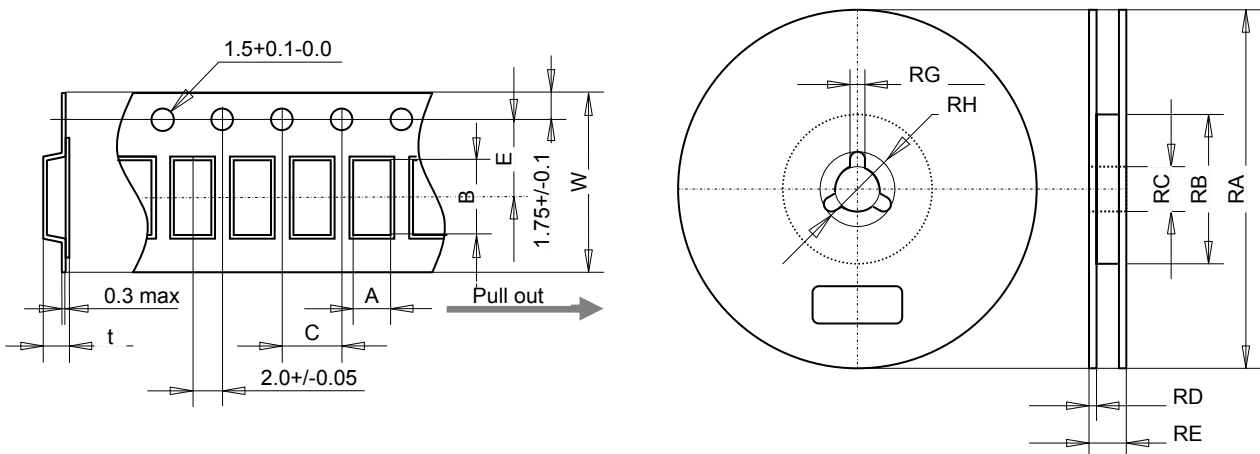

Tap Dimensions

	A	B	C	W	E	t	Note
R1206	2.00±0.15	3.60±0.15	4.0±0.1	8.0±0.2	3.50±0.05	1.0 max.	
R1210	2.85±0.15	3.50±0.15		8.0±0.2	3.50±0.05	1.0±0.20	
R2010	3.10±0.15	5.50±0.15		12.30±0.2	5.50±0.05	1.1±0.15	
R2512	3.60±0.15	6.90±0.15		12.30±0.2	5.50±0.05	1.1±0.15	
R3020							

Reel Dimensions

	RA	RB	RC	RD	RE	RG	RH
R1206	φ 180±0/-1.5	φ 60±1/-0	φ 13±0/-0.2	9.0±1.0/-0.0	11.4±/-1.0	2.0±/-0.5	21±/-0.8
R1210							
R2010							
R2512					13.0±/-1.0		
R3020							

Quantity per Reel

	Quantity
R1206	500pcs, 1000pcs, 2000cs
R1210	500pcs, 1000pcs, 2000pcs
R2010	500pcs, 1000pcs, 2000pcs
R2512	500pcs, 1000pcs
R3020	500pcs, 1000pcs

20120401

1/8W, 1/4W Precision Chip Resistors

NQA18, NQA14

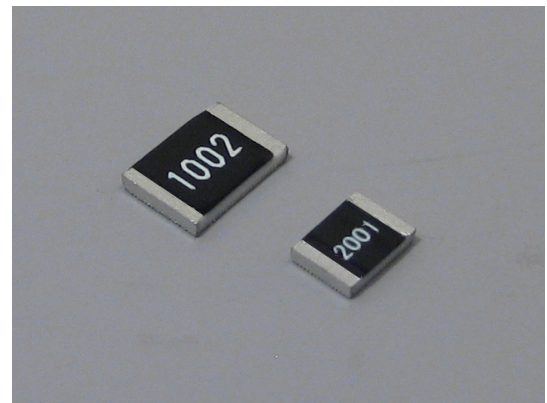

Features and Applications

Thin film precision chip resistor, 5ppm/deg C TCR and 0.05% tolerance is in standard.
2.5ppm/C, 0.05% is available.

Ni-Cr alloy thin film resistor, which is made by the advanced Nikkohm process deposited on alumina ceramic substrate and offer the features of long term stability and very low TCR.

Application includes Industrial measurement, control electronics and automatic test equipment.

Dimensional Specifications (mm)

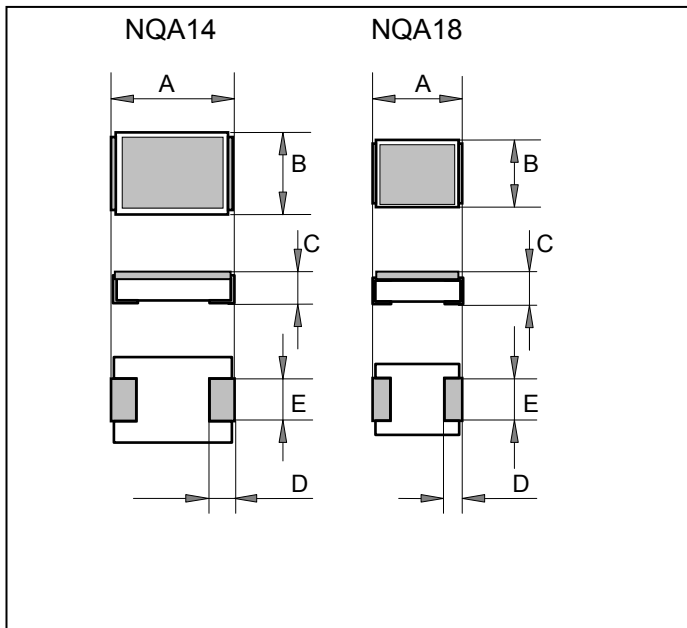

	NQA18	NQA14
A	3.2+/-0.2	4.5+/-0.2
B	2.5+/-0.2	3.2+/-0.2
C	1.0max.	1.0max.
D	0.8+/-0.3	1.0+/-0.3
E	1.4+/-0.3	1.4+/-0.3

Marking

- (1) Marking shall be done with a method of IEC 4digits notation on each resistors.
- (2) Type, TCR, resistance, tolerance, date-code manufacturer marking are print on surface of packaging.



Ordering Information

Type NQA14	TCR Z	Resistance 1131	Tolerance A	Code Z01	Note
NQA18	Z (5ppm/K)	E24+ & E96	A (0.05%)	Z00	Bulk (1)
NQA14		10-33kohm (2)		Z01	Tape reel

Note: (1) Bulk packing (100pcs) and tape reel packing are available.
(2) TCR and tolerance will be 5ppm-0.1% in resistance 10ohm-99ohm

1/8W, 1/4W Precision Chip Resistors.

NQA18, NQA14

Specifications

Type	NQA18(1)(2)		NQA14(1)(2)	
Resistance	10-33K	100-33K	10-62K	100-62K
TCR	5ppm(Z)	5ppm(Z)	5ppm(Z)	5ppm(Z)
Tolerance	0.1%(B)	0.05%(A)	0.1%(B)	0.05%(A)
Resistance Value	E24+, E96	E24+, E96	E24+, E96	E24+, E96
Rating Powers	0.125W		0.25W	
Working Voltages	50VDC or $E = \sqrt{P \cdot R}$		100VDC or $E = \sqrt{P \cdot R}$	
Operating Temp.	-55 to +125 deg C		-55 to +125 deg C	
Storage Temp.	-55 to +125 deg C		-55 to +125 deg C	

Performances

Term	NQA18	NQA14	Conditions
Short Time Overload	+/- 0.05%	+/- 0.05%	2.5 times rated power, 5seconds.
Insulating Voltage	+/- 0.01%	+/- 0.01%	
Withstanding Voltage	+/- 0.01%	+/- 0.01%	
Heat Shock	+/- 0.05%	+/- 0.05%	
Vibration	+/- 0.01%	+/- 0.01%	
Soldering Heat	+/- 0.05%	+/- 0.05%	260C, 10+/-1seconds.
Solder ability	---	---	
Solvent	---	---	
Terminal Strength	+/- 0.05%	+/- 0.05%	
Humidity	+/- 0.05%	+/- 0.05%	40C, 90-95RH, DC0.1W, 1000hours
Load Life	+/- 0.05%	+/- 0.05%	70C, Rated Power, 90min ON, 30min OFF, 1000hours
Thermal EMF	---	---	
PCT	+/-0.05%	+/-0.05%	100H, Typical
Long Term Stability	+/-50ppm/year	+/-50ppm/year	Room Temperature, Typical

Frequency Characteristics

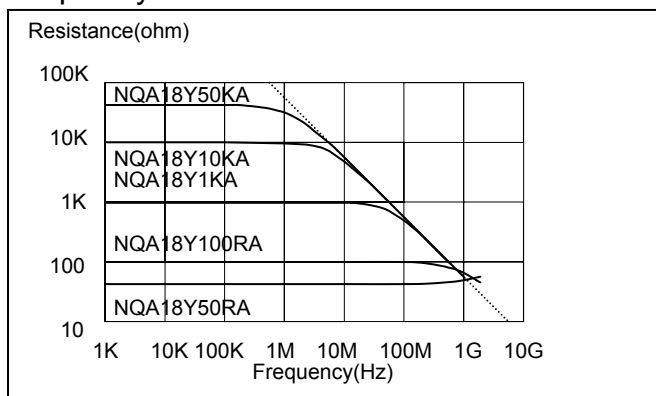

Temperature Characteristics

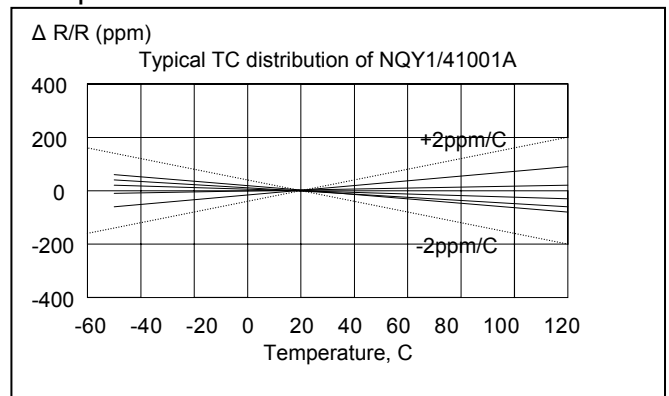

1/8W, 1/4W Precision Chip Resistors

NQA18, NQA14

TCR and Tolerance Notation (for reference only)

TCR	
TCR	Symbols
+/- 1.0 ppm/C	X
+/- 2.0 ppm/C	Y
+/-2.5 ppm/C	W
+/- 5.0 ppm/C	Z
+/-10 ppm/C	N

Tolerance	
Tolerance	Symbols
+/- 0.01 %	T
+/- 0.02 %	Q
+/- 0.025 %	---
+/- 0.05 %	A
+/-0.10 %	B

Resistance Value, Standard

E24+ (includes 2.5 and 5.0)												
1.0	1.1	1.2	1.3	1.5	1.6	1.8	2.0	2.2	2.4	(2.5)	2.7	3.0
3.3	3.6	3.9	4.3	4.7	(5.0)	5.1	5.6	6.2	6.8	7.5	8.2	9.1

E96												
1.00	1.02	1.05	1.07	1.10	1.13	1.15	1.18	1.21	1.24	1.27	1.30	1.33
1.37	1.40	1.43	1.47	1.50	1.54	1.58	1.62	1.65	1.69	1.74	1.78	1.82
1.87	1.91	1.96	2.00	2.05	2.10	2.15	2.21	2.26	2.32	2.37	2.43	2.49
2.55	2.61	2.67	2.74	2.80	2.87	2.94	3.01	3.09	3.16	3.24	3.32	3.40
3.48	3.57	3.65	3.74	3.83	3.92	4.02	4.12	4.22	4.32	4.42	4.53	4.64
4.75	4.87	4.99	5.11	5.23	5.36	5.49	5.62	5.76	5.90	6.04	6.19	6.34
6.49	6.65	6.81	6.98	7.15	7.32	7.50	7.68	7.87	8.06	8.25	8.45	8.66
8.87	9.09	9.31	9.53	9.76								

Tape Dimensions (mm)

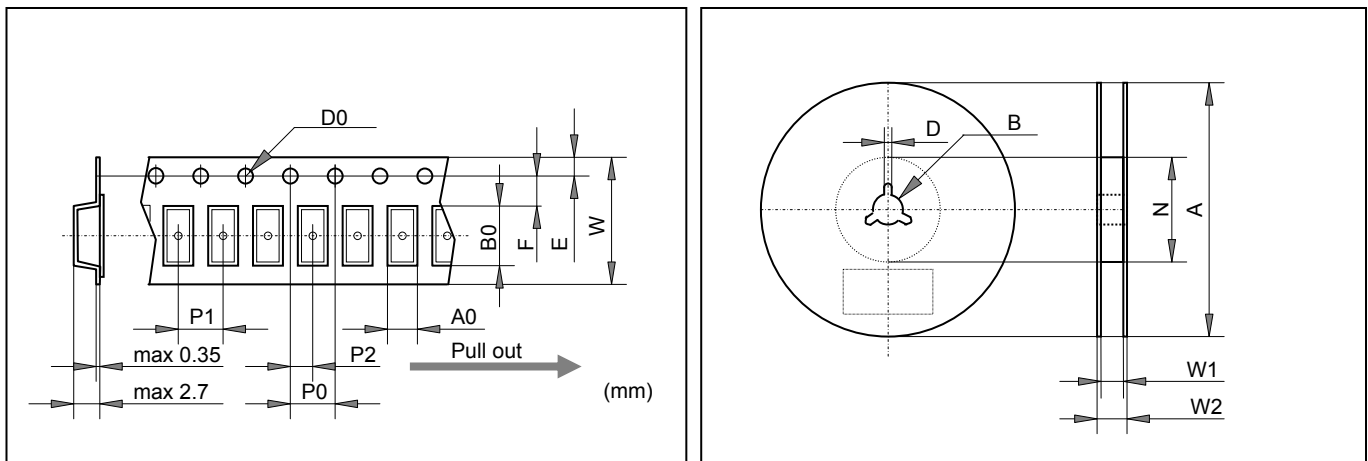

Tape (mm)

Type	A0	B0	W	F	E	P1	P2	P0	D0
NQA18	2.8+/-0.2	3.9+/-0.2	8.0+/-0.3	5.5+/- 005	1.75+/- 0.1	4.0+/- 0.1	2.0+/- 0.05	4.0+/- 0.1	D 1.5+/- 0.1
NQA14	3.45+/- 0.2	5.1+/- 0.2	8.0+/- 0.3	5.5+/- 005	1.75+/- 0.1	8.0+/- 0.1	2.0+/- 0.05	4.0+/- 0.1	D 1.5+/-0.1

Reel (mm)

Type	A	N	B	D	W1	W2	Qty/reel
NQA18	D 178+/- 0.2	Min .D 60	dia13+/- 0.5	2+/- 05	12.4+/- 2.0	Max.18.4	2000pcs
NQA14	D 254+/-0.2	Min. D 80	dia13+/- 0.5	2+/- 05	12.4+/- 2.0	Max.18.4	2000pcs

1/4W, 1/2W, 1W, 2W Power Chip Resistors

RPC14 (1/4W), RPC12 (1/2W),
RPC11 (1W), RPC21 (2W)

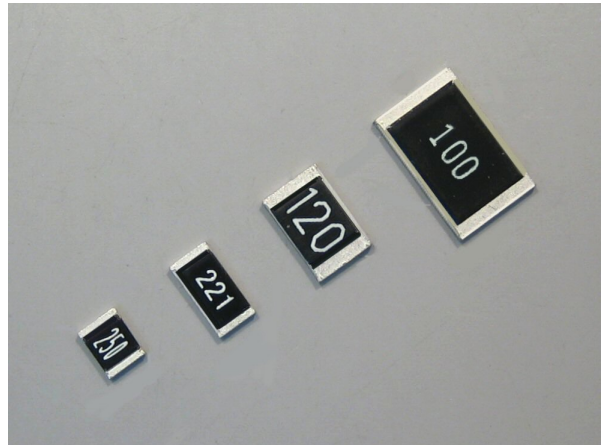

Features and Applications

- Thin film precision chip resistor, 25ppm/°C TC and 0.1% tolerance standard.
- Up to 2W rated power will be realized sufficient derating design.
- Ni-Cr resistor film deposited on alumina ceramic substrate makes wide temperature range operation.
- Industrial measurement, computer, control electronics and ATE.

Dimension Specifications (mm)

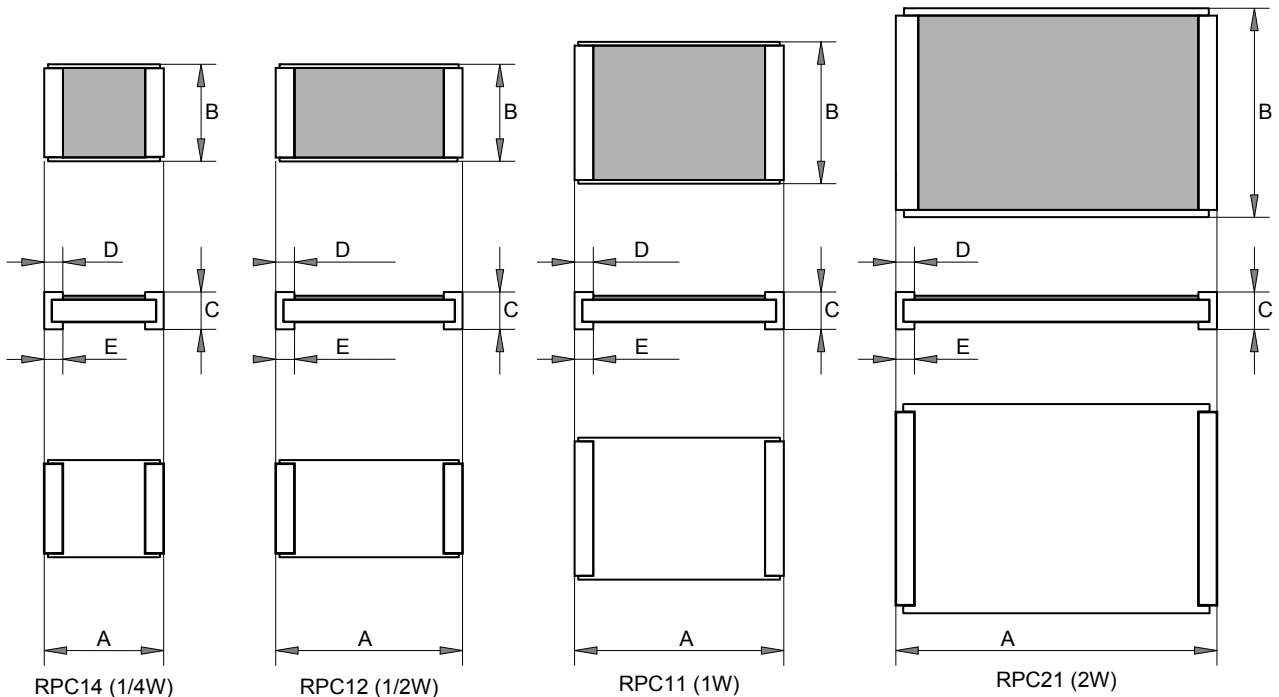

Type	RPC14 (RPC1/4)	RPC12 (RPC1/2)	RPC11 (RPC1)	RPC21 (RPC3)
A (mm)	3.2	5.0	5.7	8.5
B (mm)	2.6	2.5	3.8	5.5
C (mm)	0.7	0.7	0.7	0.7
D (mm)	0.5	0.5	0.5	0.5
E (mm)	0.5	0.5	0.5	0.5

Note: Old p/n changed, such as RPC1/4 to RPC14, because character '/' delete.
Old RPC2(2W) was replaced to RPC3(2W), and RPC3 named RPC21.

1/4W, 1/2W, 1W, 2W Power Chip Resistors
 RPC14 (1/4W), RPC12 (1/2W), RPC11 (1W), RPC21 (2W)

Ordering Information

RPC12	E	100Kohm	B	Z01	Note
RPC14	E (25ppm/K)	E96+	B (0.1%)	Z01	Tape/2000pcs
RPC12	C (50ppm/K)	E24+	F (1.0%)		
RPC11					
RPC21					

Specifications

Power Rating	RPC14, 1/4W	RPC12, 1/2W	RPC11, 1W	RPC21, 2W
TCR	25ppm(E)	25ppm(E)	25ppm(E)	25ppm(E)
Tolerance	1%(B)	1%(B)	1%(B)	1%(B)
Resistance	100-51K	100-51K	100-100K	100-100K
Resistance	E96, E24+	E96, E24+	E96, E24+	E96, E24+
Working Voltages	100VDC or $E = \sqrt{P \cdot R}$			
Operating Temp.	-55 to +155 deg C			
Storage Temp.	-55 to +155 deg C			

Power Rating	RPC14, 1/4W	RPC12, 1/2W	RPC11, 1W	RPC21, 2W
TCR	50ppm(C)	50ppm(C)	50ppm(C)	50ppm(C)
Tolerance	1%(F)	1%(F)	1%(F)	1%(F)
Resistance	10-200K	10-200K	10-1M	10-1M
Resistance	E24+	E24+	E24+	E24+
Working Voltages	100VDC or $E = \sqrt{P \cdot R}$			
Operating Temp.	-55 to +155 deg C			
Storage Temp.	-55 to +155 deg C			

Note: Please request reliability specifications for RPC to factory.

Tape Dimensions (mm)

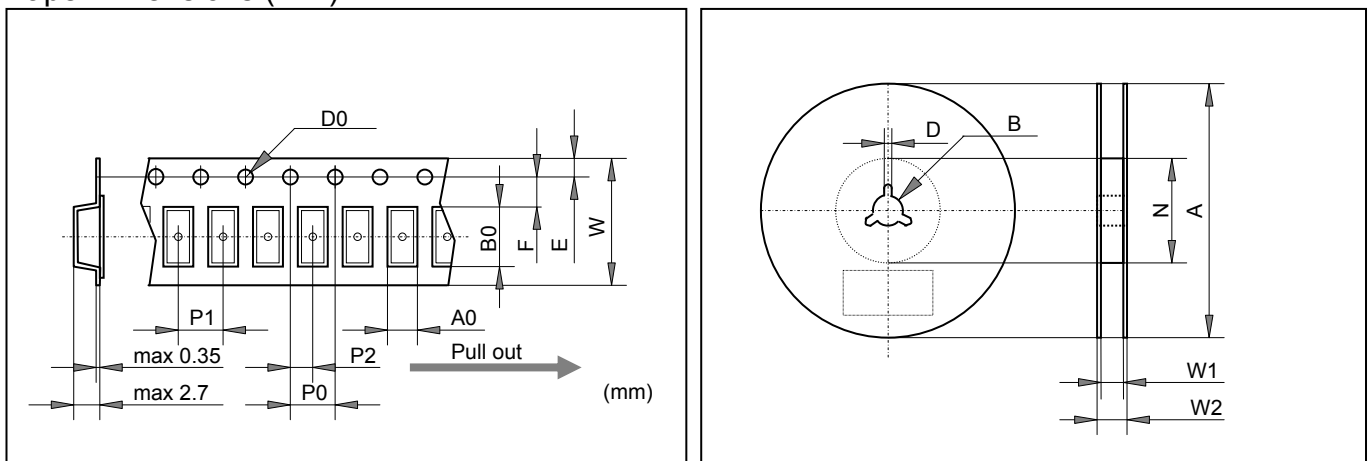

Tape (mm)

Type	A0	B0	W	F	E	P1	P2	P0	D0
RPC14	2.8+/-0.2	3.9+/-0.2	8.0+/-0.3	5.5+/- 005	1.75+/- 0.1	4.0+/- 0.1	2.0+/- 0.05	4.0+/- 0.1	D 1.5+/- 0.1
RPC12	3.45+/- 0.2	5.1+/- 0.2	8.0+/- 0.3	5.5+/- 005	1.75+/- 0.1	8.0+/- 0.1	2.0+/- 0.05	4.0+/- 0.1	D 1.5+/-0.1

Reel (mm)

Type	A	N	B	D	W1	W2	Qty/reel
RPC14	D 178+/- 0.2	Min .D 60	dia13+/- 0.5	2+/- 05	12.4+/- 2.0	Max.18.4	2000pcs
RPC12	D 254+/-0.2	Min. D 80	dia13+/- 0.5	2+/- 05	12.4+/- 2.0	Max.18.4	2000pcs

Note: Please request taping dimensional specification of RPC11 and RPC21 to factory.

Precision Thin Film Chip CAR0402, CAR0603, CAR0805, CAR1206, CAR2010, CAR2512

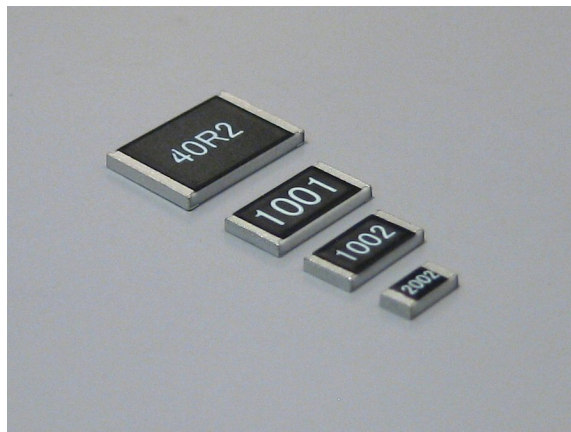

Features and Applications

- Resistances from 1ohm to 3Mohm
- Power Rating 0.0625 to 0.75Watt
- Resistance Tolerances ± 0.01 to $\pm 1\%$
- TCR's ± 50 to $\pm 5\text{ppm}/^\circ\text{C}$
- Size: 0402 / 0603 / 0805 / 1206 / 2010 / 2512

Applications includes industrial measurement, control electronics and automatic test equipment.

Dimensional Specifications (mm)

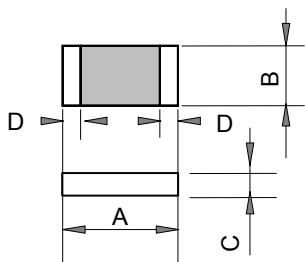

	CAR0402	CAR0603	CAR0805	CAR1206	CAR2010	CAR2512
A	1.00 ± 0.05	1.55 ± 0.10	2.00 ± 0.15	3.05 ± 0.15	4.90 ± 0.15	6.30 ± 0.15
B	0.5 ± 0.05	0.80 ± 0.10	1.25 ± 0.15	1.55 ± 0.15	2.40 ± 0.15	3.10 ± 0.15
C	0.3 ± 0.05	0.45 ± 0.10	0.55 ± 0.10	0.55 ± 0.10	0.55 ± 0.10	0.55 ± 0.10
D	0.2 ± 0.10	0.30 ± 0.20	0.30 ± 0.20	0.42 ± 0.20	0.60 ± 0.30	0.60 ± 0.30

Ordering Information

Type	TCR	Resistance	Tolerance	Packaging
CAR0402	Z (5ppm/ $^\circ\text{C}$)	100 ohm	T (0.01%)	Z01
CAR1216	N (10ppm/ $^\circ\text{C}$)		A (0.05%)	Z00 (Bulk)
CAR2010	D (15ppm/ $^\circ\text{C}$)		B (0.1%)	Z01 (Tape)
CAR2040	E (25ppm/ $^\circ\text{C}$)		C (0.25%)	
CAR2512	C (50ppm/ $^\circ\text{C}$)		D (0.5%)	
CAR4020			F (1%)	
CAR1216HP				
CAR2010HP				
CAR2040HP				
CAR2512HP				
CAR4020HP				

Precision Thin Film Chip

CAR0402, CAR0603, CAR0805, CAR1206, CAR2010, CAR2512

SPECIFICATIONS - STANDARD

Package Size	Power Rating (W) at 70°C	MAX Operating Voltage1	MAX Overload Voltage2	Resistance Range						TCR Ppm/°C
				±0.01%	±0.05%	±0.1%	±0.25%	±0.5%	±1%	
0402	1/16	25V	50V	49.9Ω - 4.99KΩ						±5
				49.9Ω - 12KΩ						±10
				49.9Ω - 12KΩ		49.9Ω - 69.8KΩ				±15
				49.9Ω - 12KΩ		10Ω - 255KΩ				±25
				49.9Ω - 12KΩ		10Ω - 255KΩ		1Ω - 255KΩ		±50
0603	1/16	50V	100V	24.9Ω - 15KΩ						±5
				24.9Ω - 100KΩ		4.7Ω - 332KΩ				±10
				4.7Ω - 332KΩ		4.7Ω - 1MΩ		2Ω - 1MΩ		±15
				4.7Ω - 332KΩ		4.7Ω - 1MΩ		1Ω - 1MΩ		±25
				4.7Ω - 332KΩ		4.7Ω - 1MΩ		1Ω - 1MΩ		±50
0805	1/10	100V	200V	24.9Ω - 30KΩ						±5
				24.9Ω - 200KΩ		4.7Ω - 511KΩ				±10
				4.7Ω - 511KΩ		4.7Ω - 2.49MΩ		1Ω - 2.49MΩ		±15
				4.7Ω - 511KΩ		4.7Ω - 2.49MΩ		1Ω - 2.49MΩ		±25
				4.7Ω - 511KΩ		4.7Ω - 2.49MΩ		1Ω - 2.49MΩ		±50
1206	1/8	150V	300V	24.9Ω - 49.9KΩ						±5
				24.9Ω - 499KΩ		4.7Ω - 1MΩ				±10
				4.7Ω - 1MΩ		4.7Ω - 2.49MΩ		1Ω - 2.49MΩ		±15
				4.7Ω - 1MΩ		4.7Ω - 2.49MΩ		1Ω - 2.49MΩ		±25
				4.7Ω - 1MΩ		4.7Ω - 2.49MΩ		1Ω - 2.49MΩ		±50
2010	1/4	150V	300V	24.9Ω - 100KΩ						±5
				24.9Ω - 499KΩ		4.7Ω - 1MΩ				±10
				4.7Ω - 1MΩ		4.7Ω - 3MΩ		1Ω - 3MΩ		±15
				4.7Ω - 1MΩ		4.7Ω - 3MΩ		1Ω - 3MΩ		±25
				4.7Ω - 1MΩ		4.7Ω - 3MΩ		1Ω - 3MΩ		±50
2512	1/2	150V	300V	24.9Ω - 100KΩ						±5
				24.9Ω - 499KΩ		4.7Ω - 1MΩ				±10
				4.7Ω - 1MΩ		4.7Ω - 3MΩ		1Ω - 3MΩ		±15
				4.7Ω - 1MΩ		4.7Ω - 3MΩ		1Ω - 3MΩ		±25
				4.7Ω - 1MΩ		4.7Ω - 3MΩ		1Ω - 3MΩ		±50

SPECIFICATIONS - HIGH POWER RATING

Package Size	Power Rating (W) at 70°C	MAX Operating Voltage1	MAX Overload Voltage2	Resistance Range						TCR Ppm/°C
				±0.01%	±0.05%	±0.1%	±0.25%	±0.5%	±1%	
0603HP	1/10	75V	150V	24.9Ω - 15KΩ						±5
				24.9Ω - 100KΩ		4.7Ω - 332KΩ		4.7Ω - 332KΩ		±10
				4.7Ω - 332KΩ		4.7Ω - 1MΩ				±15
				4.7Ω - 332KΩ		4.7Ω - 1MΩ				±25
				4.7Ω - 332KΩ		4.7Ω - 1MΩ				±50
0805HP	1/8	150V	300V	24.9Ω - 30KΩ						±5
				24.9Ω - 200KΩ		4.7Ω - 511KΩ		4.7Ω - 511KΩ		±10
				4.7Ω - 511KΩ		4.7Ω - 1MΩ		4.7Ω - 1MΩ		±15
				4.7Ω - 511KΩ		4.7Ω - 1MΩ		1Ω - 1MΩ		±25
				4.7Ω - 511KΩ		4.7Ω - 1MΩ		1Ω - 1MΩ		±50
1206HP	1/4	200V	400V	24.9Ω - 49.9KΩ						±5
				24.9Ω - 499KΩ		4.7Ω - 1MΩ				±10
				4.7Ω - 1MΩ		4.7Ω - 1MΩ				±15
				4.7Ω - 1MΩ		4.7Ω - 1MΩ				±25
				4.7Ω - 1MΩ		4.7Ω - 1MΩ				±50
2010HP	1/3	200V	400V	24.9Ω - 100KΩ						±5
				24.9Ω - 499KΩ		4.7Ω - 1MΩ				±10
				4.7Ω - 1MΩ		4.7Ω - 1MΩ				±15
				4.7Ω - 1MΩ		4.7Ω - 1MΩ				±25
				4.7Ω - 1MΩ		4.7Ω - 1MΩ				±50
2512HP	2/15	200V	400V	24.9Ω - 2KΩ						±10
				24.9Ω - 2KΩ		4.7Ω - 2KΩ		1Ω - 2KΩ		±15
				4.7Ω - 2KΩ		4.7Ω - 2KΩ		1Ω - 2KΩ		±25
				4.7Ω - 2KΩ		4.7Ω - 2KΩ		1Ω - 2KΩ		±25
				4.7Ω - 2KΩ		4.7Ω - 2KΩ		1Ω - 2KΩ		±50

*1 Operating Voltage = or MAX Listed, whichever is lower.

**2 Overload Voltage = 2.5 * or MAX Listed, whichever is lower.

Precision Thin Film Chip
 CAR0402, CAR0603, CAR0805, CAR1206, CAR2010, CAR2512

Environmental Characteristics

Test	Requirement		Conditions
	Tol. < 0.05%	Tol. > 0.05%	
TCR	As Spec.		+25/-55/+25/+125/+25°C
Short Time Overload	$\Delta R \pm 0.05\%$	$\Delta R \pm 0.2\%$	RCWV*2.5 or Max. overload voltage for 5 seconds
	$\Delta R \pm 0.2\%$ for high power rating		
Insulation Resistance	>1000 MΩ		Apply 100VDC for 1 minute
Load Life	$\Delta R \pm 0.05\%$	$\Delta R \pm 0.2\%$	70±2°C, Max. working voltage for 1000 hrs with 1.5 hrs "ON" and 0.5 hrs "OFF"
	>7kΩ $\Delta R \pm 0.5\%$		
	$\Delta R \pm 0.5\%$ for high power rating		
Damp Heat with Load	$\Delta R \pm 0.05\%$	$\Delta R \pm 0.3\%$	40±2°C, 90~95% R.H. Max. working voltage for 1000 hrs with 1.5 hrs "ON" and 0.5 hrs "OFF"
	$\Delta R \pm 0.5\%$ for high power rating		
Bending Strength	$\Delta R \pm 0.05\%$	$\Delta R \pm 0.2\%$	Bending amplitude 3 mm for 10 seconds
Solderability	95% min. coverage		245±5°C for 3 seconds
Resistance to Soldering Heat	$\Delta R \pm 0.05\%$	$\Delta R \pm 0.2\%$	260±5°C for 10 seconds
Thermal Shock	$\Delta R \pm 0.05\%$	$\Delta R \pm 0.25\%$	-55°C~150°C, 100 cycles
Low Temperature Operation	$\Delta R \pm 0.05\%$	$\Delta R \pm 0.2\%$	1 hour, -65°C, followed by 45 minutes of RCWV
	$\Delta R \pm 0.5\%$ for high power rating		

Power Derating Curve

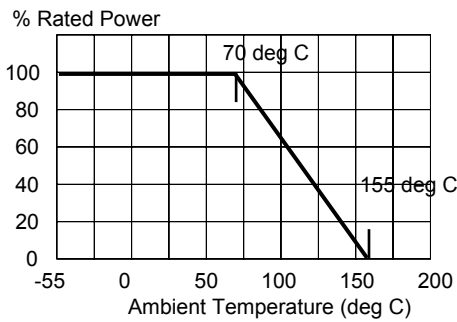

Note

1. The performance of an short time overload test is the specification about one time overload test. Please do not apply the continuous pulse exceeding rated power.
2. When you apply continuous pulse, please care not to exceed the range of a derating curve and not to exceed maximum working voltage and maximum working current.

Precision Thick Film Chip

CRW1210, CRW1216, CRW2010, CRW2040, CRW2512, CRW4020



Features and Applications

- Resistances from 0.1ohm to 100Mohm
- Power Rating 0.35 to 2.0Watt
- Resistance Tolerances to $\pm 0.5\%$
- TCR's to $\pm 50\text{ppm/K}$
- Thick Film Resistance Element
- Size: 1210 / 1216 / 2010 / 2040 / 2512 / 4020

Applications includes industrial measurement, control electronics and automatic test equipment.

Dimensional Specifications (mm)

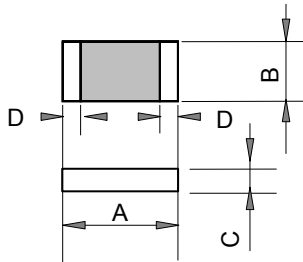

	CRW1210	CRW1216	CRW2010	CRW2040	CRW2512	CRW4020
A	3.2 (+0.2/-0.05)	3.2 (+0.2/-0.05)	5.1 (+0.2/-0.05)	5.1 (+0.2/-0.05)	6.3 (+0.15/-0.05)	10.2 (+0.15/-0.05)
B	2.5 (+0.2/-0.05)	4.1 (+0.2/-0.05)	2.5 (+0.2/-0.05)	10.2 (+0.2/-0.05)	3.5 (+0.2/-0.05)	5.1 (+0.2/-0.05)
C	0.5 (+0.2/-0.1)	0.5 (+0.2/-0.1)	0.6 (+0.2/-0.1)	0.6 (+0.2/-0.1)	0.6 (+0.15/-0.05)	0.6 (+0.15/-0.05)
D	0.8 (± 0.2)	0.8 (± 0.2)	1.2 (± 0.2)	1.2 (± 0.2)	0.9 (± 0.2)	0.9 (± 0.2)

Ordering Information

Type	TCR	Resistance	Tolerance	Packaging
CRW1210	C	100 ohm	F	Z01
CRW1216	C(50ppm/degC)		D (0.5%)	Z00 (Bulk)
CRW2010	A(100ppm/degC)		F (1%)	Z01 (Tape)
CRW2040	H(250ppm/degC)		J (5%)	
CRW2512			K (10%)	
CRW4020				

Minimum quantity Bulk: 100pcs
 Minimum quantity Tape & Reel: 500pcs

Precision Thick Film Chip

CRW1210, CRW1216, CRW2010, CRW2040, CRW2512, CRW4020

Specifications

Type	CRW1210	CRW1216	CRW2010	CRW2040	CRW2512 (M)	CRW4020 (M)
Power Rating (W) ¹	0.35	0.5	0.75	2.0	1.0 / 1.5 ³	2.0
Working Voltage (VAC)	Trimmed	200	200	250	300	500
	Untrimmed (≥5% tol.)	600	600	900	900	1500

Resistance Value(Ω)	Tolerance Available (%)					
	Temperature Coefficients Available (± ppm / °C) ²					
0.1Ω < 1Ω	5 ~ 10% 250	5 ~ 10% 250	5 ~ 10% 250	5 ~ 10% 250	5 ~ 10% 250	5 ~ 10% 250
1Ω < 100Ω	1 ~ 10% 100 / 250	1 ~ 10% 100 / 250	1 ~ 10% 100 / 250	1 ~ 10% 100 / 250	1 ~ 10% 100 / 250	1 ~ 10% 100 / 250
100Ω < 100M	1 ~ 10% 50 / 100	1 ~ 10% 50 / 100	1 ~ 10% 50 / 100	1 ~ 10% 50 / 100	0.5 ~ 10% 50 / 100	0.5 ~ 10% 50 / 100

¹ W @ 70 °C / 0W @ 155 °C² 50 ppm: +25 °C to +125 °C³ Structure (M) with higher working voltage

Specification	Value
Temperature Range	- 55°C to + 155°C
Climactic Category	55 / 155 / 56
Solderability	250°C / 3s
Max. Soldering Temperature	260°C / 10 s

Long Term Stability	Max ΔR	
	< 10Ω	10Ω – 100M
Storage 125°C / 1000h	± 1%	± 0.5%
Storage 155°C / 1000h	± 2%	± 1%
Load Life / P =70% / 70°C 1000h	± 2%	± 1%
Short term overload	± 0.5%	± 0.25%
Humidity / 96%RH / 40°C / 56 days	± 1%	± 0.5%

Power Derating

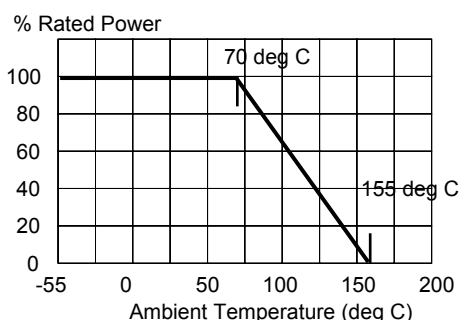

Note

1. The performance of an short time overload test is the specification about one time overload test. Please do not apply the continuous pulse exceeding rated power.

2. When you apply continuous pulse, please care not to exceed the range of a derating curve and not to exceed maximum working voltage and maximum working current.

20170301

Current Shunt Thick Film Chip
 CLSA0402, CLSA0603, CLSA0805,
 CLSA1206, CLSA2010, CLSA2512



Features and Applications

- Resistances from 20m Ω to 1.0 Ω
- Power Rating 0.0625W to 2 W
- Resistance Tolerances to ± 1%, ± 5%
- TCR's to ± 100 ppm/K to 200 ppm/K
- Thick Film Resistance Element
- Size: 0402 / 0603 / 0805 / 1206 / 2010 / 2512.
- Alumina substrate for heat radiation.
- Applications includes industrial measurement, control electronics and automatic test equipment.

Dimension Specifications (mm)

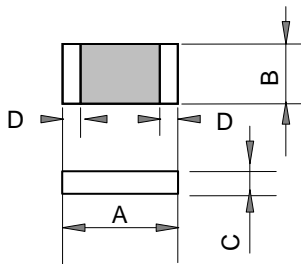

Power Derating

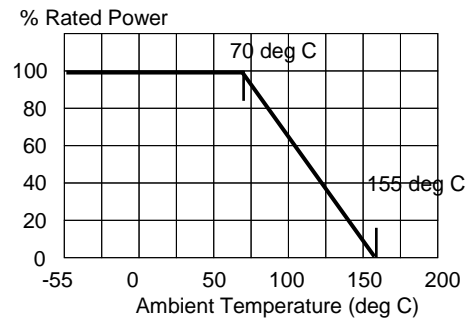

mm (inch)	CLSA0402	CLSA0603	CLSA0805	CLSA1206	CLSA2010	CLSA2512
Power Rating (W)	0.0625	0.1	0.125	0.25	0.75	1.0
Resistance, Min.(Ω)	0.05	0.02	0.02	0.01	0.01	0.01
Resistance, Max. (Ω)	1.0	1.00	1.00	1.00	1.00	1.00
TCR (ppm/K)	200 - 400	200 - 600	200 - 600	200 - 600	200 - 600	200 - 600
Tolerance	1%, 5%	1%, 5%	1%, 5%	1%, 5%	1%, 5%	1%, 5%
Operating Temp (°C)	-55 to +155	-55 to +155	-55 to +155	-55 to +155	-55 to +155	-55 to +155
A	1.00(0.04)	1.60 (0.06)	2.00 (0.08)	3.10 (0.12)	5.00 (0.20)	6.30 (0.25)
B	0.50(0.02)	0.80 (0.03)	1.25 (0.04)	1.55 (0.06)	2.50 (0.10)	3.10 (0.12)
C	-----	-----	-----	-----	-----	-----
D	-----	-----	-----	-----	-----	-----
Packaging (pcs) T&R	10,000	5,000	5,000	5,000	4,000	4,000

Ordering Information

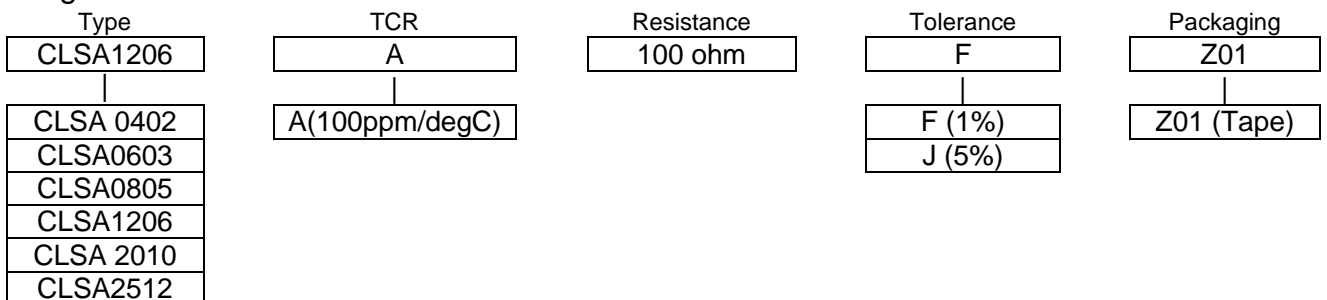

Current Shunt Thick Film Chip

1210, 1216, 2010, 2040, 2512, 4020

Environmental Characteristics

Test	Requirement	Test Method
Temperature Coefficient of Resistance	As Spec.	-55°C to 125°C, 25°C reference temperature
Short Time Overload	±0.5%+0.05Ω	RCWV*2.5 or Max. overload voltage for 5 seconds
Insulation Resistance	>10G Max.	overload voltage for 1 minute
Load Life	±1.0%+0.05Ω	70±2°C, Max. working voltage for 1000 hrs with 1.5 hrs "ON" and 0.5 hrs "OFF"
Biased Humidity	±1.0%+0.05Ω	1000hrs 85°C/85% RH 10% of operating power
High Temperature Exposure	±0.5%+0.05Ω	at +155°C for 1000 hrs
Bending Strength.	As Spec	Bending once for 5 seconds with 3mm
Thermal Shock	±0.5%+0.05Ω	-55°C/+155°C. 300 cycles with maximum transfer time of 20 seconds. Dwell time 15 minutes air to air
Solderability	95% min. coverage	245±5°C for 3 seconds
Resistance to Soldering Heat	±0.5%+0.05Ω	260±5°C for 10 seconds
Voltage Proof	No breakdown or flashover	1.42 times RCWV (RMS) for 1 minute
Leaching	Individual leaching area <5% Total leaching area <10%	260±5°C for 30 seconds
Temperature Cycling	±0.5%+0.05Ω	-55°C to +125°C, 1000 cycles
Moisture Resistance	±1.0%+0.05Ω	24hrs/cycle
Mechanical Shock	±0.25%+0.05Ω	Wave form: Tolerance for half sine pulse Peak value of 100g's. Normal Duration (D) is 6
Vibration	±0.5%+0.05Ω	5 g's for 20 min., 12 cycles each of 3 orientations, 10-2000Hz
ESD	±1.0%+0.05Ω	Human body, 2KV
Flame Retardance	No Flame Present	Temperature sensing at 500°C, voltage power subjected to 32VDC current clamped up to 500ADC and decreased in 1.0VDC/hour
Resistance to Solvents	Marking Unsmearred	Add Aqueous wash chemical - OKEM Clean or equivalent. Do not use banned solvents.
Terminal Strength	Not broken	Force of 1.8kg for 60 seconds

High Resistance Chip resistors, CHR

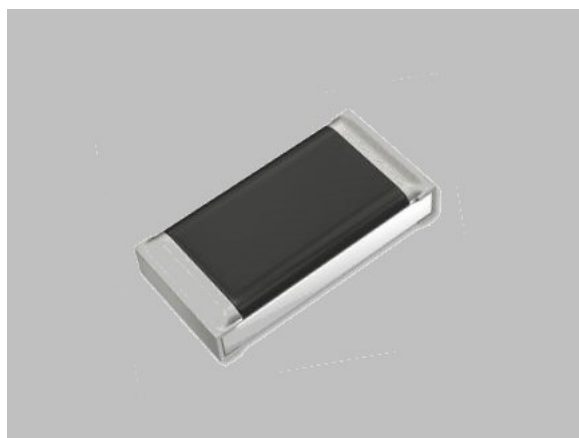

Features

1.0Ω to 10MΩ high resistance chip resistors and power rating 0.05W to 2.0W produced by thick film technology. Non magnetic and Tin free terminal material eliminates whisker problem and suitable for gluing or soldering. Wide size variation 0402, 0603, 0805, 1206, 2512, 4020 helps circuit design. Applications include high voltage power sources, high voltage pulse generators for medical and industrial equipments.

Dimensions

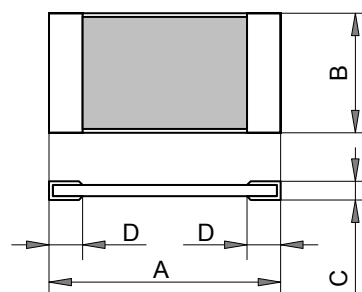

Dimensions

(mm)	(mm)	A	B	C	D
CHR 0402	CHR 0402H	0.95 +0.10 / 0.05	0.48 +0.10 / -0.05	0.28 +0.10 / -0.05	0.10 +0.1 / -0.05
CHR 0805	CHR 0805H	1.50 +0.15 / 0.05	0.80 +0.15 / -0.05	0.40 +0.15 / -0.05	0.20 +0.2 / -0.1
CHR 2010	CHR 2010H	2.00 +0.15 / 0.05	1.25 +0.15 / -0.05	0.40 +0.15 / -0.05	0.30 +0.2 / -0.1
CHR 4020	CHR 4020H	3.20 +0.15 / 0.05	1.50 +0.20 / -0.05	0.40 +0.15 / -0.05	0.30 +0.2 / -0.1
CHR 0402	CHR 0402H	5.10 +0.15 / 0.05	2.50 +0.20 / -0.05	0.60 +0.20 / -0.1	1.20 +/-0.2
CHR 0805	CHR 0805H	6.30 +0.15 / 0.05	3.50 +0.20 / -0.05	0.60 +0.15 / -0.05	0.90 +/-0.2
CHR 2010	CHR 2010H	10.2 +0.15 / 0.05	5.10 +0.20 / -0.05	0.60 +0.15 / -0.05	0.90 +/-0.2

Specifications, Type, Power Rating, Working Voltage, Resistance Range, Tolerance, TCR, VCR

Type	Power Rating (W) (4)	Working Volt. (V) (2) Trimmed	Working Volt (V) (2) untrimmed	Resistance Range Tolerance available (%) TCR available (+/- ppm/°C) (1)			
				1.0Ω-<10Ω	10Ω-<100Ω	100Ω-1MΩ	>1MΩ-10MΩ
0402 (4)	0.05	30	60	10% to 20% 250	5% to 10% 100	1% to 10% 50/100	5% to 20% 50,100
0603 (4)	0.10	75	150	5% to 20% 100, 250	2% to 10% 50,100	1% to 10% 50, 100	1% to 10% 50, 100
0805 (4)	0.125	100	200	5% to 20% 100, 250	1% to 10% 50,100	0.5% to 10% 50,100	1% to 10% 50, 100
1206	0.25	200	400	5% to 20% 100, 250	1% to 10% 50,100	0.5% to 10% 50,100	1% to 10% 50, 100
2010	0.50	250	900	5% to 20% 100, 250	1% to 10% 50,100	0.5% to 10% 50,100	1% to 10% 50, 100
2512	1.00(3)	300	1200	5% to 20% 100, 250	1% to 10% 50,100	0.5% to 10% 50,100	1% to 10% 50, 100
4020	2.00(3)	500	1200	5% to 20% 100, 250	1% to 10% 50,100	0.5% to 10% 50,100	1% to 10% 50, 100

High Resistance Chip resistors, CHR

Ordering Information

Type	Resistance	Tolerance	TCR	Package
CHR1206H	10Mohm	1%	50ppm/K	Z01
CHR0402 / H	Please see table	Please see table	Please see table	Z00 (Bulk)
CHR0603 / H				Z01 (Tape and reel)
CHR0805 / H				
CHR1206 / H				
CHR1210 / H				
CHR2512 / H				
CHR4020 / H				

Specifications

Specifications	Value	
Temperature Range	-55°C to +155°C (standard), -55°C to +125°C (50ppm/°C parts), TCR valid +25°C to +125°C	
Climatic Category	+55°C / +155°C / +56°C	
Solderability	250°C, 3 seconds (up to 6 months after shipment or 12 months at storage in Nitrogen)	
Max. Soldering Temperature	260°C, 10 seconds	
Long Term Stability	Maximum R	
	<10 ohm	10ohm – 10Mohm
Storage 125°C, 1000hours	+/-1%	+/-0.5%
Storage 155°C, 1000hours	+/-2%	+/-1.0%
Load Life 70 °C, 1000hours	+/-0.5%	+/-0.5%
Short time Overload	+/-0.5%	+/-0.25%
Maximum Voltage, 1000hours	+/-1.0%	+/-0.5%
RoHS	This parts is RoHS compliance with exemption 7(C), as authorized by 2011/65/EU	

Derating (standard)

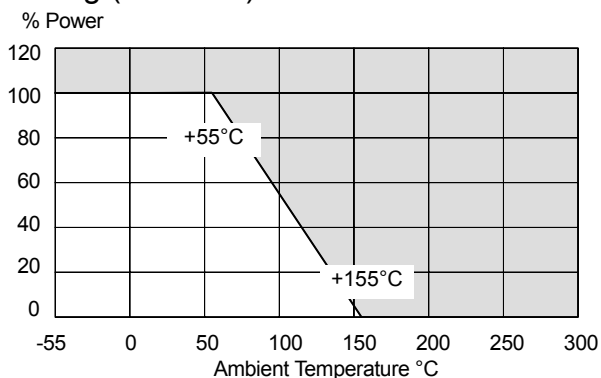

Derating (H version)

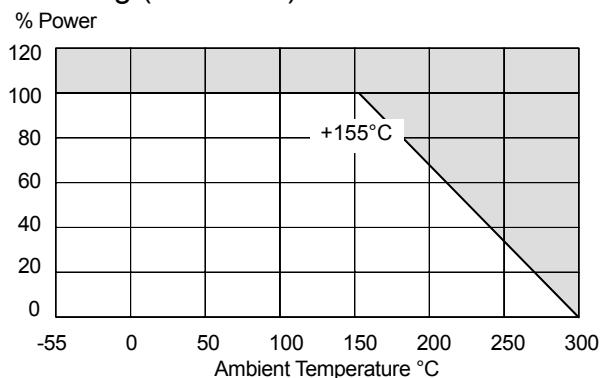

Packaging

Tape width 8mm / Reel diameter 180mm and 330mm.

Minimum quantity bulk 100pieces per value.

30pieces per value for size2512 and 4020

Minimum quantity Tape & Reel / 500 pieces per value. Except size 0402 / 1000 pieces per value.

Note for specifications

- (1) TCR in ppm/°C: TCR below standard TCR (heist value), +25 °C to +85°C.
- (2) Continuous operating voltage $V \leq \sqrt{PxR}$ or maximum working voltage (the lower value).
- (3) Solder pads must be sufficiently large to keep resistor's peak temperature below rating
- (4) Best tolerance for high temperature version is 2%.

TO126 10W PRECISION POWER RESISTORS
RNP-10P

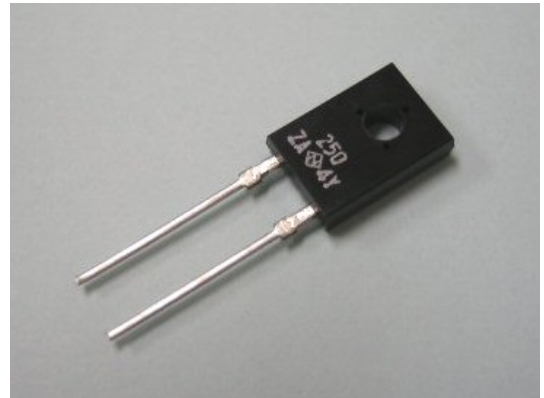

Features and Applications

0.1% accuracy, 5ppm/C TCR, TO126 style high precision high power resistors.
 Now the precision series has been released. 10W rating power when attaching to metal case or heat-sink. RNP20P has proportional temperature vs. small resistance change between -55 to +120 deg C because of use of thin film, and no use of bulk metal resistance.
 Non inductive and non capacitive impedance characteristic realized in range of DC to 100MHz.
 2KV withstanding voltage between circuit and flange. Program-able precision voltage power supply, program precision current power supply, program high frequency power supply, program low distortion AC power supply, testing inspection equipment for power semiconductors and the other inverters, UPS, motor control, electronic load, high frequency power supply, high frequency amplifiers, 50ohm termination, adjustment resistor for high frequency, Wilkinson amplifier, etc.

Dimensions (mm)

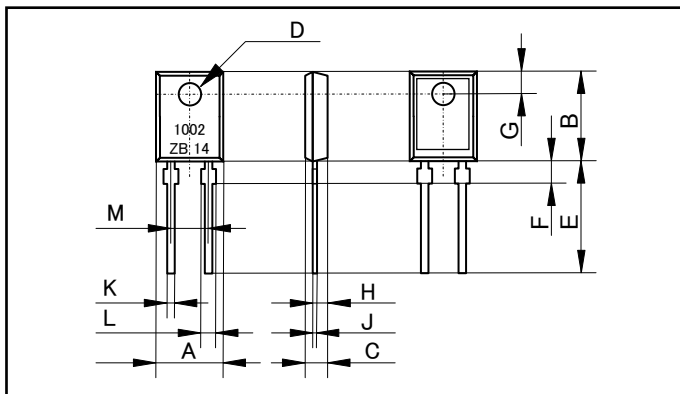

	mm	mm
A	8.5	+/-0.2
B	12.0	+/-0.2
C	3.1	+/-0.2
D	3.1	+/-0.1
E	17.0	+/-1.0
F	3.2	+/-0.5
G	3.8	+/-0.2
H	1.75	+/-0.1
J	0.5	+/-0.05
K	0.6	+/-0.05
L	1.4	+/-0.05
M	5.08	+/-0.1

Ordering Information

Type	TCR	Resistance	Tolerance	Code	PE Tube
RNP-10P	Z	1R25	B	Z00	
RNP-10P	Z (5ppm/K)	E24+, E96	B (0.1%)	Z00	

Resistance Value, E24+ & E96

1.00	1.02	1.05	1.07	1.10	1.13	1.15	1.18	1.20	1.21	1.24	1.27	1.30	1.33	1.37	1.40	1.43	1.47	1.50	1.54
1.58	1.60	1.62	1.65	1.69	1.74	1.78	1.80	1.82	1.87	1.91	1.96	2.00	2.05	2.10	2.15	2.20	2.21	2.26	2.32
2.37	2.40	2.43	2.49	2.50	2.55	2.61	2.67	2.70	2.74	2.80	2.87	2.94	3.00	3.01	3.09	3.16	3.24	3.30	3.32
3.40	3.48	3.57	3.60	3.65	3.74	3.83	3.90	3.92	4.02	4.12	4.22	4.30	4.32	4.42	4.53	4.64	4.70	4.75	4.87
4.99	5.00	5.10	5.11	5.23	5.36	5.49	5.60	5.62	5.76	5.90	6.04	6.19	6.20	6.34	6.49	6.65	6.80	6.81	6.98
7.15	7.32	7.50	7.68	7.87	8.06	8.20	8.25	8.45	8.66	8.87	9.09	9.10	9.31	9.53	9.76				

TO126 10W PRECISION POWER RESISTORS

RNP-10P

Specifications

Items	Specifications	Notes
Resistance Range	1 ohm – 51 k ohm	
TCR	+/-5 ppm/degree C (Z)	
Tolerance	+/-0.1% (B),	
Nominal Resistance	E24+, E96	
Operation Temp. Range	-55C to +120 degree C	
Rating Power Temp	+25 degree C	
Rating Power	10 Watt	At -55 to 25 deg C flange temperature
Derating Rating Power	5 Watt	At -55 to 25 C flange temperature
Heat Resistance	5.9 degree C/W	Hot spot to flange
Max. Operating Volt.	500V or $\sqrt{P \cdot R}$	
Inductance	10nH	At stand-off
Capacitance	1pF	At stand-off

Performances

	Performances	Conditions
Withstanding Volt.	AC2000 Volt	60 seconds.
Insulation Resistance	Over 1,000 Meg ohm	Between terminals and flange.
Short Time Overload	+/- (0.25 %)	Rating power*2.5, 5 seconds, with heat sink
Temp. Cycle	+/- (0.25 %)	-55 C,30 min.,+120 C,30 min., 5cycles
Humidity	+/- (1.0 %)	40C, 90-95%RH, DC 0.1W, 1000 hours.
Load Life	+/- (1.0 %)	25 C, 90 min. ON, 30 min. OFF, 1000 hours.
Soldering Heat	+/- (0.1 %)	350+/-5 C, 3seconds,
Solder ability	Over 3/4 of surface	230+/-5 C, 3seconds.
Vibration	+/- (0.25 %)	JISC5202
Terminal Strength	+/- (0.25 %)	Tension 4.9N, 1-5 sec. Bend 2.45N, 90degree, 2 times.

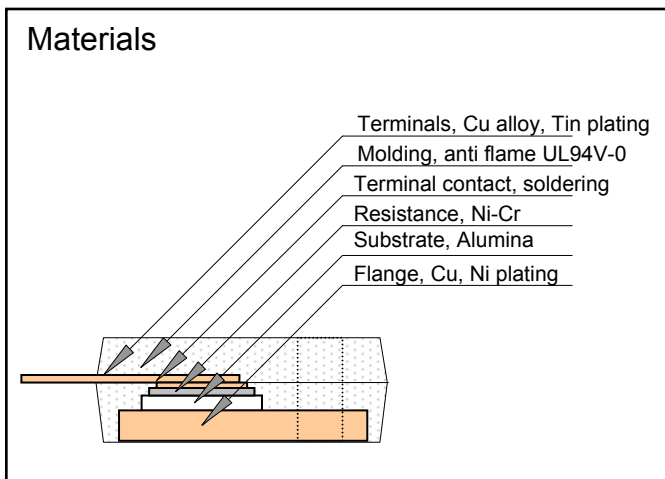
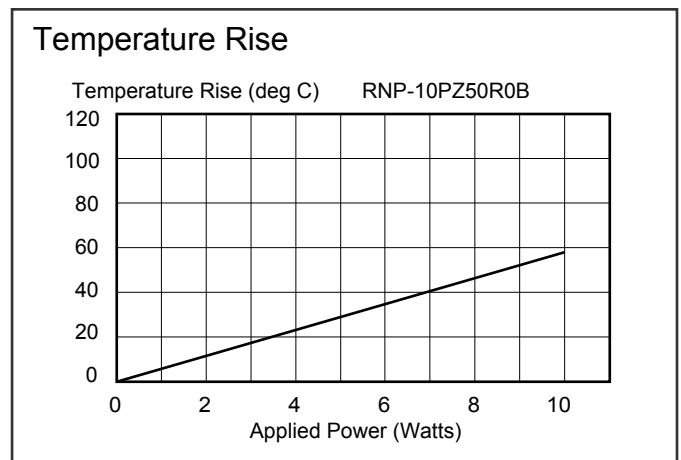
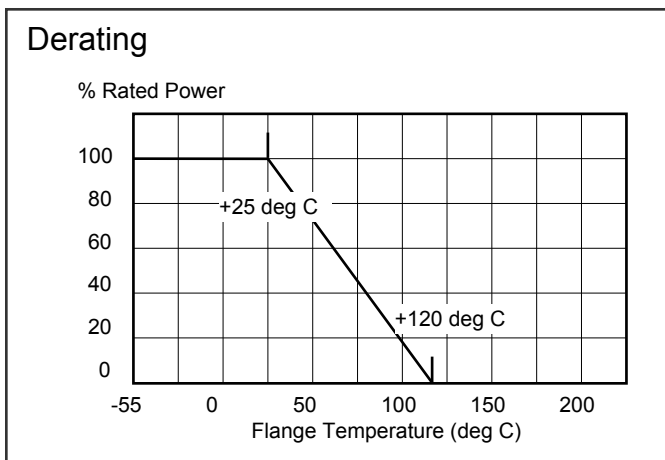

Notes

(1) Flange and resistor has insulated inside, when you attach flange to electric device metal case, please attach directly with screw stop.

TO220 10W PRECISION POWER RESISTORS RNP-20P

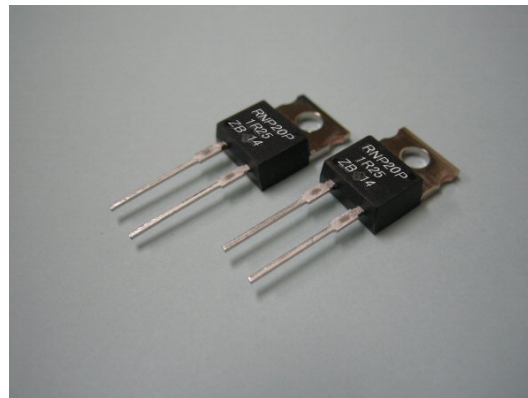

Features and Applications

0.1% accuracy, 5ppm/C TCR, TO220 style high precision high power resistors. The famously advanced TO220 resistors were produced by Nikkohm and were the worlds fastest in 1985.

Now the precision series has been released. 10W rating power when attaching to metal case or heat-sink. RNP-20P has proportional temperature vs. small resistance change between -55 to +120 deg C because of use of thin film, and no use of bulk metal resistance.

Non inductive and non capacitive impedance characteristic realized in range of DC to 100MHz.

2KV withstanding voltage between circuit and flange. Program-able precision voltage power supply, program precision current power supply, program high frequency power supply, program low distortion AC power supply, testing inspection equipment for power semiconductors and the other inverters, UPS, motor control, electronic load, high frequency power supply, high frequency amplifiers, 50ohm termination, adjustment resistor for high frequency, Wilkinson amplifier, etc.

Dimensions (mm)

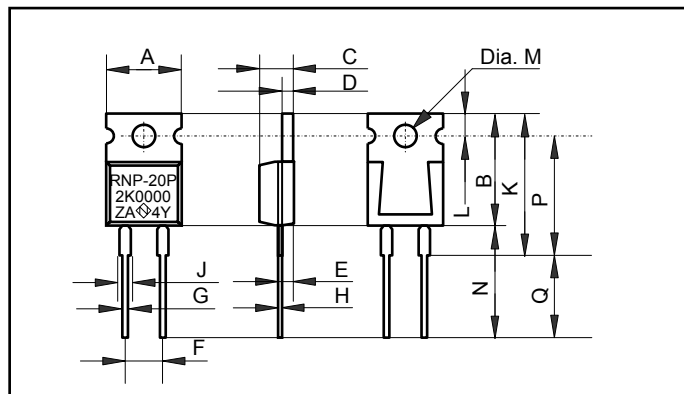

Symbol	(mm)
A	10.1+/-0.2
B	15.0+/-0.2
C	4.5+/-0.2
D	1.5+/-0.1
E	2.45+/-0.2
F	5.08+/-0.5
G	0.75
H	0.50
J	1.5
K	19.0
L	2.7+/-0.5
M	3.6 dia.
N	15.0 min.
P	16.0+/-0.5
Q	11.0 min.

Ordering Information

Type	TCR	Resistance	Tolerance	Code	Note
RNP-20P	Z	1R25	B	Z00	PE Tube
RNP-20P	Z (5ppm/K)	E24+, E96	B (0.1%)	Z00	

Resistance Value, E24+ & E96

1.00	1.02	1.05	1.07	1.10	1.13	1.15	1.18	1.20	1.21	1.24	1.27	1.30	1.33	1.37	1.40	1.43	1.47	1.50	1.54
1.58	1.60	1.62	1.65	1.69	1.74	1.78	1.80	1.82	1.87	1.91	1.96	2.00	2.05	2.10	2.15	2.20	2.21	2.26	2.32
2.37	2.40	2.43	2.49	2.50	2.55	2.61	2.67	2.70	2.74	2.80	2.87	2.94	3.00	3.01	3.09	3.16	3.24	3.30	3.32
3.40	3.48	3.57	3.60	3.65	3.74	3.83	3.90	3.92	4.02	4.12	4.22	4.30	4.32	4.42	4.53	4.64	4.70	4.75	4.87
4.99	5.00	5.10	5.11	5.23	5.36	5.49	5.60	5.62	5.76	5.90	6.04	6.19	6.20	6.34	6.49	6.65	6.80	6.81	6.98
7.15	7.32	7.50	7.68	7.87	8.06	8.20	8.25	8.45	8.66	8.87	9.09	9.10	9.31	9.53	9.76				

TO220 10W PRECISION POWER RESISTORS

RNP-20P

Specifications

Items	Specifications	Notes
Resistance Range	1 ohm – 51 k ohm	
TCR	+/-5 ppm/degree C (Z)	
Tolerance	+/-0.1 % (B),	
Nominal Resistance	E24+, E96	
Operation Temp. Range	-55C to +120 degree C	
Rating Power Temp	+25 degree C	
Rating Power	10 Watts	At -55 to 25 C flange temperature
Derated Rating Power	5 Watts	At -55 to 25 C flange temperature
Heat Resistance	3.3 degree C/W	Hot spot to flange
Max. Operating Volt.	500V or $\sqrt{P \cdot R}$	
Inductance	10nH	At stand-off
Capacitance	1pF	At stand-off

Performances

	Performances	Conditions
Withstanding Volt.	AC2000 Volt	60 seconds.
Insulation Resistance	Over 1,000 Meg ohm	Between terminals and flange.
Short Time Overload	+/- (0.25 %)	Rating power*2.5, 5 seconds, with heat sink
Temp. Cycle	+/- (0.25 %)	-55 C,30 min., +120 C,30 min., 5cycles
Humidity	+/- (1.0 %)	40C, 90-95%RH, DC 0.1W, 1000 hours.
Load Life	+/- (1.0 %)	25 C, 90 min. ON, 30 min. OFF, 1000 hours.
Soldering Heat	+/- (0.1 %)	350+/-5 C, 3seconds,
Solder ability	Over 3/4 of surface	230+/-5 C, 3seconds.
Vibration	+/- (0.25 %)	JISC5202
Terminal Strength	+/- (0.25 %)	Tension 4.9N, 1-5 sec. Bend 2.45N, 90degree, 2 times.

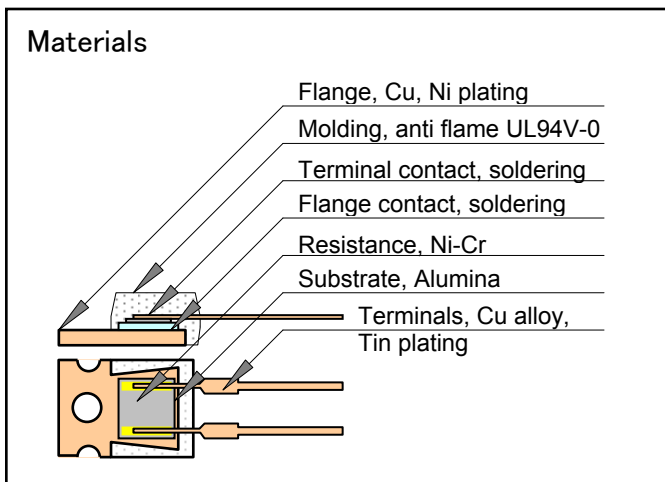
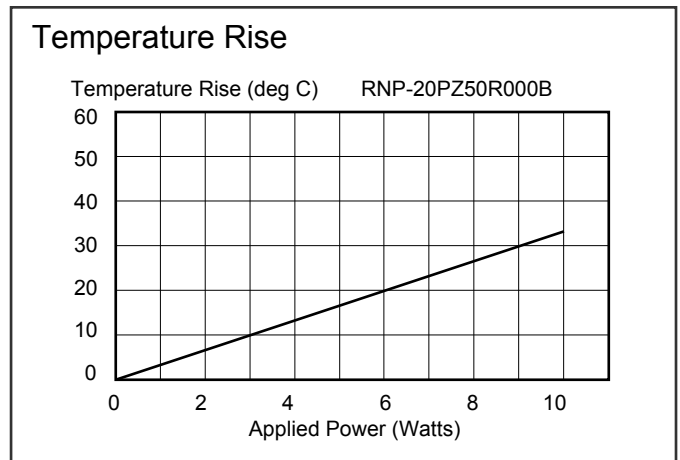
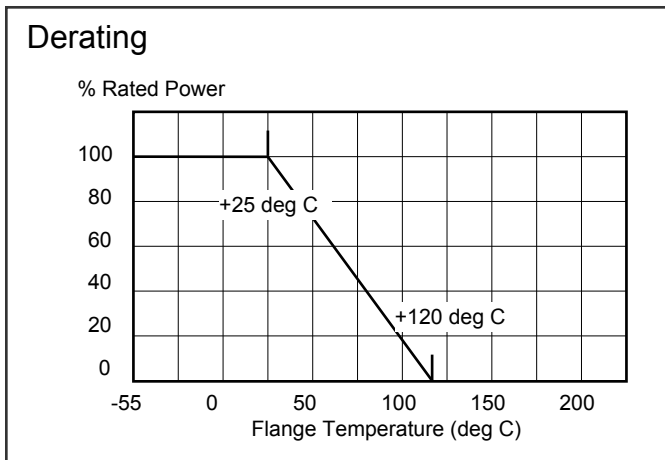

Notes

(1) Flange and resistor has insulated inside, when you attach flange to electric device metal case, please attach directly with screw stop.

CHIP RESISTOR NETWORKS
SOIC TYPE
MCM4, MCM8, MCM16

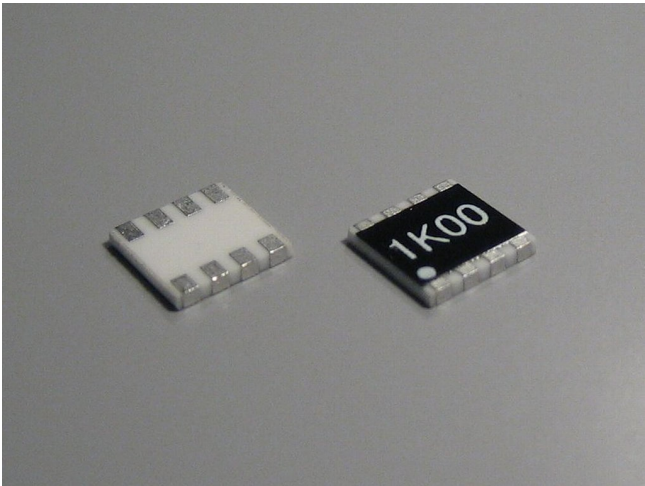

Features and Applications

- 1ppm/C tracking and 0.01% ratio precision NiCr thin film resistor networks.
- 50mW/resistor rating sufficient power derating for 5 volt analog circuits.
- Simple standard circuits for 8pin available to satisfy flexible circuit design requirements.
- Supplied in plastic tape reel for automated assembling.
- Custom designed circuits also available in 8pin configuration. Customer service will be advised.
- Measurement, industrial electronics, industrial instruments, automatic testing, high-speed digital data transmission, intelligent hubs and routers, and data switching.

Dimensions (mm) Pin Configuration Foot Pattern

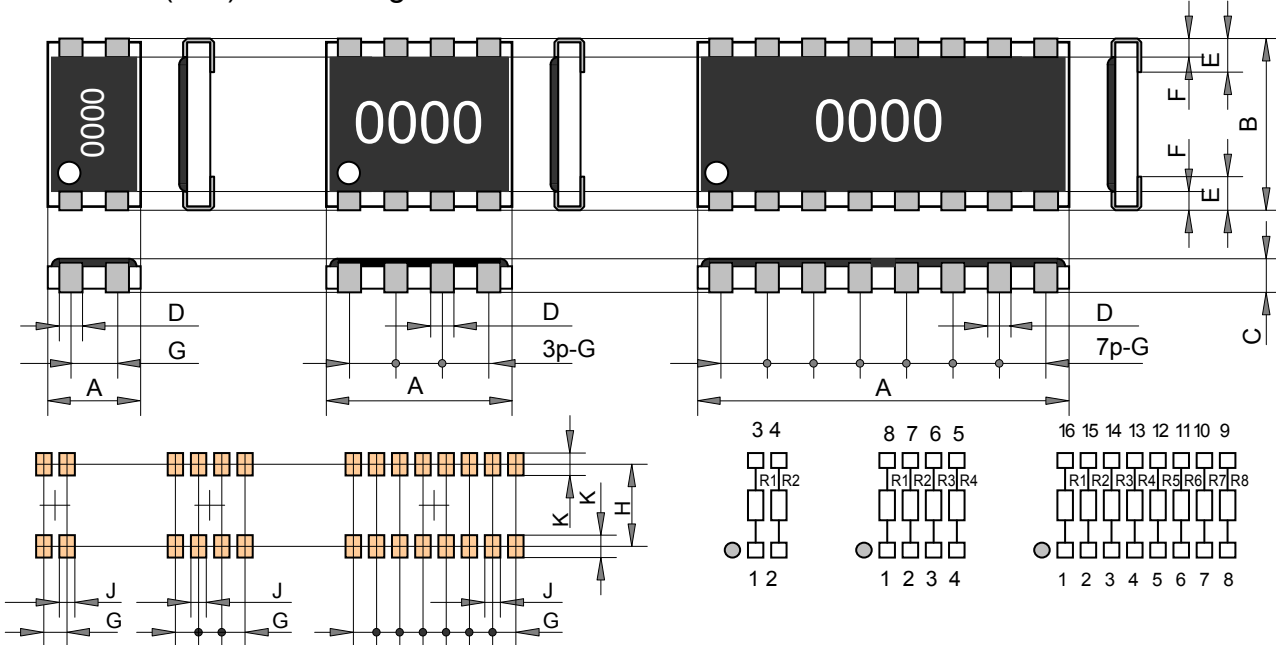

	A	B	C	D	E	F	G	H	J	K
MCM4	3.00 +/-0.2	5.00 +/-0.1	0.80 +/-0.2	0.635 +/-0.1	1.00 +/-0.2	(0.5)	1.27 +/-0.1	4.00	0.635 +/-0.1	1.00
MCM8	5.00 +/-0.2	5.00 +/-0.1	0.80 +/-0.2	0.635 +/-0.1	1.00 +/-0.2	(0.5)	1.27 +/-0.1	4.00	0.635 +/-0.1	1.00
MCM16	10.00 +/-0.2	5.00 +/-0.1	0.80 +/-0.2	0.635 +/-0.1	1.00 +/-0.2	(0.5)	1.27 +/-0.1	4.00	0.635 +/-0.1	1.00

MCM4, MCM8, MCM16

Ordering Information

Type	TCR	Resistance	Tol.	Package
MCM8	T(5ppm-2ppm)	10kohm	Q(0.1%-0.01%)	Z00
MCM4	Z (5 ppm/C)	E24 & E96	A (0.05%)	Z00(Bulk)
MCM8	P (10ppm/C)		Q (0.01%)	Z01(Tape)
MCM16	Q (5 ppm/C)		R (0.02%)	
MCM4-00	R (1 ppm/C)		S (0.05%)	
MCM8-00	S (5 ppm/C)		T (0.10%)	
MCM16-00	T (2 ppm/C)			

Note: When MCM8 T 10kohm Q Z00, R1=R2=R3=R4=10kohm Tracking 2ppm/deg C, matching: 0.01% at -20 deg C to +120 deg C

Matching Tracking Notation

	TCR	Tracking
P	+/-50 ppm/deg C	10 ppm/deg C
Q	+/-10 ppm/deg C	5 ppm/deg C
R	+/-5 ppm/deg C	1 ppm/deg C
S	+/-25 ppm/deg C	5 ppm/deg C
T	+/-5 ppm/deg C	2 ppm/deg C

	Tolerance	Ratio
P	+/-0.05%	0.01%
Q	+/-0.1%	0.01%
R	+/-0.1%	0.02%
S	+/-0.1%	0.05%
T	+/-0.1%	0.10%

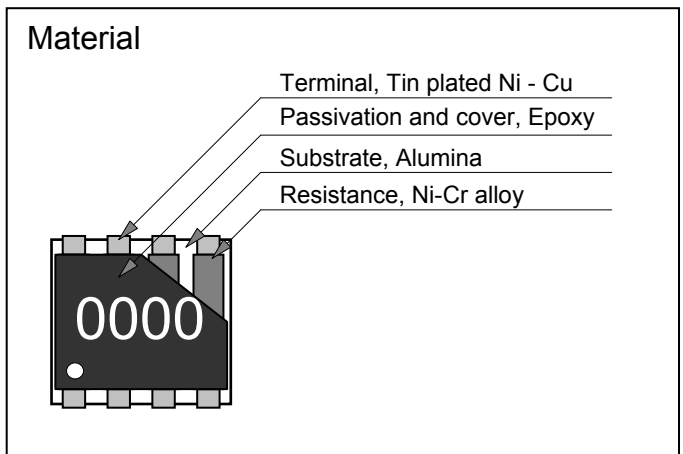
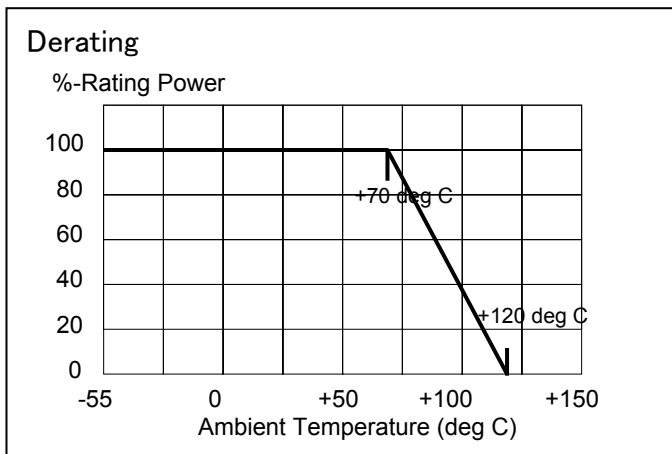

Performances

Type	MCM	Note
Resistance Range (ohm)	100 ohm - 22Kohm	E24+ and E96
Standard Resistance	100ohm 1Kohm 10Kohm	Same resistance
TC-Absolute	+/-5ppm/deg C	-20 deg C to +120 deg C
TC-Tracking	+/-1ppm/deg C	-20 deg C to +120 deg C
Tolerance-Absolute	+/-0.05%	-20 deg C to +120 deg C
Tolerance-Matching	+/-0.01%	-20 deg C to +120 deg C
Rating Power/Resistor	50 mW	
Rating Power/Package	0.2 W	
Max. Operating Volt.	$\sqrt{P \cdot R}$ or 80 V	
Rating Temp.	+70°C	
Operating Temp. Range	-55 to +120 deg C	
Storage Temp. Range	-55 to +120 deg C	

Electrical Specifications

Items	Specifications	Conditions
Short Time Overload	+/- (0.05%) absolute	2.5 times rating power, 5 seconds
Insulation Resistance	>10,000Mohm	
Withstand Voltage	+/- (0.05%) absolute	100V, 60 seconds
Heat Shock	+/- (0.1%) absolute	5 cycles for temp. -65, +25, +125, +25 deg C
Soldering Heat	+/- (0.05%) absolute	350 deg C, 3 seconds
Solder ability	Covered 95% area	230 deg C, 3 seconds
Solvent	No mechanical damage	
Humidity	+/- (0.1%) absolute	40 deg C, 90-95RH, DC 0.1W, 1000hours
Load Life	+/- (0.1%) absolute	70 deg C, 90min.ON, 30min.OFF, 1000hours

SOP RESISTOR NETWORKS

MC8, MC16, MC20

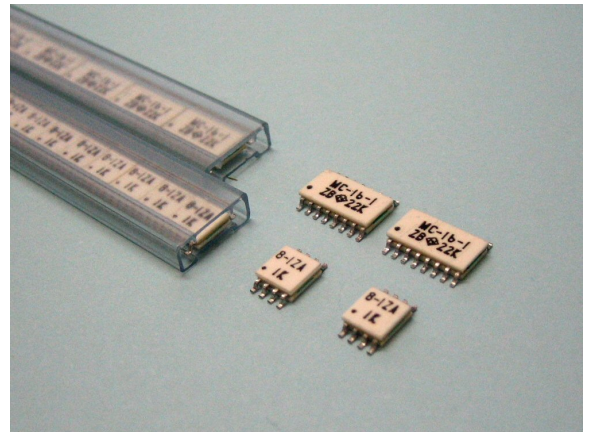

Features and Applications

- 5ppm/C TCR and 0.05% tolerance standard super precision Ni-Cr thin film resistor networks.
- 50mW/resistor rating sufficient power derating for 5-15 volt swinging circuits.
- Simple standard circuits for 8 pins, 16 pins and 20 pins available to satisfy flexible circuit design requirements.
- Supplied in plastic stick or tape reel for automated assembling.
- Custom designed circuits also available in 8, 14, 16, 18, and 20pins ceramic packages. Customer service will be advised.
- Industrial electronics, industrial instruments, measurement, automatic test, high-speed digital data transmission, intelligent hubs and routers and data switching.

Dimensions (mm)

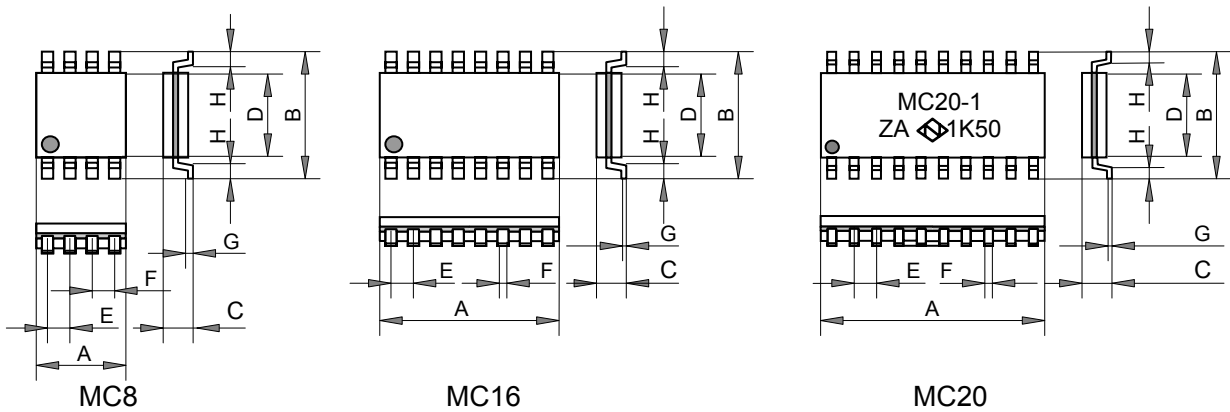

(mm)	A	B	C	D	E	F	G	H
MC8	5.5+/-0.2	8.0+/-0.2	2.3 max	5.3+/-0.2	1.27+/-0.2	0.4+/-0.05	0.2+/-0.1	0.3 min
MC16	10.5+/-0.2	8.0+/-0.2	2.3 max	5.3+/-0.2	1.27+/-0.2	0.4+/-0.05	0.2+/-0.1	0.3 min
MC20	13.0+/-0.5	8.0+/-0.2	2.3 max	5.3+/-0.2	1.27+/-0.2	0.4+/-0.05	0.2+/-0.1	0.3 min

Ordering Information

Type	Schematic	TCR	Resistance	Tolerance	Packaging	Note
MC8	-1	Z	102	A	000	Bulk
MC8	-1	Z (5ppm)	101--223	A (0.05%)	000	Bulk
MC16				B (0.10%)	001	Tape
MC20					003	Tube

SOP RESISTOR NETWORKS

MC8, MC16, MC20

Schematics and Pin Configurations

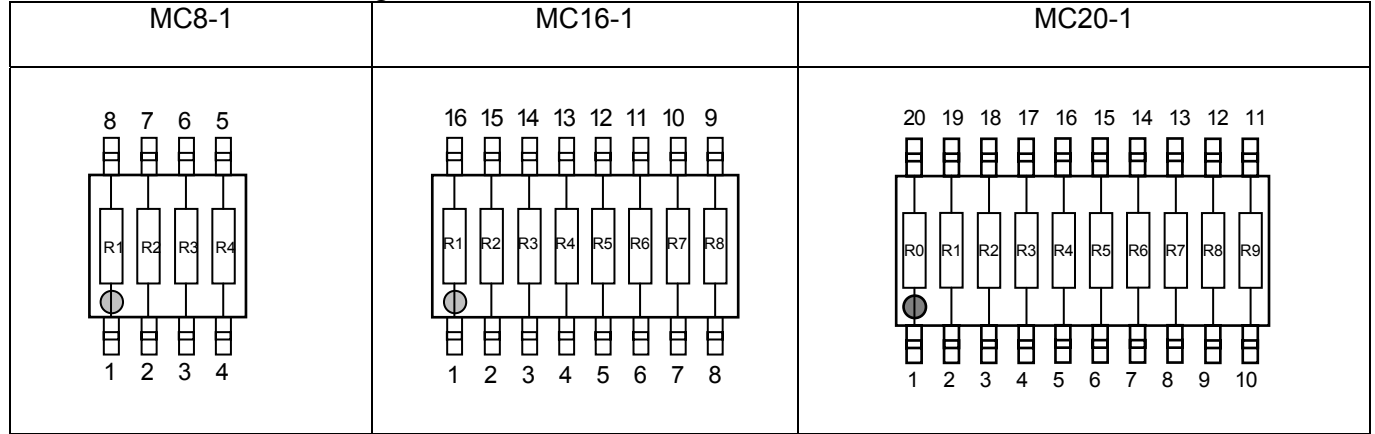

Note: R1=R2=R3=R4=.....is standard schematic, when request for custom resistance value please contact to factory.

Performances

Type	MC8-1	MC16-1	MC20-1
Resistance Range	100-22K ohm	100-22K ohm	100-22K ohm
TC Tracking	(2ppm/K)	(2ppm/K)	(2ppm/K)
Ratio	(0.02%)	(0.02%)	(0.02%)
TC-Absolute	+/-5ppm/K(Z)	+/-5ppm/K(Z)	+/-5ppm/K(Z)
Tolerance-Absolute	+/-0.05% (A), +/-0.1% (B)	+/-0.05% (A), +/-0.1% (B)	+/-0.05% (A), +/-0.1% (B)
Rating Power/Resistor	50mW	50mW	50mW
Rating Power/Package	0.2W	0.4W	0.5W
Max. Operating Volt.	$\sqrt{P \cdot R}$ or 100V		
Rating Temp.	+75 deg C		
Operating Temp. Range	-20 deg C to +120 deg C		
Storage Temp. Range	-55 deg C to +120 deg C		

If Tracking and Ratio specifications are necessary please contact to factory, info@nikkohm.co.jp.

Electrical Specifications

項目	Items	Specifications	Conditions
短時間過負荷	Short Time Overload	+/- (0.05%) absolute	2.5 times rating power, 5 seconds
絶縁抵抗	Insulation Resistance	>10,000Mohm	
絶縁耐電圧	Withstand Voltage	+/- (0.05%) absolute	100V, 60 seconds
熱衝撃	Heat Shock	+/- (0.1%) absolute	5 cycles for temp. -65, +25, +125, +25 C
はんだ耐熱性	Soldering Heat	+/- (0.05%) absolute	350 deg C, 3 seconds
はんだ付性	Solder ability	Covered 95% area	230 deg C, 3 seconds
耐溶剤性	Solvent	No mechanical damage	
耐湿性	Humidity	+/- (0.1%) absolute	40 deg C, 90-95RH, 90min.ON, 30min.OFF, 1000hours
負荷寿命	Load Life	+/- (0.1%) absolute	70 deg C, 90min.ON, 30min.OFF, 1000hours

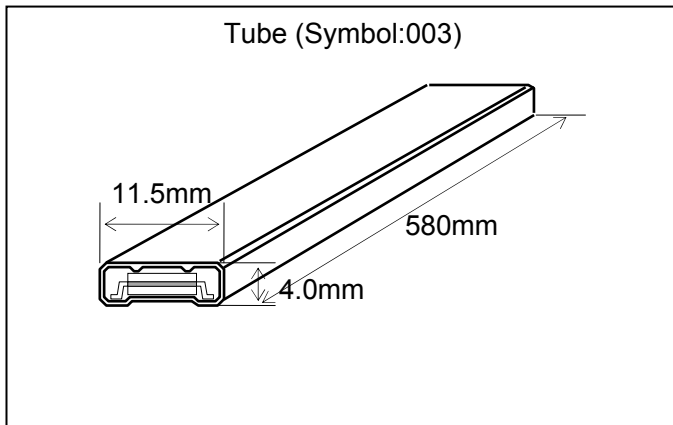

Note:

In P/N definition, additional 3 digits code shows lead-free structure and packaging method. When first digit is "0" then terminals are solder plated, when "Z" tin plated. Third digit "0" shows bulk and "3" shows stick packaging. If you have any question, please call info@nikkohm.com.

RoHS compliance cannot be available, when RoHS is necessary please contact to factory info@nikkohm.com

SOIC, MCN8, MCN16, MCN20 were discontinued at December 2012, please refer MCM as replacement.

SURFACE-MOUNT LADDER NETWORKS

MCL6, MCL8, MCL10

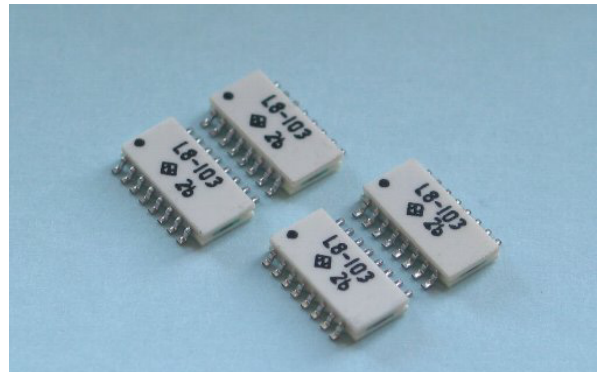

Features and Applications

- 10bit, 8bit and 6bit R-2R ladder resistor networks for voltage output DA conversion circuits.
- Precision thin-film technology assures accuracy of $\pm 1/2\text{LSB}$ at -40 deg C to $+125\text{ deg C}$ and long life stability.
- Standard 16 and 20pins ceramic SOP packages and PE plastic stick.
- Realizes long life stability and wide operating temperatures.
- Industrial power supplies, standard voltage supplies, precision AD converter, digital signal processing, direct digital waveform synthesizer, measurements, industrial instruments, high speed digital data transmission, intelligent hubs and data switching.

Dimensional Specifications (mm)

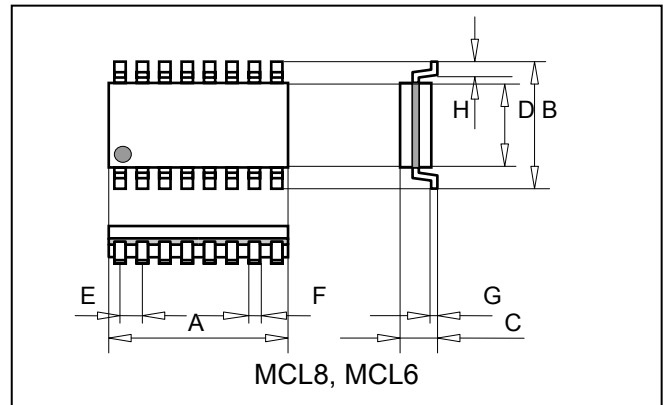
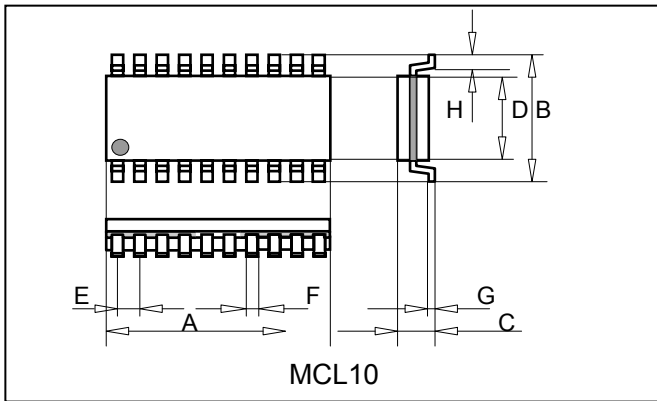

Type	Unit	A	B	C	D	E	F	G	H
MCL10	mm	13.8 \pm 0.2	5.3 \pm 0.2	2.3max	8.0 \pm 0.2	1.27 \pm 0.2	0.4 \pm 0.05	0.2 \pm 0.2	0.3min
MCL8, MCL6	mm	11.3 \pm 0.2	5.3 \pm 0.2	2.3max	8.0 \pm 0.2	1.27 \pm 0.2	0.4 \pm 0.05	0.2 \pm 0.2	0.3min

形名称 Ordering Information

P/N	Type	R1	R2	Packaging
MCL10-102-003	MCL10-	1kohm	2kohm	Stick
MCL10-103-001	MCL10-	10kohm	20kohm	Tape
MCL8-103-003	MCL8-	10kohm	20kohm	Stick
MCL6-102-000	MCL6-	1kohm	2kohm	Bulk

SURFACE-MOUNT LADDER NETWORKS
MCL6, MCL8, MCL10

Schematics

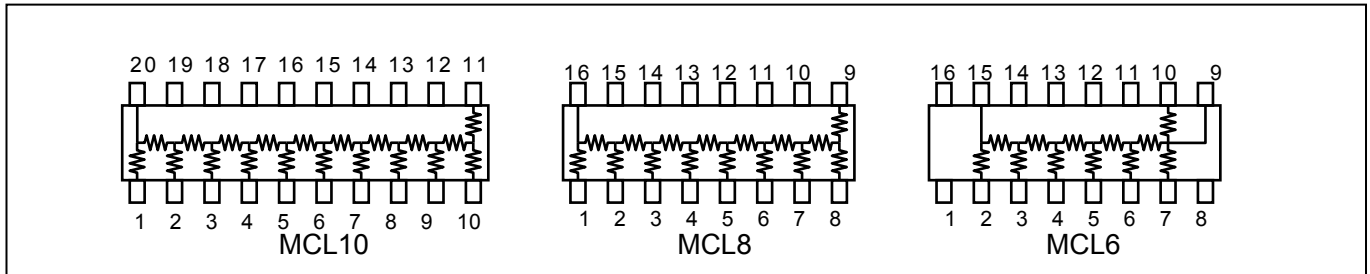

Specifications and Performances

Items	Specifications			Conditions
Type	MCL10	MCL8	MCL6	
Conversion Type	Volt. Output	Volt. Output	Volt. Output	
Resolution	10bits	8bits	6bits	
Resistance Range (ohm)	1k-2k or 10k-20k			R-2R
Linearity	+/-1/2LSB	+/-1/2LSB	+/-1/2LSB	-55 deg C – 155 deg C
Rating Voltage, Max.	10V	10V	10V	
TC-Absolute	+/-5ppm/C	+/-5ppm/C	+/-5ppm/C	
Tolerance-Absolute	+/-0.1%	+/-0.1%	+/-0.1%	
Rating Power	0.1 Watts/resistor			0C – 70 deg C
Applied Volt.	100V or sqrt(PR)			
Humidity	+/-0.25%			
Load Life	+/-0.25%			
Temp. Cycle	+/-0.25%			
Soldering Heat	+/-0.10%			350C+/-5C, 3 seconds
Operating Temp. Range	-55 - +120 deg C			
Storage Temp. Range	-55 - +120 deg C			

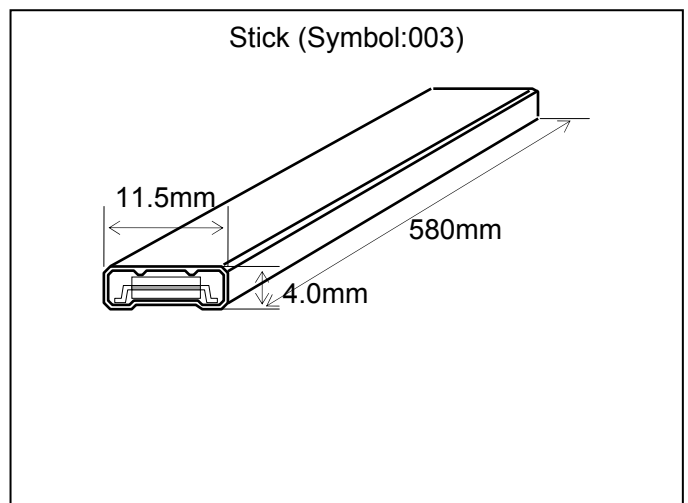
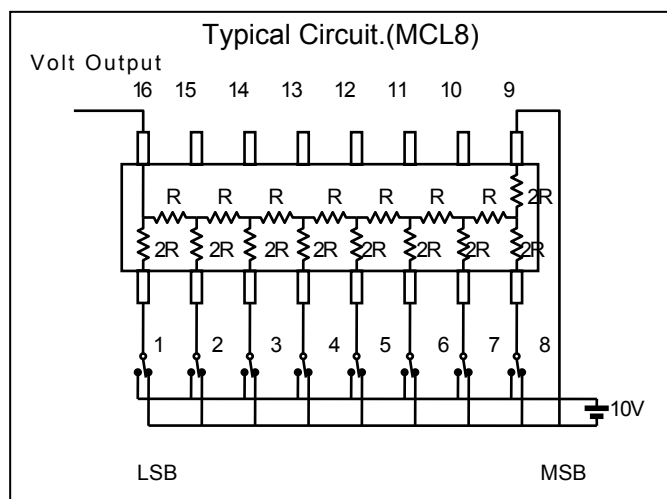

THROUGH-HOLE MATCHED PAIR
SIP RESISTOR NETWORKS
2S, 2M, 2T

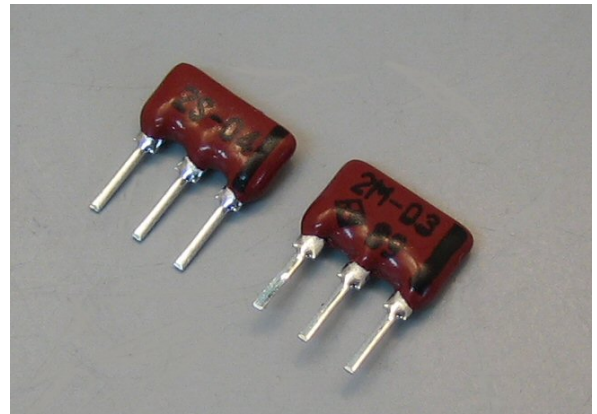

Features and Applications

High precision matched pair SIP resistor networks made by Ni-Cr thin film sputter on alumina substrates with high density patterning technologies.
 1ppm-0.05% tight ratio tolerance and TC tracking are realized at 2T series.
 2S and 2M show good performance and economical.
 A lot of combination of resistance value is standardized for quick delivery.
 2.5mm width slim body and 5.0mm high from PC board fit for high density layout design. (2S)
 Wide applications such as voltage dividers, feed back resistors, voltage reference circuit in data processing, data transmission, precision power sources of industrial controls, medical, measurements, ATE.

Dimensions (mm)

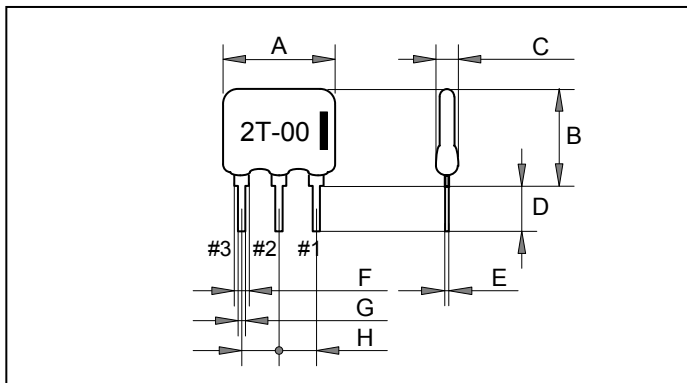

	2T	2S	2M
A	8.0max	8.0max	8.0max
B	5.0max	5.0max	7.0max
C	2.54max	2.54max	2.54max
D	3.3	3.3	3.3
E	0.25	0.25	0.25
F	1.2	1.2	1.2
G	0.5	0.5	0.5
H	2.54	2.54	2.54

Ordering Information

p/n
2T-01
2T-01, 2T-02, 2T-03, 2T-04, 2T-05, 2T-06, 2T-07, 2T-08, 2T-09, 2T-10, 2T-11, 2T-12, 2T-13, 2T-14, 2T-15, 2T-16, 2T-17, 2T-18
2S-01, 2S-02, 2S-03, 2S-04, 2S-05, 2S-06, 2S-07, 2S-08, 2S-09, 2S-10, 2S-11, 2S-12, 2S-13, 2S-14, 2S-15, 2S-16, 2S-17, 2S-18
2M-01, 2M-02, 2M-03, 2M-04, 2M-05, 2M-06, 2M-07, 2M-08, 2M-09, 2M-10, 2M-11, 2M-12, 2M-13, 2M-14, 2M-15, 2M-16, 2M-17, 2M-18

Code
Z00
Z00

Note
Bulk

THROUGH-HOLE MATCHED PAIR SIP RESISTOR NETWORKS 2T, 2S, 2M

Electrical specifications

Type	Resistance		Tolerance		TCR		Pin configurations
	R1,#2-#3	R2,#1-#2	Absolute	Ratio	Absolute	Tracking	
2M-01 2S-01	1Kohm	1Kohm	+/-1%	0.1%	+/-25ppm	5ppm	
2M-02 2S-02	1Kohm	10Kohm	+/-1%	0.1%	+/-25ppm	5ppm	
2M-03 2S-03	10Kohm	10Kohm	+/-1%	0.1%	+/-25ppm	5ppm	
2M-04 2S-04	10Kohm	20Kohm	+/-1%	0.1%	+/-25ppm	5ppm	
2M-05 2S-05	20Kohm	20Kohm	+/-1%	0.1%	+/-25ppm	5ppm	
2M-06 2S-06	15Kohm	15Kohm	+/-1%	0.1%	+/-25ppm	5ppm	
2M-07 2S-07	30Kohm	30Kohm	+/-1%	0.1%	+/-25ppm	5ppm	
2M-08 2S-08	3Kohm	680ohm	+/-1%	0.1%	+/-25ppm	5ppm	
2M-09 2S-09	2.2Kohm	10Kohm	+/-1%	0.1%	+/-25ppm	5ppm	
2M-10 2S-10	50Kohm	50Kohm	+/-1%	0.1%	+/-25ppm	5ppm	
2M-11 2S-11	30Kohm	10Kohm	+/-1%	0.1%	+/-25ppm	5ppm	
2M-12 2S-12	60Kohm	20Kohm	+/-1%	0.1%	+/-25ppm	5ppm	
2M-13 2S-13	18Kohm	2Kohm	+/-1%	0.1%	+/-25ppm	5ppm	
2M-14 2S-14	1Kohm	3Kohm	+/-1%	0.1%	+/-25ppm	5ppm	
2M-15 2S-15	1Kohm	9Kohm	+/-1%	0.1%	+/-25ppm	5ppm	
2M-17 2S-17	3Kohm	6Kohm	+/-1%	0.1%	+/-25ppm	5ppm	
2M-18 2S-18	2Kohm	10Kohm	+/-1%	0.1%	+/-25ppm	5ppm	

Type	Resistance		Tolerance		TCR		Pin configurations
	R1,#2-#3	R2,#1-#2	Absolute	Ratio	Absolute	Tracking	
2T-01	1Kohm	1Kohm	+/-0.1%	0.05%	+/-5ppm	1ppm	
2T-02	1Kohm	10Kohm	+/-0.1%	0.05%	+/-5ppm	1ppm	
2T-03	10Kohm	10Kohm	+/-0.1%	0.05%	+/-5ppm	1ppm	
2T-04	10Kohm	20Kohm	+/-0.1%	0.05%	+/-5ppm	1ppm	
2T-05	20Kohm	20Kohm	+/-0.1%	0.05%	+/-5ppm	1ppm	
2T-06	15Kohm	15Kohm	+/-0.1%	0.05%	+/-5ppm	1ppm	
2T-07	30Kohm	30Kohm	+/-0.1%	0.05%	+/-5ppm	1ppm	
2T-08	3Kohm	680ohm	+/-0.1%	0.05%	+/-5ppm	1ppm	
2T-09	2.2Kohm	10Kohm	+/-0.1%	0.05%	+/-5ppm	1ppm	
2T-10	50Kohm	50Kohm	+/-0.1%	0.05%	+/-5ppm	1ppm	
2T-11	30Kohm	10Kohm	+/-0.1%	0.05%	+/-5ppm	1ppm	
2T-12	60Kohm	20Kohm	+/-0.1%	0.05%	+/-5ppm	1ppm	
2T-13	18Kohm	2Kohm	+/-0.1%	0.05%	+/-5ppm	1ppm	
2T-14	1Kohm	3Kohm	+/-0.1%	0.05%	+/-5ppm	1ppm	
2T-15	1Kohm	9Kohm	+/-0.1%	0.05%	+/-5ppm	1ppm	
2T-17	3Kohm	6Kohm	+/-0.1%	0.05%	+/-5ppm	1ppm	
2T-18	2Kohm	10Kohm	+/-0.1%	0.05%	+/-5ppm	1ppm	

Specifications and Performances

Type	2T	2S	2M	Test Conditions
Rating Power/element	125mW	125mW	125mW	250mW/Package
Rated Ambient Temp.	70 deg C	70 deg C	70 deg C	
Operating Temp. Range	-55 to +125 degC			
Tax. Applied Voltage	Less than 100V			Accordance with $E = \sqrt{P \cdot R}$
Short Time Overload	+/-0.1 % Abs			2.5 times rated power, 5seconds
Load Life	+/-0.1 % Abs			70C, 90min ON, 30min OFF, 1000hours
Humidity	+/-0.25 % Abs			40C, 90-95RH, DC 0.1W, 1,000hours
Soldering Heat	+/-0.1 % Abs			350C, 3seconds
Withstanding Voltage	+/-0.1 % Abs			1000VAC, 60seconds
Insulation Resistance	10,000Mohm			

THROUGH-HOLE SIP RESISTOR NETWORKS

MP

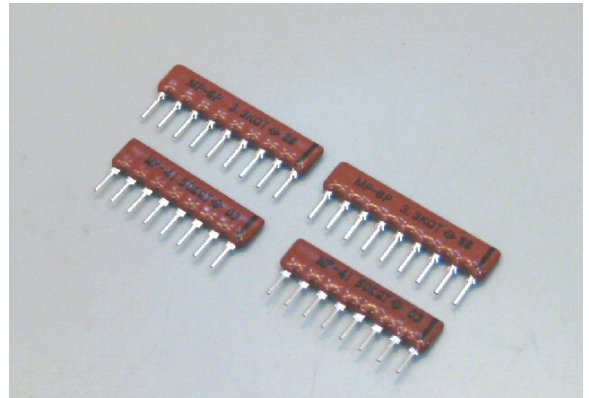

Features and Applications

High precision through-hole SIP resistor networks made by NiCr thin film sputter on alumina substrates with high density patterning technologies.
 5ppm-0.05% tight ratio tolerance and TC tracking are realized.
 Individual (type I), series (type S) and parallel (P) circuit schematics are available.
 2.5 mm width slim body and 7.5 mm height from PC board fit for high-density layout design.
 Wide applications such as voltage dividers, feed back resistors for op amp, gain control circuit, termination of data transmission and voltage reference circuit, in data processing, data transmission, precision power sources of industrial controls, measurements, medical, measurements and automatic test systems.

Dimensions (mm) and Marking

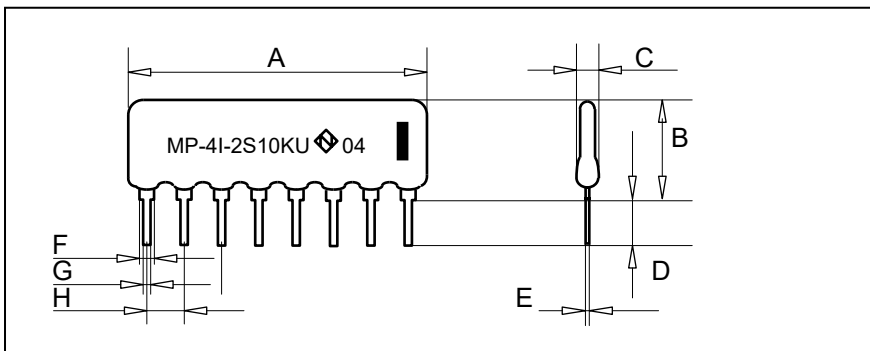

■ : No.1 pin identification
 MP-4I-2: Type
 S: TCR and tracking
 10K: Resistance
 U: Tolerance and ratio
 ◇: Manufacturer's ID
 34: Date code
 Note: When A is too small to print full characters, marking will be omitted style.

(mm)	4 pins	5 pins	6 pins	7 pins	8 pins	9 pins	10 pins
A	10.2+/-1.5	12.7+/-1.5	15.2+/-1.5	17.8+/-1.5	20.3+/-1.5	22.9+/-1.5	25.4+/-1.5
B	7.0 mm max.						
C	3.0 mm max.						
D	3.3 mm						
E	0.25 mm						
F	1.2 mm						
G	0.5 mm						
H	2.54 mm						

THROUGH-HOLE SIP RESISTOR NETWORKS

MP

Ordering Information

Model	TCR (abs-track)	Resistance	Tolerance (abs-ratio)	RoHS
MP-2I-2	A (100ppm-abs)	47R0-22K0	J (5.0%-abs)	Z00
MP-3I-2	C (50ppm-abs)		F (1.0%-abs)	
MP-4I-2	Z (5ppm-abs)		B (0.1%-abs)	
	R(5ppm-1ppm)		S(0.1%-0.05%)	
MP-3S-2	Q(10ppm-5ppm)		T(0.1%-0.1%)	
MP-4S-2	S(25ppm-5ppm)		U(0.5%-0.1%)	
MP-6S-2	L(50ppm-5ppm)		V(1.0%-0.1%)	
	P(50ppm-10ppm)		Y(1.0%-0.5%)	
MP-4P-2				
MP-6P-2				
MP-8P-2				

Resistance, TCR, Tolerance, Tracking and Ratio

Resistance	TCR Symbol	TCR		Tolerance Symbol	Tolerance	
		Absolute	Tracking		Absolute	Ratio
47 ohm – 22Kohm	R	+/- 5ppm	1ppm	S	+/-0.1%	+/-0.05%
	Q	+/-10ppm	5ppm	T	+/-0.1%	0.1%
	S	+/-25ppm	5ppm	U	+/-0.5%	0.1%
	L	+/-50ppm	5ppm	V	+/-1.0%	0.1%
	P	+/-50ppm	10ppm	Y	+/-1.0%	0.5%

Note1: Table shows a case of tracking and ratio, specify only absolute available.

Schematics

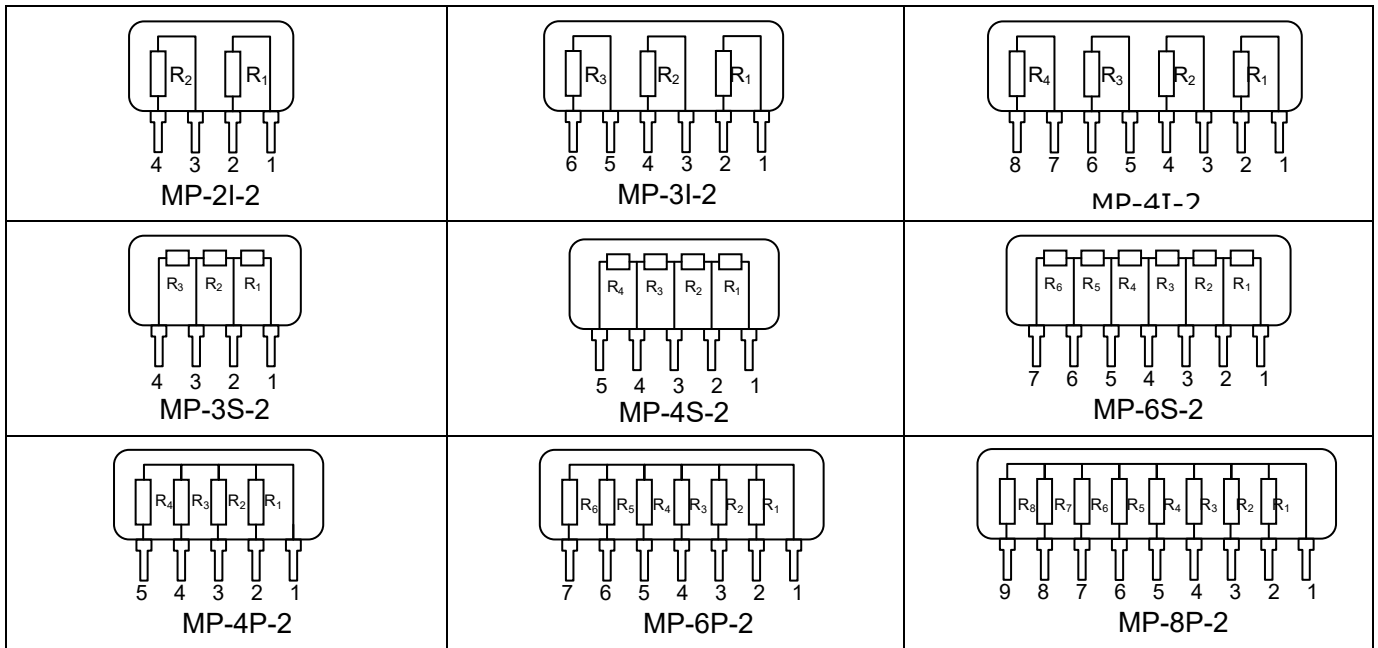

Specifications and Performance

	Specifications	Conditions
Rating Power	125mW	
Rated Ambient Temp.	70 deg C	
Operating temp. Range	-55 to +125 deg C	
Max. Applied Voltage	100V or Accordance with E=sqrt(PR)	
Short Time Overload	+/-0.1 % Abs	2.5 times rated power, 5seconds
Load Life	+/-0.1 % Abs	70C, 90min ON, 30min OFF, 1000hours
Humidity	+/-0.25 % Abs	60C, 90-95RH, DC 0.1W, 1,000hours
Soldering Heat	+/-0.1 % Abs	350C, 3seconds
Withstanding Voltage	+/-0.1 % Abs	1000VAC, 60seconds
Insulation Resistance	10,000Mohm	

20170201

RF POWER RESISTORS

RFR010-010, RFR050-010,
RFR100-010, RFR250-010

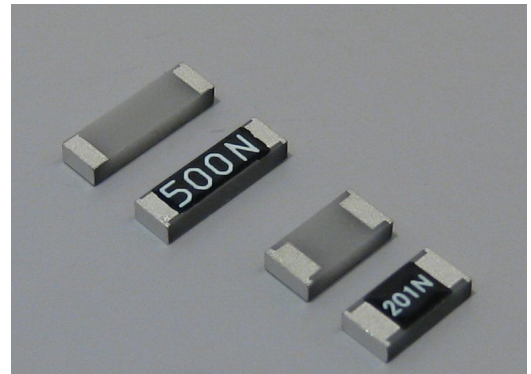

Features and Applications

RFR000-010, RFH and RFK are specified rating power of 10W to 250W, resistance of 50ohm to 800ohm for microwave applications. Heat from the resistors can be extracted through back metal or flange to PCB or case heat sink. RF application.

Small sized large power handling feature shows excellent RF characteristics in equipment with RoHS compliance and Beryllium free design.

1% tolerance and 50ppm/degree tight resistances are made application circuit stable.

RF power amplifiers, RF power source, fixed station of cell phone, RF measurement and terminations of circulators / isolators.

Ordering Information

Type	Style	TCR	Resistance	Tolerance	RoHS/Package
RFR050	010	C	201	F	Z01
RFH52	010	C	500	F	Z01
RFH72	020	(50ppm)	101	(1.0%)	
RFT010			151		
RFT050			201		
RFT080			251		
RFT100			301		
RFT150			401		
RFT200			601		
RFT250			801		

Specifications and Performances

Type	RFH52	RFH72	RFR010-0	RFR050-0	RFR100-0	RFR250-0
Rating Power with Heatsink	10W	10W	10W	50W	100W	250W
Packaging (pcs/tape & reel)	2000	2000	2000	2000	1000	1000
Resistance	50, 100, 150, 200, 250, 300, 400, 600, 800 ohm					
TC	+/-50ppm/K (C)					
Tolerance	+/-1.0% (F)					
Rated Ambient Temp.	100 deg C					
Operating Temp Range	-55 deg C-155 deg C					
Load Life	+/-0.5%					
Humidity	+/-0.5%					
Series Inductance	-					
Parallel Capacitance	-					

Materials

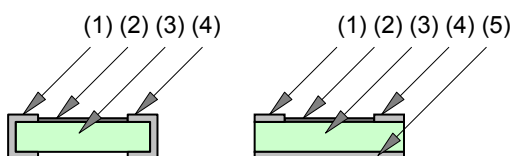

	Substance	Material
(1)	Cold End Terminal	Tin plated Ni-Cu
(2)	Resistive	Ni-Cr
(3)	Substrate	ALN
(4)	Hot End Terminal	Tin plated Ni-Cu
(5)	Back Metal	Tin plated Ni-Cu

RF POWER RESISTOR

RFH, RFK, RFR010-0, RFR050-0, RFR100-0, RFR250-0

Dimension

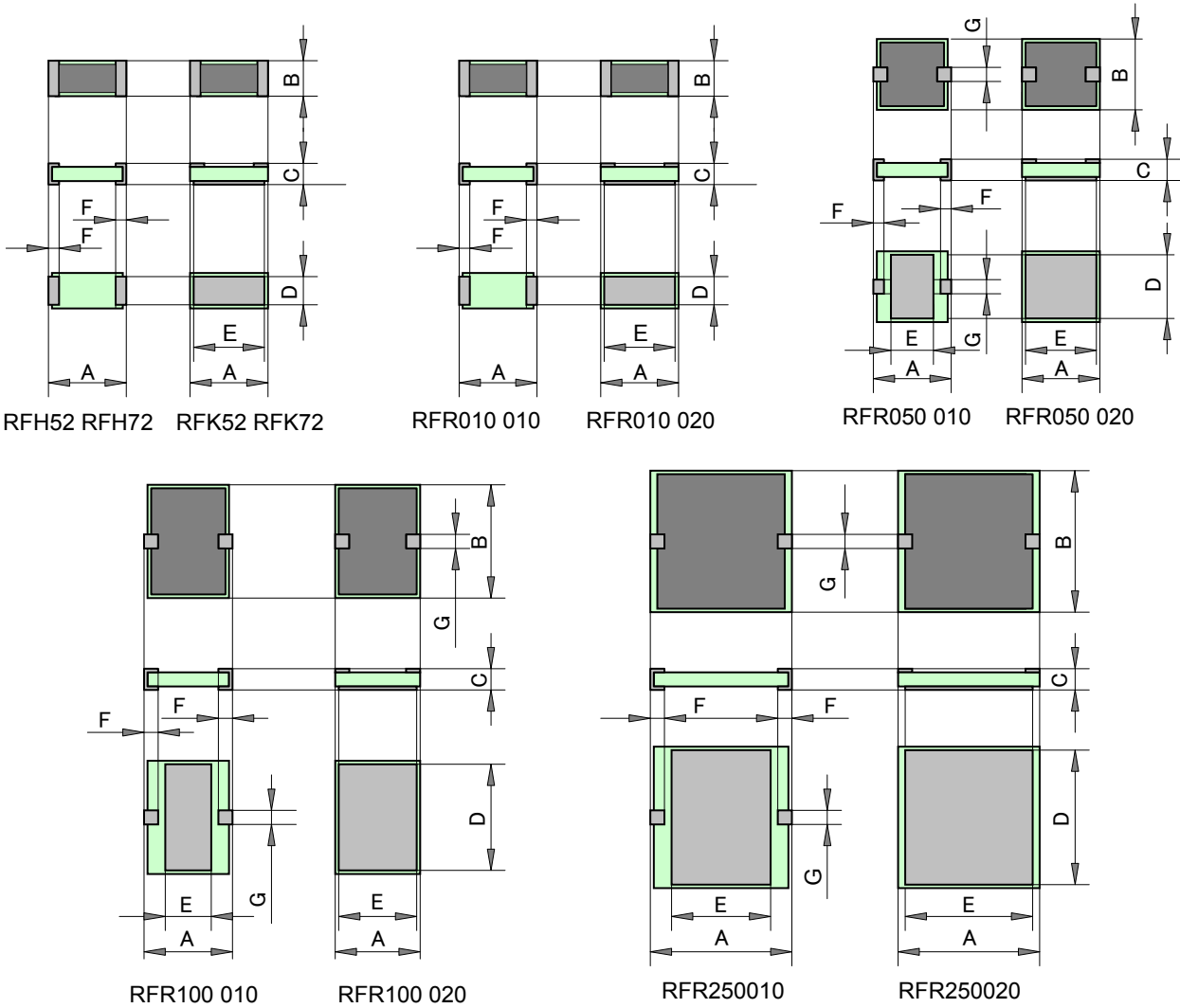

Type	Power	A	B	C	D	E	F	G
RFH52	10W	5.0	2.5	1.2max	-	-	0.8	-
RFH72	10W	7.0	2.0	1.2max	-	-	0.8	-
RFK52	10W	5.0	2.5	1.2max	2.3	4.8	0.8	-
RFK72	10W	7.0	2.0	1.2max	1.8	6.8	0.8	-

Type	Power	A	B	C	D	E	F	G
RFR010 010	10W	5.08	2.54	1.05	-	-	1.27	-
RFR010 020		5.08	2.54	1.05	2.34	4.88	1.27	-
RFR050 010	50W	5.08	5.08	1.05	4.84	2.00	1.27	1.27
RFR050 020		5.08	5.08	1.05	4.84	4.68	1.27	1.27
RFR100 010	100W	5.84	8.89	1.05	8.49	2.54	1.27	1.27
RFR100 020		5.84	8.89	1.05	8.49	5.45	1.27	1.27
RFR250 010	250W	9.52	9.52	1.05	9.12	6.00	1.27	1.27
RFR250 020		9.52	9.52	1.05	9.12	9.12	1.27	1.27

Note1: Gap of "J" shall be sufficient height as RF characteristics.

RF POWER RESISTOR

RFH, RFK, RFR010-0, RFR050-0, RFR100-0, RFR250-0

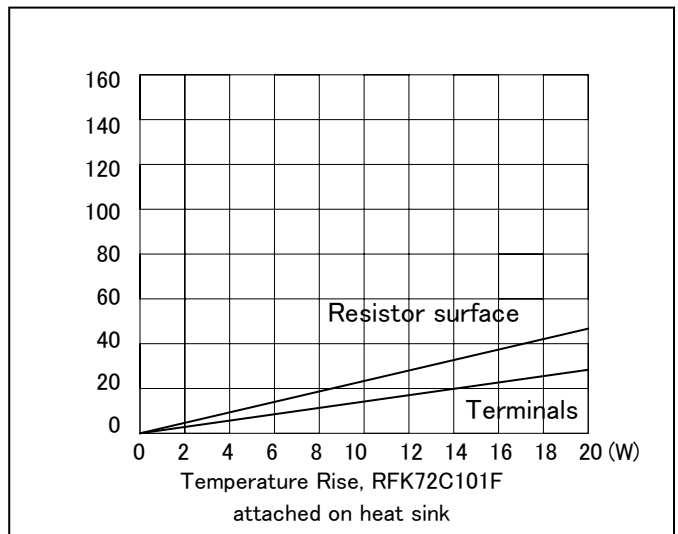
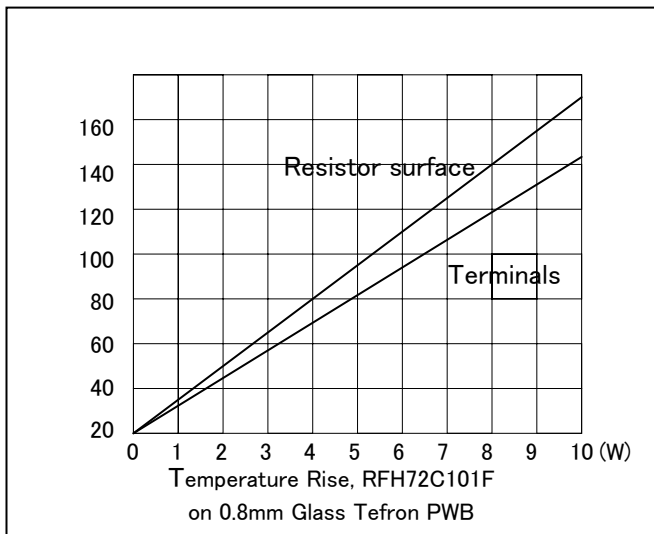
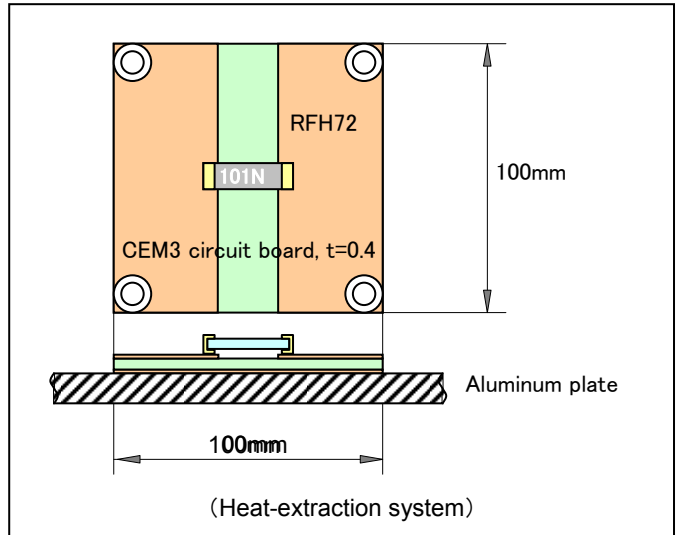
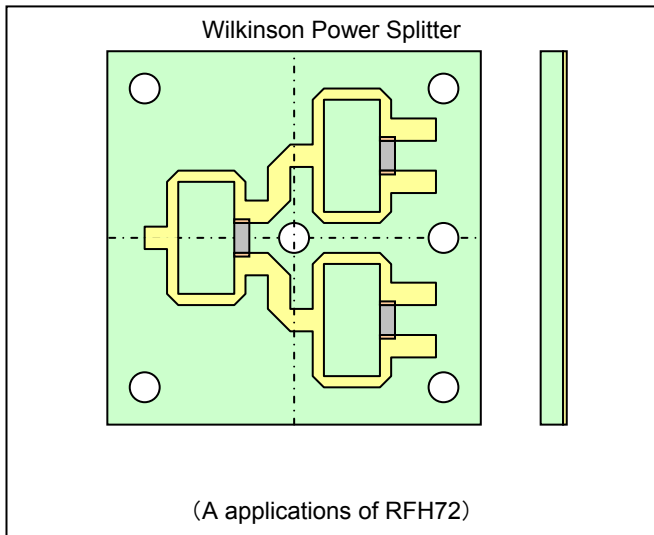
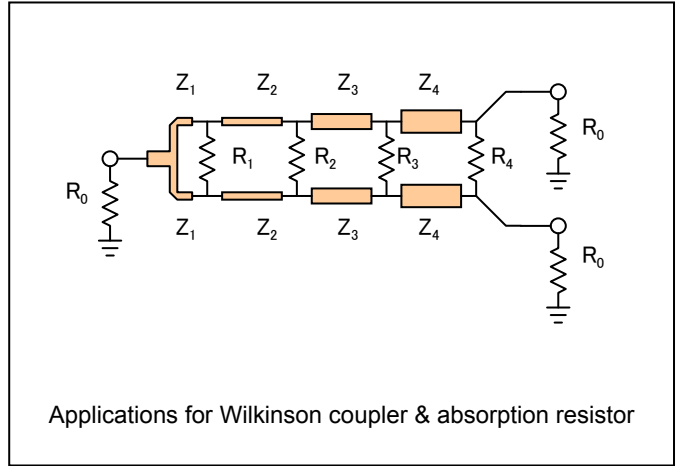
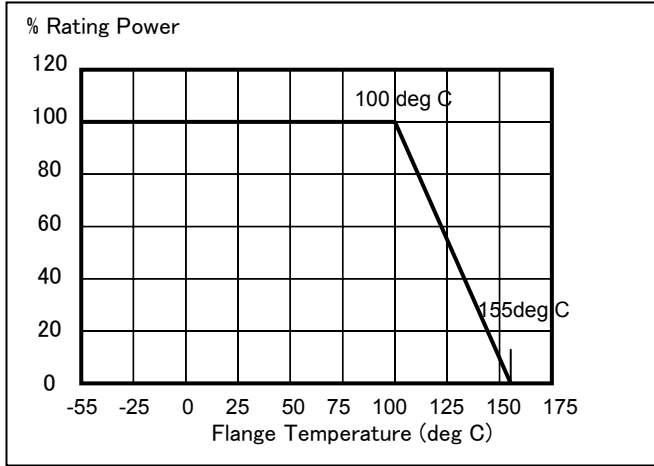

RF POWER RESISTOR

RFH, RFJ, RFK, RFR010-0, RFR050-0, RFR100-0, RFR250-0

Foot Pattern

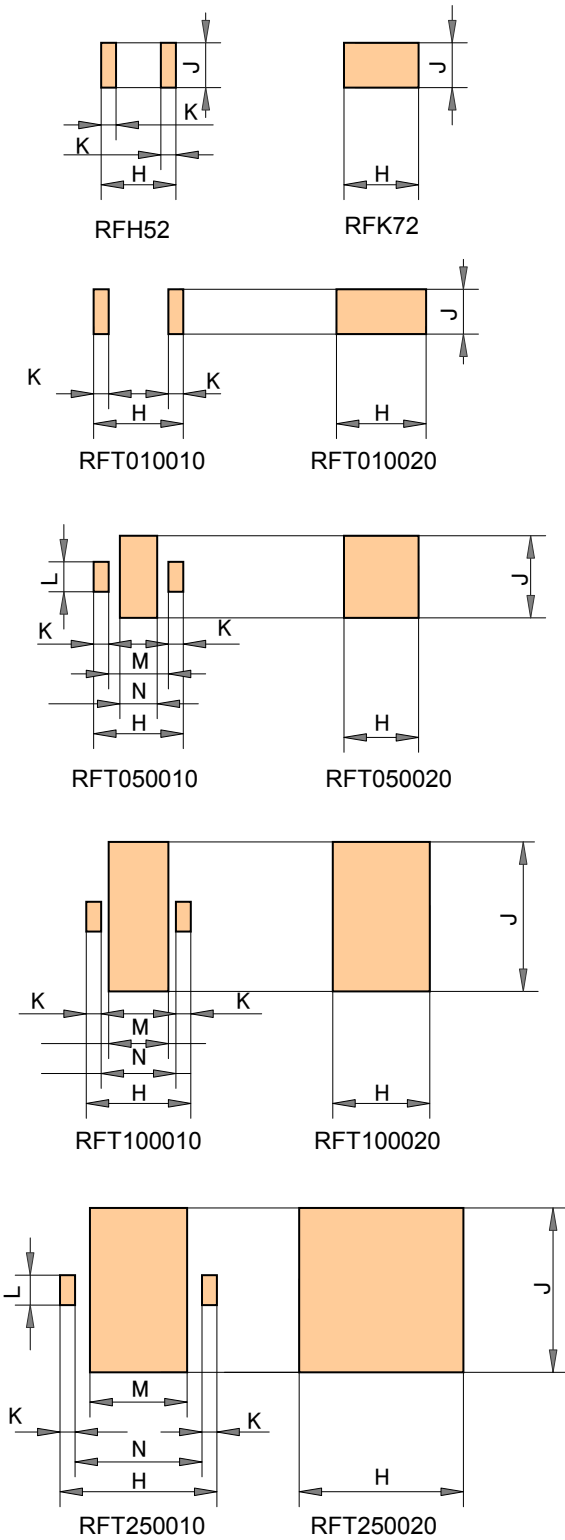

(mm)	H	J	K	L	M	N
RFH52	5.40	2.70	1.20	-	-	-
RFH72	7.40	2.40	1.20	-	-	-
RFK52	5.40	2.70	-	-	-	-
RFK72	7.40	2.40	-	-	-	-
RFT010 010	5.48	2.94	1.67	-	-	-
RFT010 020	5.48	2.94	-	-	-	-
RFT050 010	5.48	5.48	1.47	1.47	2.54	2.14
RFT050 020	5.48	5.48	-	-	-	-
RFT100 010	6.24	9.29	1.47	1.47	3.30	2.90
RFT100 020	6.24	9.29	-	-	-	-
RFT250 010	9.92	9.92	1.47	1.47	6.98	6.58
RFT250 020	9.92	9.92	-	-	-	-

Frequency Characteristic

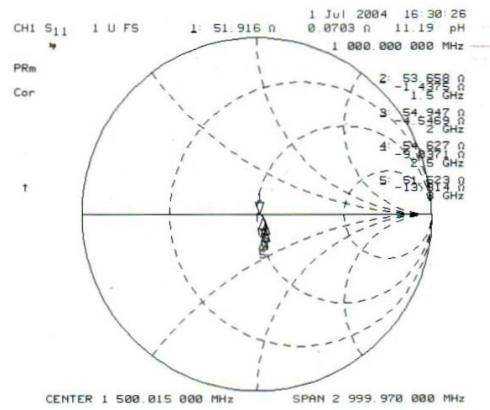

S11, RFH72C500F

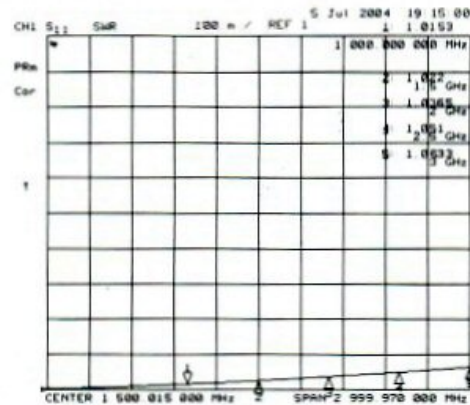

VSWR, RFH72C500F

10W, 50W, 80W, 100W, 150W, 200W, 250W
FLANGED POWER RESISTORS, RFR

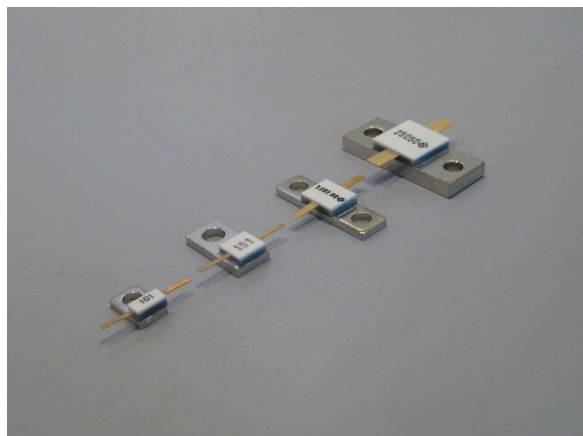

Features:

- High power flanged resistors for all DC up to 4GHz applications.
- Small size and wide frequency range specifications realized with through large heat conducting AlN substrate.
- Sufficient mechanical strength metallization from spattered thin film technology.
- 50ohm resistance with tolerance 1%, and terminations include chips and many style flange provided as standard, and other resistance and power available.
- Long life and temperature stability are shown by a result of Ni-Cr thin film technology.
- Applications include power absorption resistor, termination for isolator/circulators, base station of mobile communication electronics, High power microwave amplifiers.

Ordering Information

Type	Style	TCR	Resistance	Tolerance	RoHS/Package
RFR050	120	C	201	F	Z00
RFR010	110	C	50 Ohm	F	Z00
RFR050	120	(50ppm)	100 Ohm	(1.0%)	
RFR080			150 Ohm		
RFR100			200 Ohm		
RFR150			250 Ohm		
RFR200			300 Ohm		
RFR250			400 Ohm		
			600 Ohm		
			800 Ohm		

Performance Specifications

Type	Rated Power (W)	Heat Resistance (deg C/W)	VSWR 500MHz	VSWR 1GHz	VSWR 2GHz
RFR010	10	6.5		1.15	
RFR050	50	2.5		1.15	
RFR080	80			1.20	
RFR100	100	1.3		1.20	
RFR150	150			1.30	
RFR200	200	0.5			
RFR250	250	0.5		1.30	

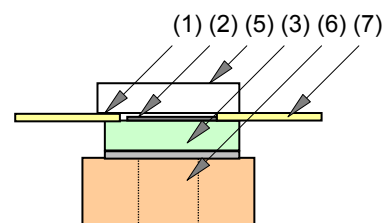

	Substance	Material
(1)	Cold end Terminal	Tin plated Ni-Cu
(2)	Resistive	Ni-Cr
(3)	Substrate	ALN
(4)	Hot end Terminal	Tin plated Ni-Cu
(5)	Cover	ALO
(6)	Flange	Ni plated Cu
(7)	Beam Lead	Au plated Cu

10W, 50W, 80W, 100W, 150W, 200W, 250W RESISTORS

Style and Dimension (mm)

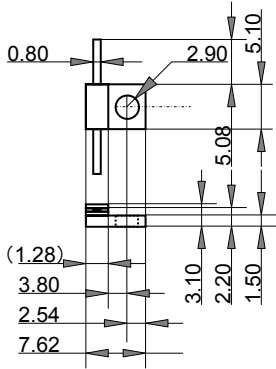

RFR010 120

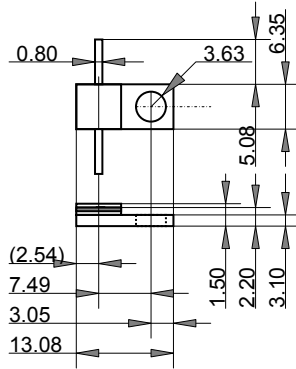

RFR050 120 RFR080 120

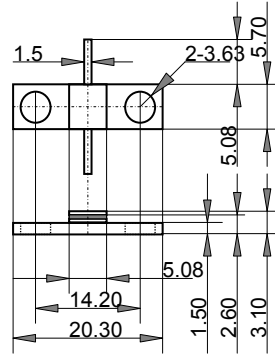

RFR050 110

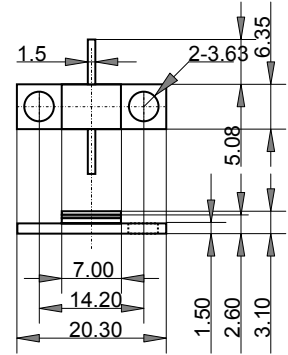

RFR100 110

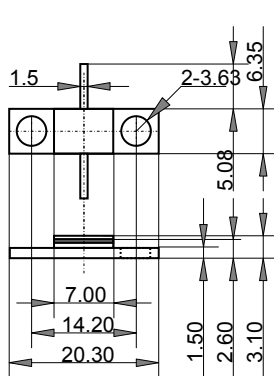

RFR150 110

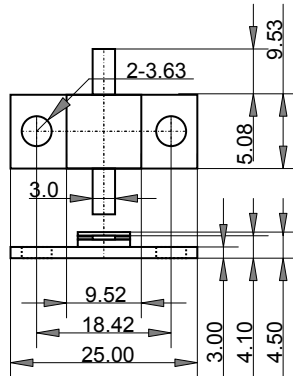

RFR200 110

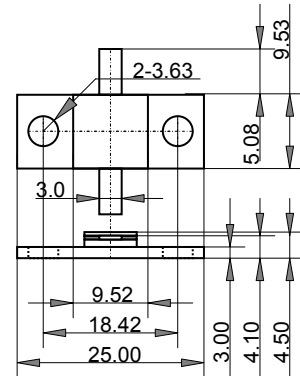

RFR250 110

Derating Curve

% Rating Power

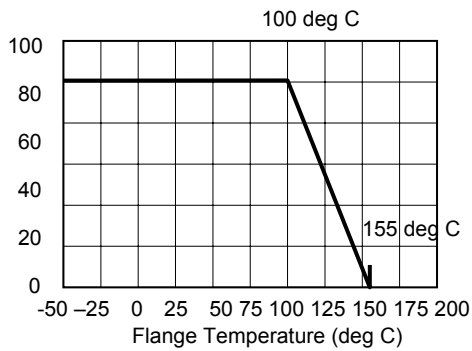

Installation

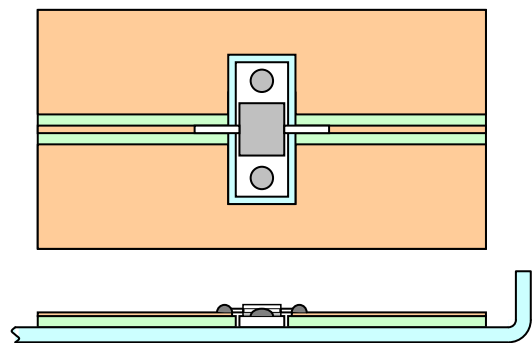

5W, 10W, 50W, 100W, 250W
 HIGH POWER SMD TERMINATIONS
 RFT005, RFT010, RFT050, RFT100,
 RFT150, RFT250

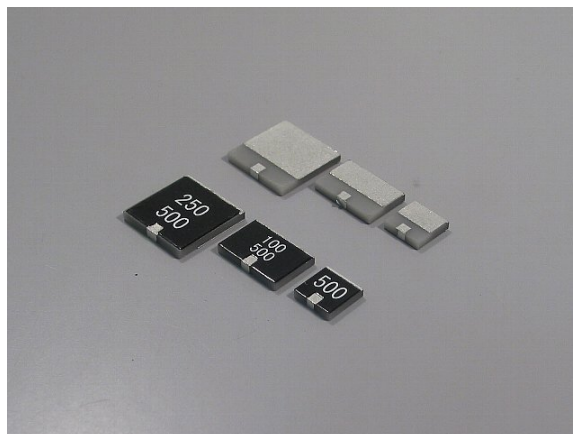

Features and Applications

High power surface mount termination for all DC up to 5GHz applications.

Small size and wide frequency range specifications realized with through large heat conducting AlN substrate.

Sufficient mechanical strength metallization from spattered thin film technology.

50ohm resistance with tolerance 1% and 10W, 50W, 100W, 150W and 250W provided as standard, and other resistance and power available.

Long life and temperature stability a result of Ni-Cr thin film technology.

Termination for isolator/circulators, fixed station of mobile communication electronics, and high power microwave amplifiers.

Ordering Information

Type	Structure	TCR	Resistance	Tolerance	Packaging	Note
RFT100	010	C	500	F	Z01	
RFT010	010	C	500	F	Z00	Bulk
RFT050	020	(50ppm/C)	(50 Ohm)	(1%)	Z01	Tape reel
RFT100						
RFT150						
RFT250						

Specifications and Performances

Type	RFT010	RFT050	RFT100	RFT150	RFT250	Conditions
Rated Power (W)	10	30	100	150	250	-55 - +100 deg C
Maximum Power (W)	20	50	200	300	500	Pulse < 1 second
Resistance (Std) Ohm	50 Ohms					
TC (ppm/deg C)	50					
Tolerance (%)	1.0					
Heat Resistance (deg C/W)	5.5	1.1	0.5	0.3	0.2	
VSWR at 1GHz	1.15	1.15	1.20	1.20	1.20	
Max Operating Temperature	-55-155 deg C					
Storage Temperature	-55-155 deg C					

5W, 10W, 50W, 100W, 250W
HIGH POWER TERMINATIONS RFT050, RFT010, RFT050, RFT100, RFT250

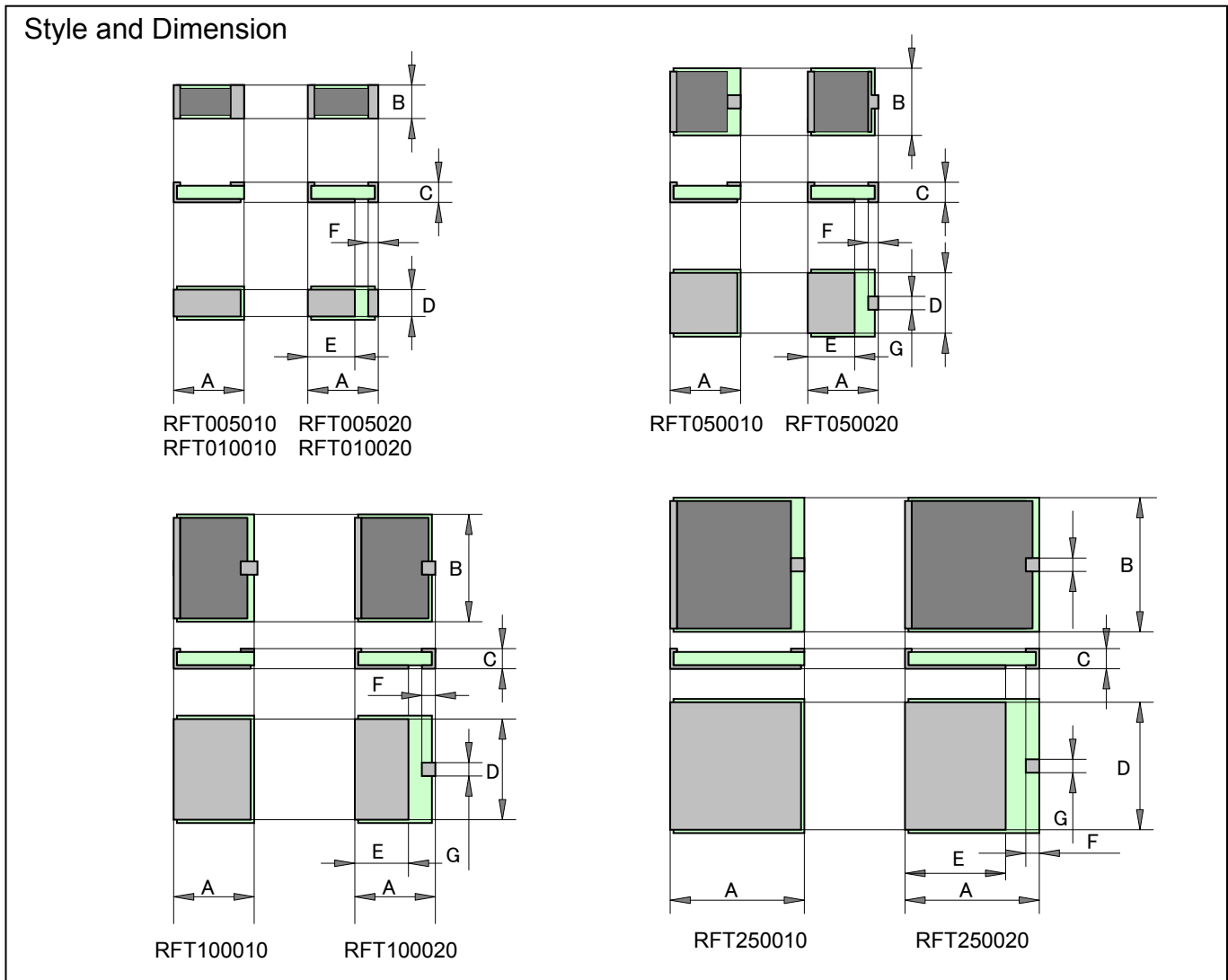

Type	Power	A	B	C	D	E	F	G
RFT010 010	10W	5.08	2.54	1.05	2.34	-	1.27	1.27
RFT010 020		5.08	2.54	1.05	2.30	2.54	1.27	1.27
RFT050 010	50W	5.08	5.08	1.05	4.84	-	1.27	1.27
RFT050 020		5.08	5.08	1.05	4.84	2.54	1.27	1.27
RFT100 010	100W	5.84	8.89	1.05	8.49	-	1.27	1.27
RFT100 020		5.84	8.89	1.05	8.49	3.05	1.27	1.27
RFT150 010	150W	6.35	9.52	1.05	9.12	-	1.27	1.27
RFT150 020		6.35	9.52	1.05	9.12	4.05	1.27	1.27
RFT250 010	250W	9.52	9.52	1.05	9.12	-	1.27	1.27
RFT250 020		9.52	9.52	1.05	9.12	6.98	1.27	1.27

Materials

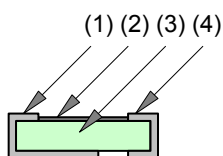

	Substance	Material
(1)	Cold end Terminal	Tin plated Ni + Cu
(2)	Resistive	Ni-Cr
(3)	Substrate	ALN
(4)	Hot end Terminal	Tin plated Ni + Cu

5W, 10W, 50W, 100W, 250W
HIGH POWER TERMINATIONS RFT050, RFT010, RFT050, RFT100, RFT250

Foot Pattern Design

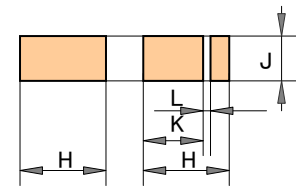

RFT010010 RFT010020

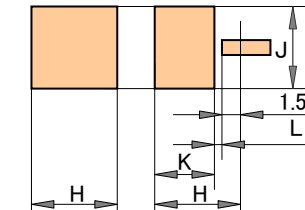

RFT050010 RFT050020

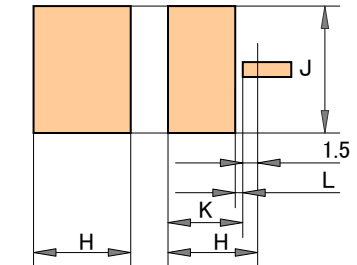

RFT100010 RFT100020

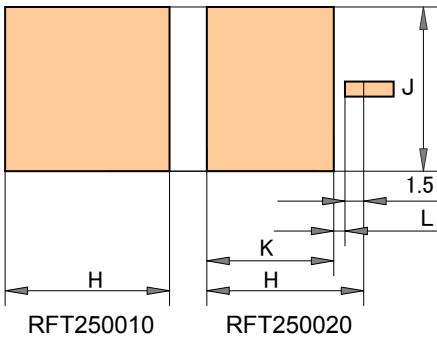

RFT250010 RFT250020

	H	J	K	L
RFT010 010	5.48	2.94	-	-
RFT010 020	5.48	2.94	(2.98)	0.5
RFT050 010	5.48	5.48	-	-
RFT050 020	5.48	5.48	(2.98)	0.5
RFT100 010	6.24	9.29	-	-
RFT100 020	6.24	9.29	(3.24)	0.5
RFT150 010	6.75	9.92	--	---
RFT150 020	6.75	9.92	(4.48)	0.5
RFT250 010	9.92	9.92	--	-
RFT250 020	9.92	9.92	(6.92)	0.5

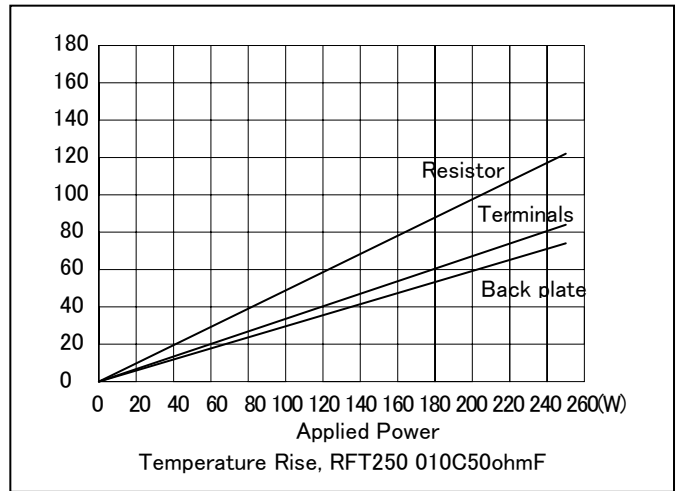
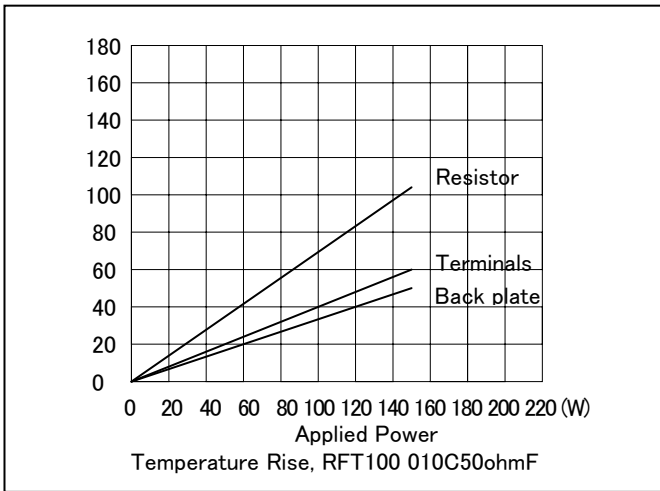

Note:

- (1) Other resistance value and substrate thickness are available. Please consult Nikkohm factory.
- (2) Power rating assumes that chip attached on metal plate.
- (3) Solder joint design should assure a solder thickness within 50 micron meters.

Derating Curve

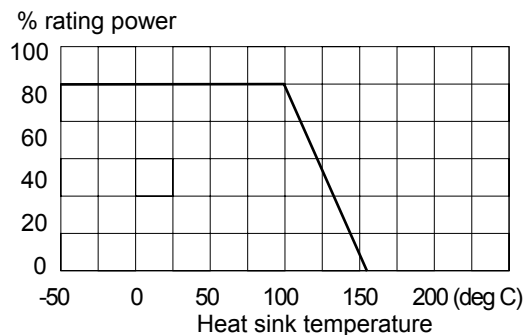

**SURFACE MOUNT
HIGH POWER TERMINATIONS**

RFTS05, RFTS10, RFTS50, RFTS100
RFTSA100, RFTSA150, RFTSA250
RFTSB100, RFTSB150, RFTSB250

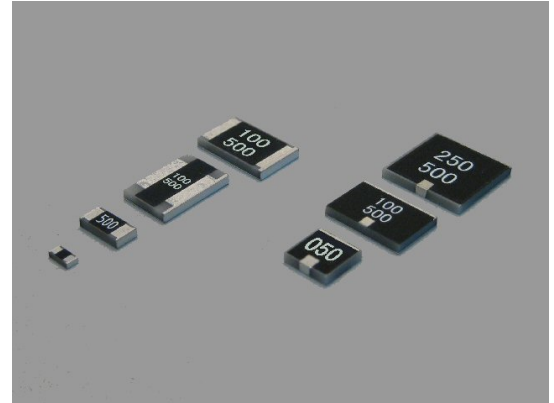

Features and Applications

- High power surface mount terminations for DC up to 6GHz applications.
- Small size and wide frequency range specifications realized with large heat conducting AlN substrate.
- Sufficient mechanical strength metallization from spattered thin film technology.
- 50ohm characteristic impedance with tolerance 1% in dc and 5W to 250W provided as standard, and other resistance and power available.
- Long life and temperature stability a result of Ni-Cr thin film technology.
- Terminations for isolator/circulators, fixed station of mobile communication electronics, and high power microwave amplifiers.

Style and Dimension

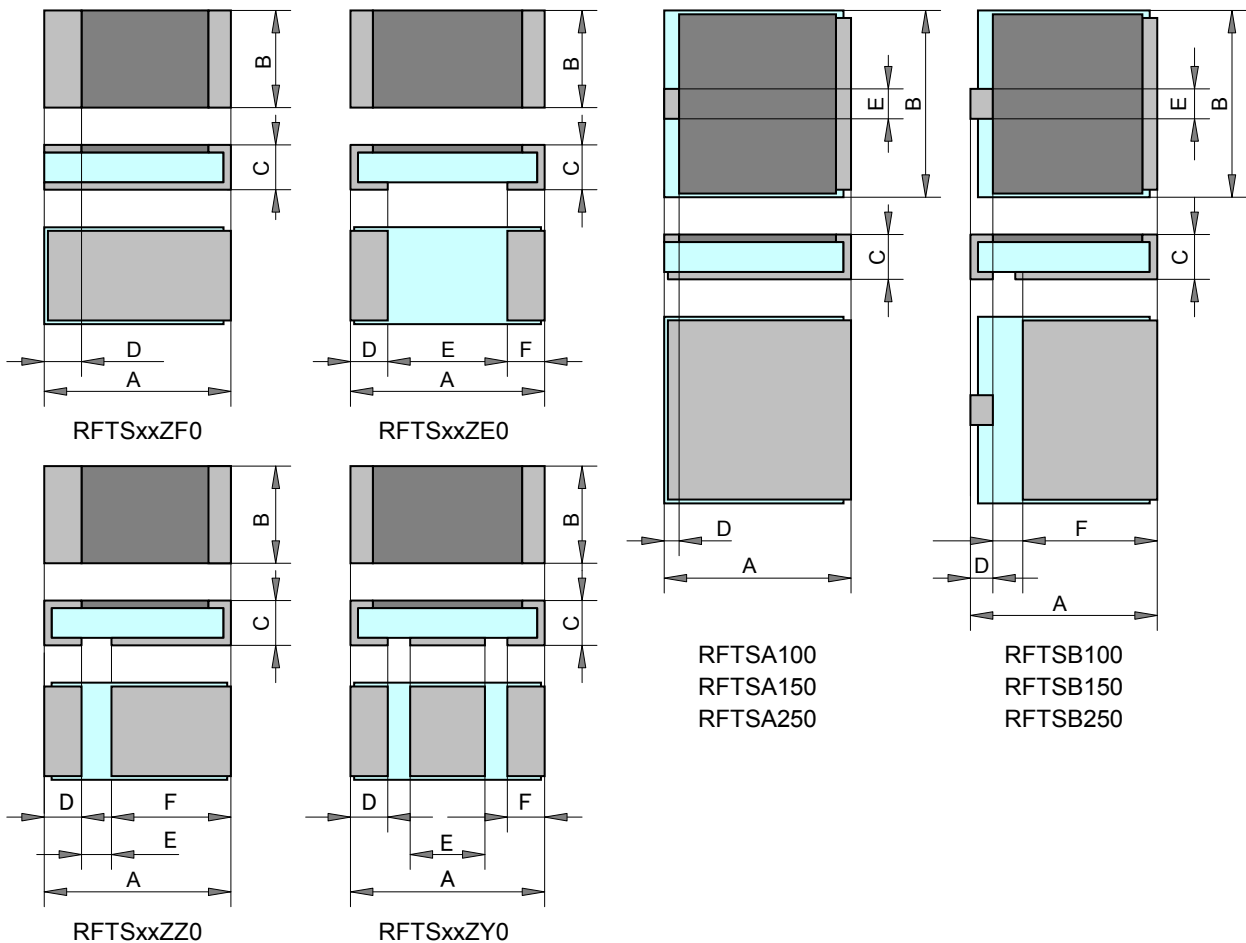

SURFACE MOUNT HIGH POWER TERMINATIONS

RFTS05, RFTS10, RFTS50, RFTS100,
RFTSA100, RFTSA150, RFTSA250, RFTSB100, RFTSB150, RFTSB250

Dimensions (mm)

Rated Power (W)	Type	Terminal	A (mm)	B (mm)	C (mm)	D (mm)	E (mm)	F (mm)
5	RFTS05	ZF0	2.54	1.27	0.63	0.70+/-0.2	-	-
5	RFTS05	ZE0	2.54	1.27	0.63	0.70+/-0.2	(1.14)	0.70+/-0.2
10	RFTS10	ZF0	5.08	2.54	1.00	1.00		-
10	RFTS10	ZE0	5.08	2.54	1.00	1.00	3.00	1.00
50	RFTS50	ZF0	5.08	5.08	1.20	1.00	-	-
50	RFTS50	ZE0	5.08	5.08	1.20	1.00	3.00	1.00
50	RFTS50	ZZ0	5.08	5.08	1.20	3.00	1.08	1.00
50	RFTS50	ZY0	5.08	5.08	1.20	100	2.00	1.00
100	RFTS100	ZF0	5.84	8.89	1.20	1.20	-	-
100	RFTS100	ZE0	5.84	8.89	1.20	1.20	2.40	1.20
100	RFTS100	ZZ0	5.84	8.89	1.20	3.40	1.20	1.20
100	RFTS100	ZY0	5.84	8.89	1.20	1.20	2.40	1.20
100	RFTSA100	---	5.84	8.89	1.20	1.20	1.20	---
100	RFTSB100	---	5.84	8.89	1.20	1.20	1.20	1.20
150	RFTSA150	---	8.89	8.89	1.20	1.20	1.20	---
150	RFTSB150	---	8.89	8.89	1.20	1.20	1.20	1.20
250	RFTSA250	---	9.52	9.52	1.20	1.20	1.20	---
250	RFTSB250	---	9.52	9.52	1.20	1.20	1.20	1.20

Ordering Information

Type	TCR	Impedance	Tolerance	Terminals & T/R	Note
RFTS50	C	500	F	ZF0	---
RFTS05	C (50ppm/K)	500 (50ohm)	F (1%)	ZF0	Bulk
RFTS10				ZE0	Bulk
RFTS50				ZZ0	Bulk
RFTS100				ZY0	Bulk
				ZF1	Tape reel
				ZE1	Tape reel
				ZZ1	Tape reel
				ZY1	Tape reel

Type	TCR	Impedance	Tolerance	Terminals & T/R	Note
RFTSA100	C	500	F	Z00	---
RFTSA100	C (50ppm/K)	500 (50ohm)	F (1%)	Z00	Bulk
RFTSB100				Z01	Tape reel
RFTSA150					
RFTSB150					
RFTSA250					
RFTSB250					

Specifications and Performances

Type	RFTS 05	RFTS 10	RFTS 50	RFTS 100	RFTS 150	RFTS 250	Conditions
Rated Power (W)	5	30	50	100	150	250	
Maximum Power (W)	10	60	100	200	300	500	Pulse<1 second
Impedance (Ohms)	50 Ohms						
TCR (ppm/C)	50						
Tolerance (%)	1.0						
Heat Resistance (C/W)	12.5	6.5	2.5	1.3	1.0	0.5	
VSWR at 1GHz	1.15	1.15	1.2	1.2	1.2	1.2	
Max Operating Temperature	-55 - 155 deg C						
Storage Temperature	-55 - 155 deg C						

SURFACE MOUNT HIGH POWER TERMINATIONS

RFTS05, RFTS10, RFTS50, RFTS100,
RFTSA100, RFTSA150, RFTSA250, RFTSB100, RFTSB150, RFTSB250

Foot Pattern

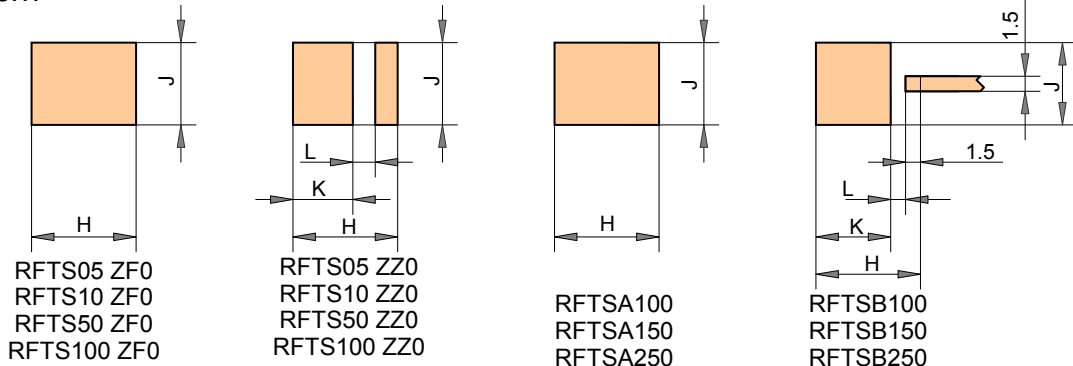

Installation

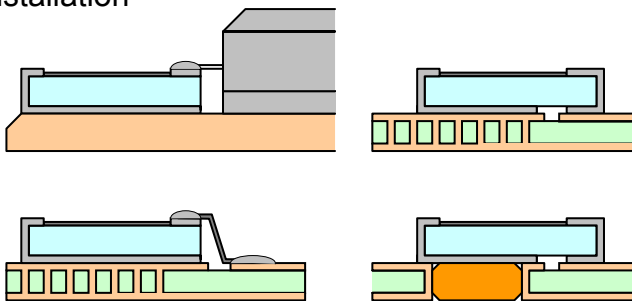

(mm)	H	J	K	L
RFTS05 ZF0	2.94	1.50	-	-
RFTS05 ZZ0	2.94	1.50	-	-
RFTS10 ZF0	5.48	2.94	-	-
RFTS10 ZZ0	5.48	2.94	(2.98)	0.5
RFTS50 ZF0	5.48	5.48	-	-
RFTS50 ZZ0	5.48	5.48	(2.98)	0.5
RFTS100 ZF0	6.24	9.29	-	-
RFTS100 ZZ0	6.24	9.29	(3.24)	0.5
RFTS150 010	6.75	9.92	--	---
RFTS150 020	6.75	9.92	(4.48)	0.5
RFTS250 010	9.92	9.92	--	-
RFTS250 020	9.92	9.92	(6.92)	0.5

Remarks

- (1) Power rating assumes that chip attached on metal insulated PC board.
- (2) Solder joint design should assure a solder thickness within 50 micron meters.
- (3) Cu inlet inserted in to circuit board will help effective heat conduction.

負荷軽減曲線 Derating Curve

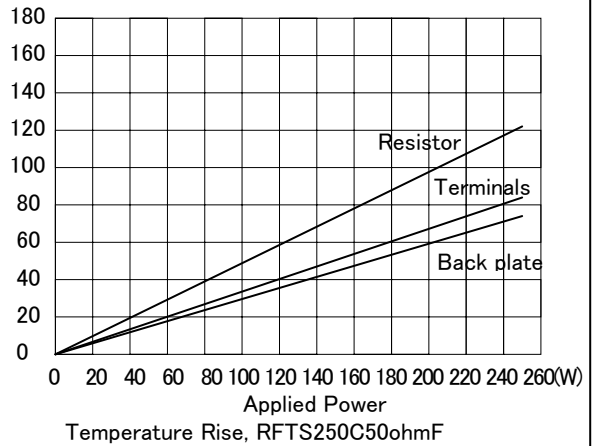
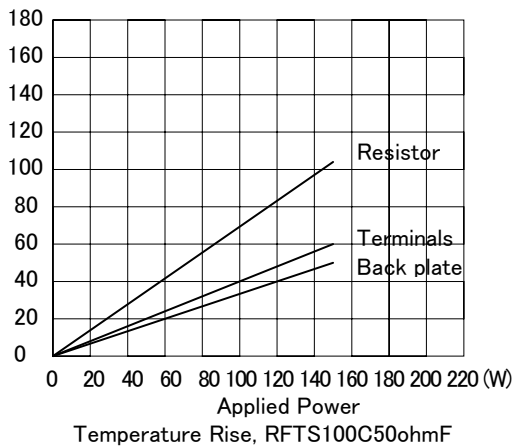
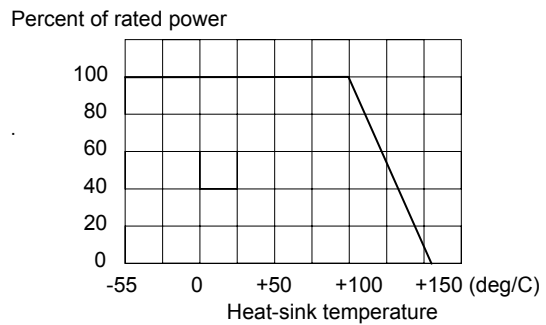

SURFACE MOUNT HIGH POWER TERMINATIONS

RFTS05, RFTS10, RFTS50, RFTS100,
RFTSA100, RFTSA150, RFTSA250, RFTSB100, RFTSB150, RFTSB250

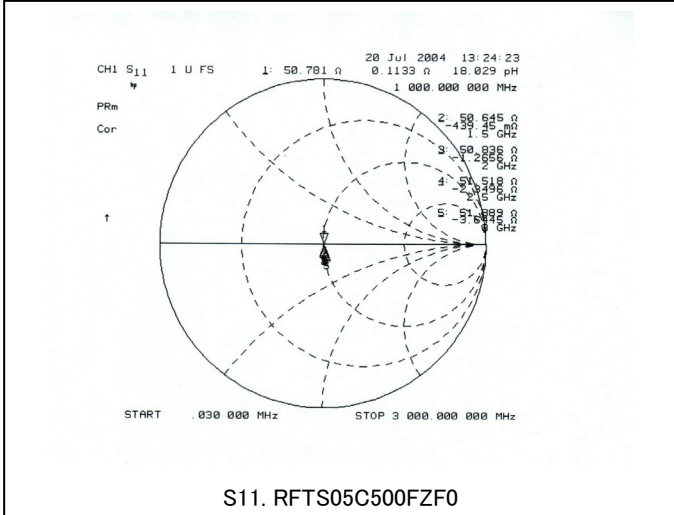

S11. RFTS05C500FZF0

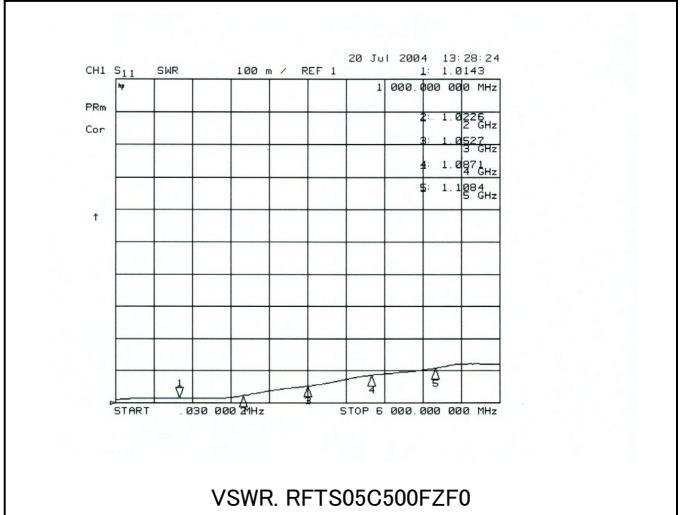

VSWR. RFTS05C500FZF0

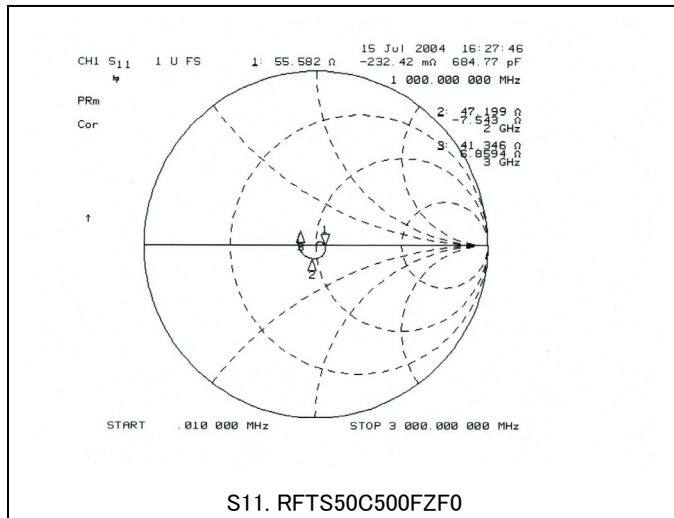

S11. RFTS50C500FZF0

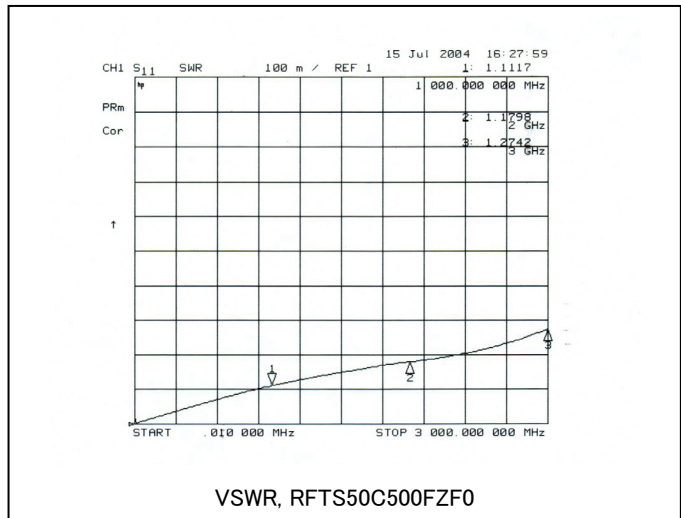

VSWR, RFTS50C500FZF0

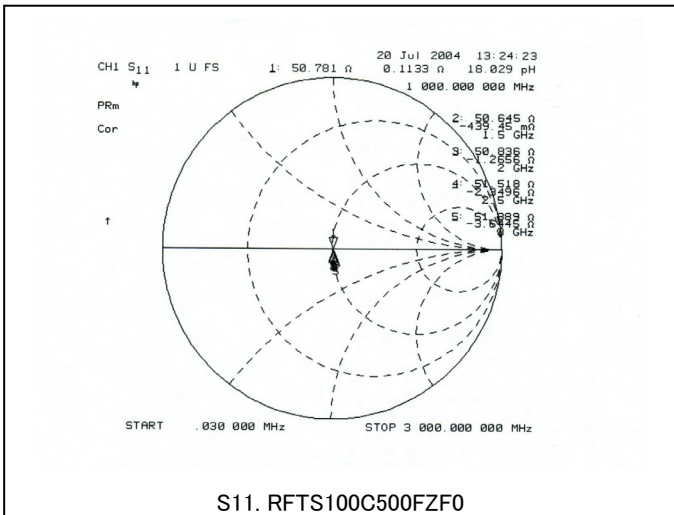

S11. RFTS100C500FZF0

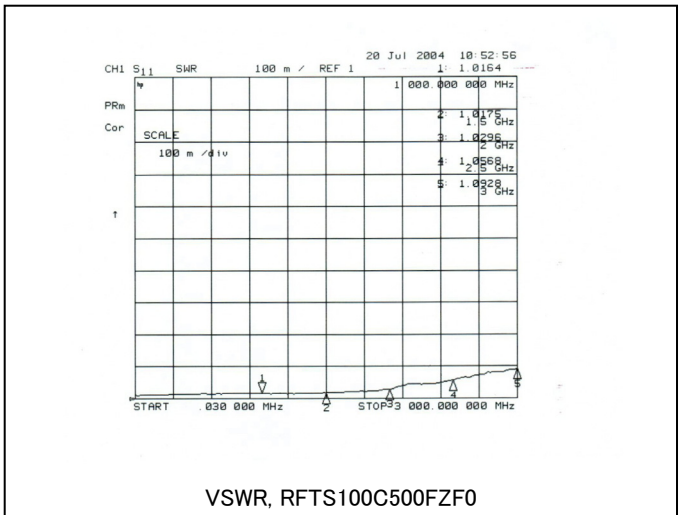

VSWR, RFTS100C500FZF0

10W, 50W, 80W, 100W, 150W, 200W
250W
FLANGED POWER TERMINATIONS, RFT

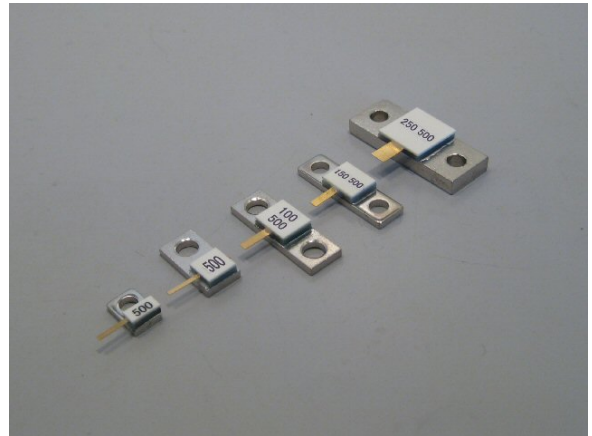

Features:

- High power flanged termination for all DC up to 4GHz applications.
- Small size and wide frequency range specifications realized with through large heat conducting AlN substrate.
- Sufficient mechanical strength metallization from spattered thin film technology.
- 50ohm resistance with tolerance 1%, and terminations include chips and many style flange provided as standard, and other resistance and power available.
- Long life and temperature stability are shown by a result of Ni-Cr thin film technology.

Applications: Termination for isolator/circulators, Fixed station of mobile communication electronics, High power microwave amplifiers

Ordering Information

Type RFT050	Style 120	TCR C	Resistance 500	Tolerance F	RoHS/Package Z00
RFT010	100	C (50ppm)	50 Ohm	F (1.0%)	Z00
RFT050	110				
RFT080	120				
RFT100	130				
RFT150	140				
RFT200					
RFT250					

Performance Specifications

Type	Rated Power (W)	Heat Resistance (deg C/W)	VSWR 500MHz	VSWR 1GHz	VSWR 2GHz
RFT010	10	6.5	---	1.15	---
RFT050	50	2.5	---	1.15	---
RFT080	80	---	---	1.20	---
RFT100	100	1.3	---	1.20	---
RFT150	150	---	---	1.30	---
RFT200	200	---	---	1.30	---
RFT250	250	0.5	---	1.30	---

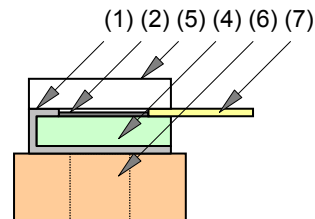

	Substance	Material
(1)	Cold end Terminal	Tin plated Ni-Cu
(2)	Resistive	Ni-Cr
(3)	Substrate	ALN
(4)	Hot end Terminal	Tin plated Ni-Cu
(5)	Cover	ALO
(6)	Flange	Ni plated Cu
(7)	Beam Lead	Au plated Cu

10W, 50W, 80W, 100W, 150W, 200W, 250W, TERMINATIONS RFT

Style and Dimension (mm)

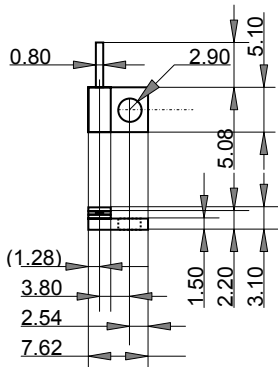

RFT010 120

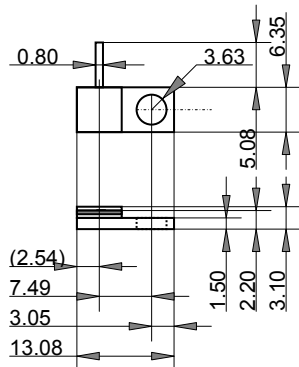

RFT050 120
RFT080 120

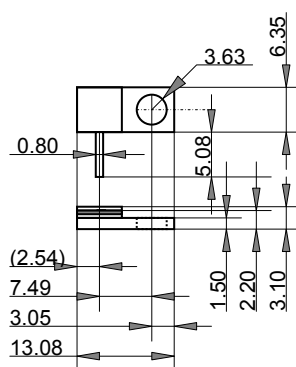

RFT050 130
RFT080 130

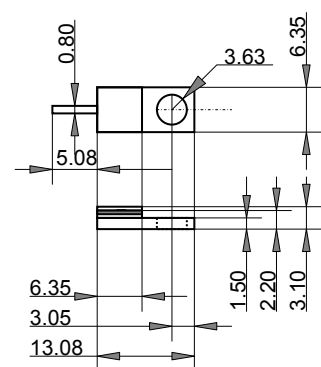

RFT050 140
RFT080 140

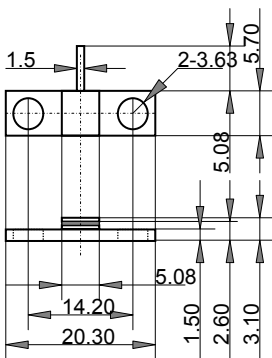

RFT050 110

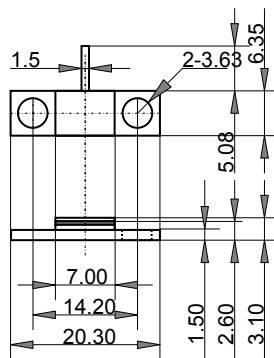

RFT100 110

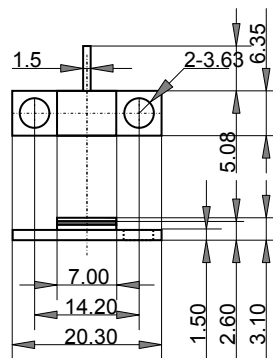

RFT150 110

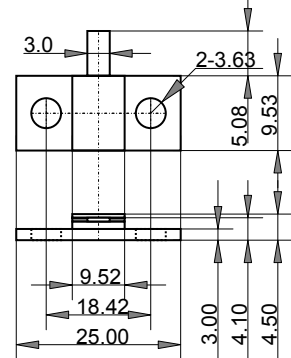

RFT250 110

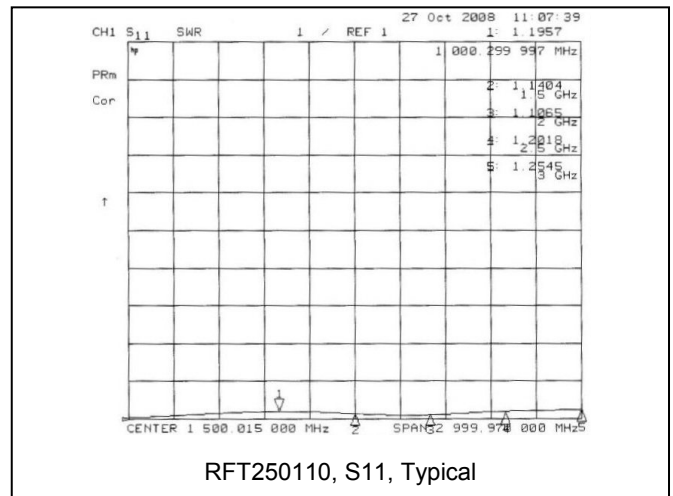
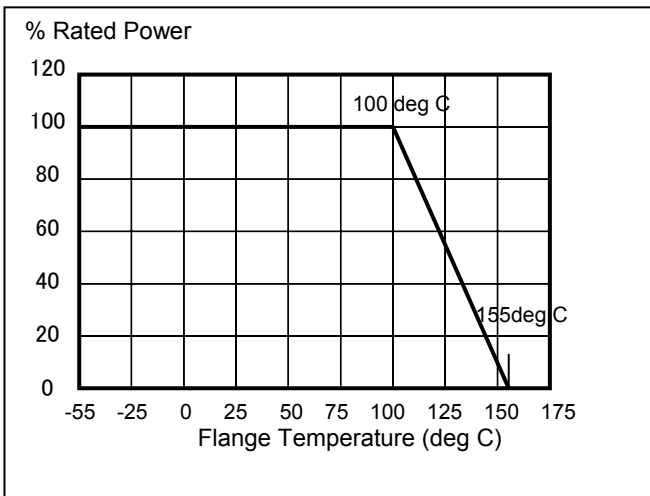

Note: RoHS 2011/65/EU conformity.
Country origin, Aomori Pref. Japan

RF CHIP ATTENUATOR, RFA001 010

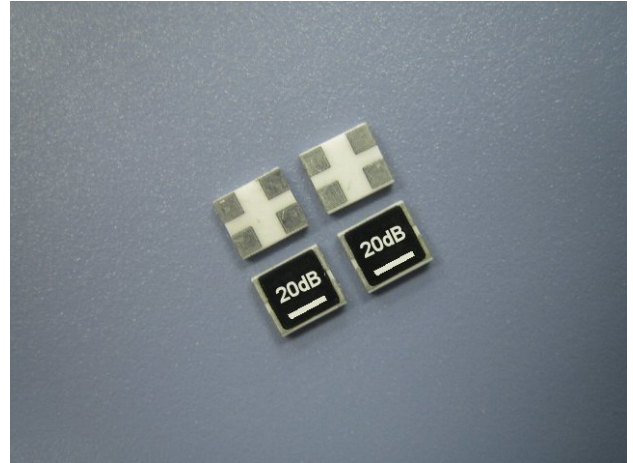

Features and Applications

2.5GHz-1W surface mount small 4mmx4mm size, attenuators of 50ohm characteristic impedance. RFA001 has 2.5GHz-1W power rating and high durability against pulse / EMI accidents in small signal applications. Long life and temperature stability of thin film technology realize better performance at a temperature range from -55C to +155C. Applications include impedance matching, gain control circuits, isolation circuits of power boost amplifiers at GHz, loss compensation of transmission line of data communication systems, detecting signal control of ATE-LSI test system-circuit board functional test systems, industrial measurement electronics, medical scientific electronics and miscellaneous communication systems.

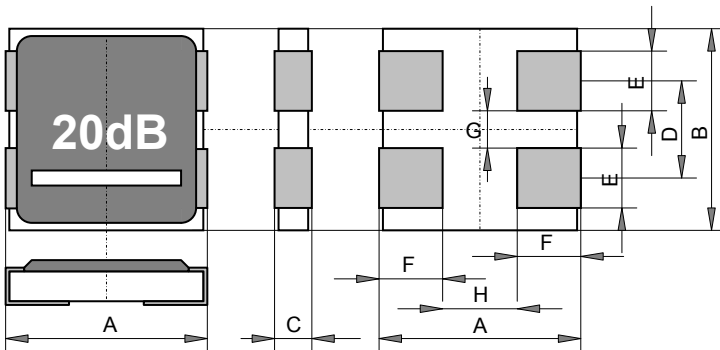

Symbol	mm	inch
A	4.0 /-0.2	0.157+/-0.008
B	4.0+/-0.2	0.157+/-0.008
C	(0.65)	(0.026)
D	2.0+/-0.1	0.079+/-0.004
E	(1.2)	(0.047)
F	1.2+/-0.1	0.047+/-0.004
G	0.8+/-0.1	0.032+/-0.004
H	1.6+/-0.1	0.063+/-0.004

Specifications and Performances

Attenuation	0, 1, 2, 3, 4, 5, 6, 7, 8, 9, 10, 20, 40* dB
Tolerance of Attenuation (at DC)	1-9dB:±0.3dB, 10dB:±0.5dB, 20dB:±1dB
Frequency Range	0-10dB: DC- 2.5GHz, 20dB: DC-600MHz
Volt Standing Wave Ratio	<1.2(0-10dB, DC-2.5GHz), (20dB, 0.6GHz)
Rating Power	1W
Characteristic Impedance	50 ohm
Tolerance of Impedance (at DC)	±2 ohm

(*) Attenuation 40dB is optional, please mail to info@nikkohm.co.jp

Structure and Material

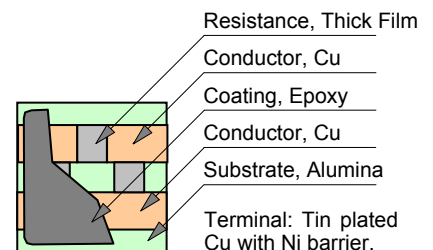

Ordering Information

Type	Attenuation	Rating Power	
RFA001010	6dB	Z00	
RFA001010	0, 1, 2, 3, 4dB	Z00	Bulk
	5, 6, 7, 8, 9 dB	Z01	Tape reel
	10, 20, 40 dB		

RF CHIP ATTENUATOR

RFA001 010

Typical S11-S21

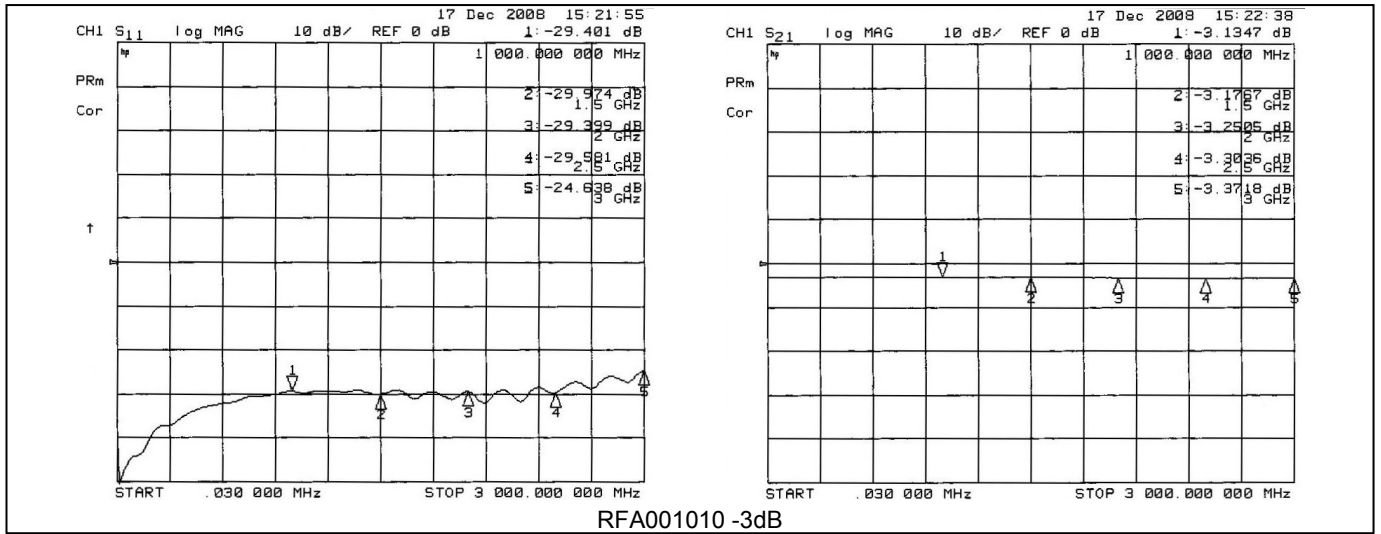

RFA001010 -3dB

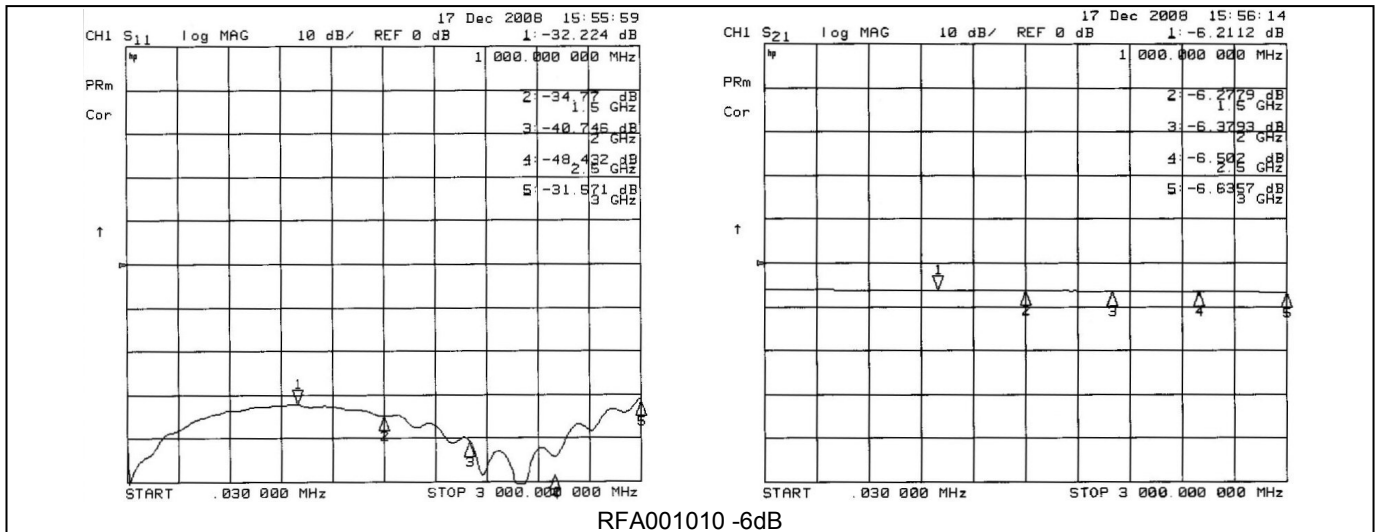

RFA001010 -6dB

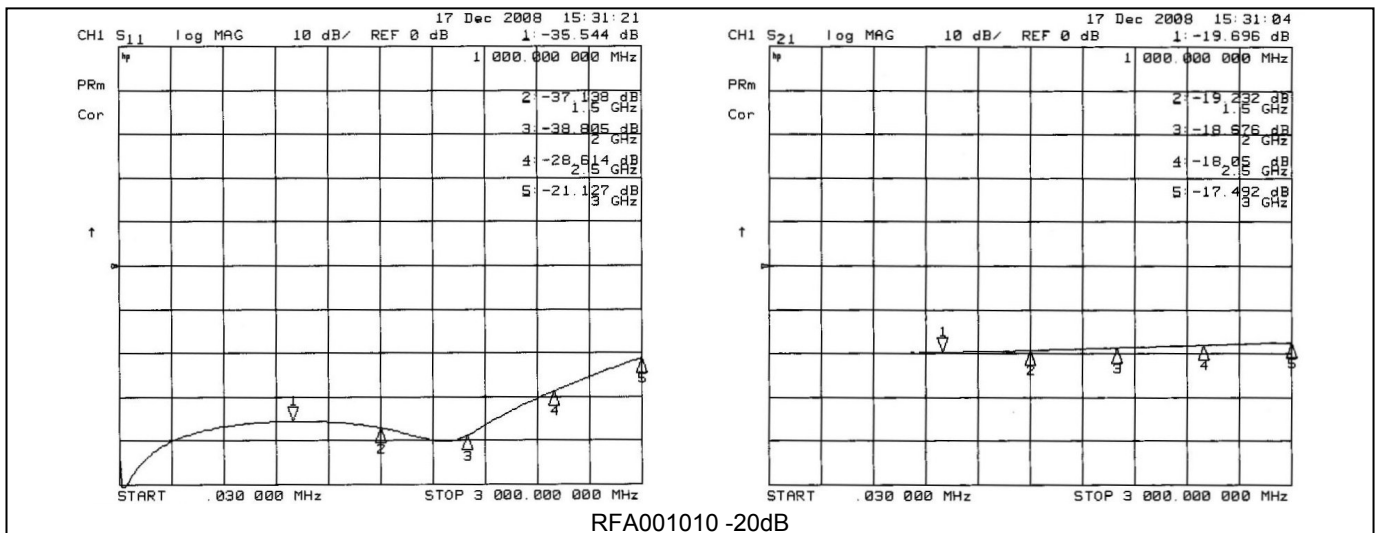

RFA001010 -20dB

Transformation: $SWR = \frac{1+|\Gamma|}{1-|\Gamma|}$ $|\Gamma| = 10^{\frac{S11}{20}}$ $|\Gamma| = \frac{SWR-1}{SWR+1}$ $S11 = -(-20 \log |\Gamma|)$

250mW
 SURFACE MOUNT 50 ohm
 RF ATTENUATORS
 RFA1206

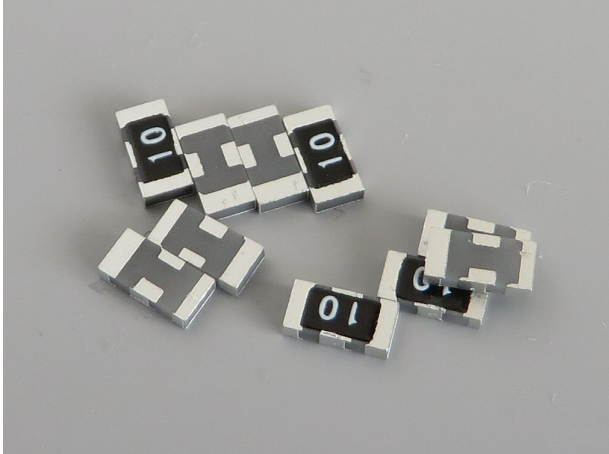

Features and Applications

Small size (1206), high performance, balanced attenuator.
 6db, 8db, 10db, 20db are available.
 250mW power handling.
 50 ohm characteristic impedance and wide frequency range
 Dc to 5.0GHz.
 Pb free, RoHS compliant and BeO free configuration.
 Long life and temperature stability by thin film technology
 Applications include power detect circuit of isolator, gain control circuits, isolation circuits of power boost amplifiers at GHz, loss compensation of transmission line of data communication systems, detecting signal control of ATE-LSI test system-circuit board functional test systems, industrial measurement electronics, medical scientific electronics and aero space.

Dimensions and Materials

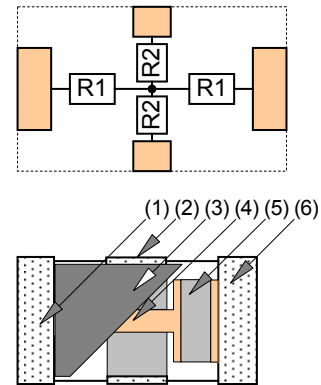
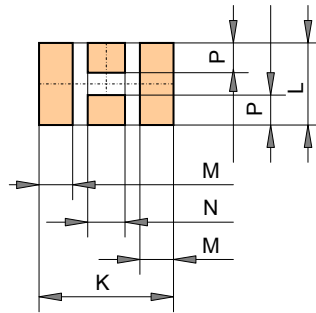
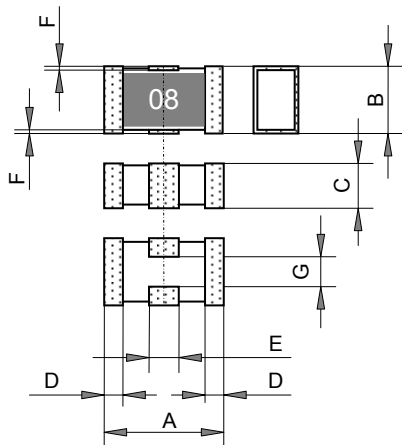

	inch	mm	Tol (mm)
A	0.126	3.20	+/-0.08
B	0.063	1.60	+/-0.08
C	0.025	0.63	+/-0.08
D	0.020	0.51	+/-0.08
E	0.032	0.81	+/-0.08
F	0.009	0.23	+/-0.08
G	(0.032)	(0.81)	+/-0.08

	inch	mm	Tol (mm)
K	0.142	3.60	+/-0.08
L	0.079	2.00	+/-0.08
M	0.036	0.90	+/-0.08
N	0.039	1.00	+/-0.08
P	0.031	0.80	+/-0.08

	Substances	Materials
(1)	Input Conductor	Cu-Ni-Tin plating
(2)	Side Conductor	Cu-Ni-Tin plating
(3)	Passivation	Epoxy resin
(4)	Inside Conductor	Ni-Cr Cu sputtering
(5)	Thin Film Resistor	Ni-Cr alloy
(6)	Output Conductor	Cu-Ni-Tin plating

Note: Side conductor is build on ALN substrate and sputtering Ni-Cr, sputtering Cu, electro-plated Ni, electro-plated Tin.

SURFACE MOUNT RF ATTENUATORS, 250mW

RFA1206

Ordering Information

Type	---	Attenuation	Code	Note
RFA1206	---	20dB	Z01	
RFA1206	---	6dB	Z00	Bulk
		8dB	Z01	Tape and reel
		10dB		
		20dB		

Specifications and Performances

Items	Specifications	Conditions
Attenuation	6db, 8db, 10db, 20db	
Attenuation tolerance	+/-0.4dB	Output DC volt in terminating out put with resistor when stable 1V DC volt source connect to input.
Characteristic Impedance	50 Ohms	
Tolerance of Impedance	+/- 2%	Input DC resistance in terminating output with resistor.
TC of Impedance	+/- 50ppm/°C	TC of input DC resistance in terminating output with resistor.
TC of Attenuation	+/- 50ppm/°C	TC of output DC volt in terminating out put with resistor when stable 1V DC volt source connect to input.
Rating Power	250 mW	Input Power
Rating Temperature	-55-100 °C	
Soldering Heat	+/- 1%	350C, 3 seconds dipping.
Soldering capability	95% covered	
Humidity	+/- 1% impedance	Input DC resistance change Under condition of 40C temp and 90-95%RH, rating power ON-90min, OFF-30min, 1000h
Load Life	+/- 1% impedance	Input DC resistance change. Under condition of 70C temp, rating power ON-90min, OFF-30min, 1000h
Operating Temperature	-55 °C - +155 °C	
Storage Temperature	-55 °C - +80 °C	

Derating

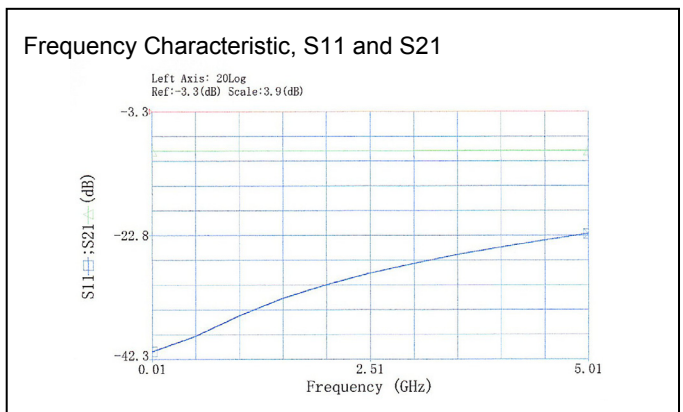
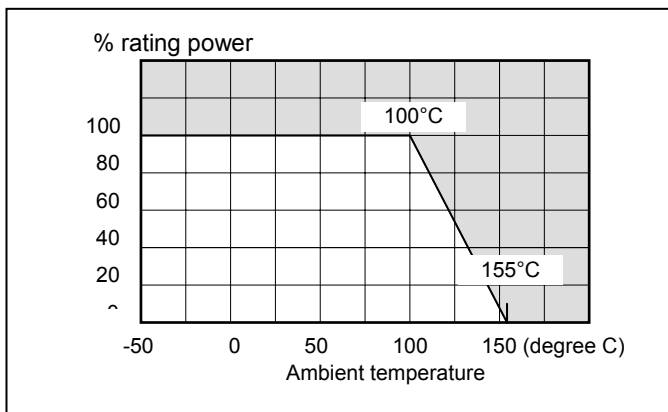

Note: Transformation: $VSWR = \frac{1+|\Gamma|}{1-|\Gamma|}$ $|\Gamma| = 10^{\frac{S11}{20}}$ $|\Gamma| = \frac{VSWR - 1}{VSWR + 1}$ $S11 = -(-20 \log |\Gamma|)$

20160201

10W-150W
 SURFACE MOUNT 50 ohm
 RF POWER ATTENUATORS
 RFA010, RFA020, RFA040,
 RFA100, RFA150

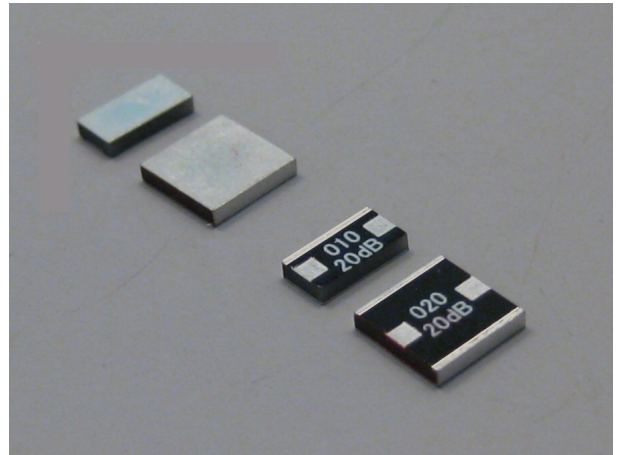

Features and Applications

RFA010 to RFA150, 10W to 150W, surface mount small size attenuators of 10dB, 20dB and 30dB attenuation, 50ohm characteristic impedance for DC to 3GHz.

Pb free and BeO free configuration.

Long life and temperature stability of thin film technology realize better performance at a temperature range from -55C to +155C.

Applications include power detect circuit of isolator, gain control circuits, isolation circuits of power boost amplifiers at GHz, loss compensation of transmission line of data communication systems, detecting signal control of ATE-LSI test system-circuit board functional test systems, industrial measurement electronics, medical scientific electronics and many communication systems.

Dimensions (mm)

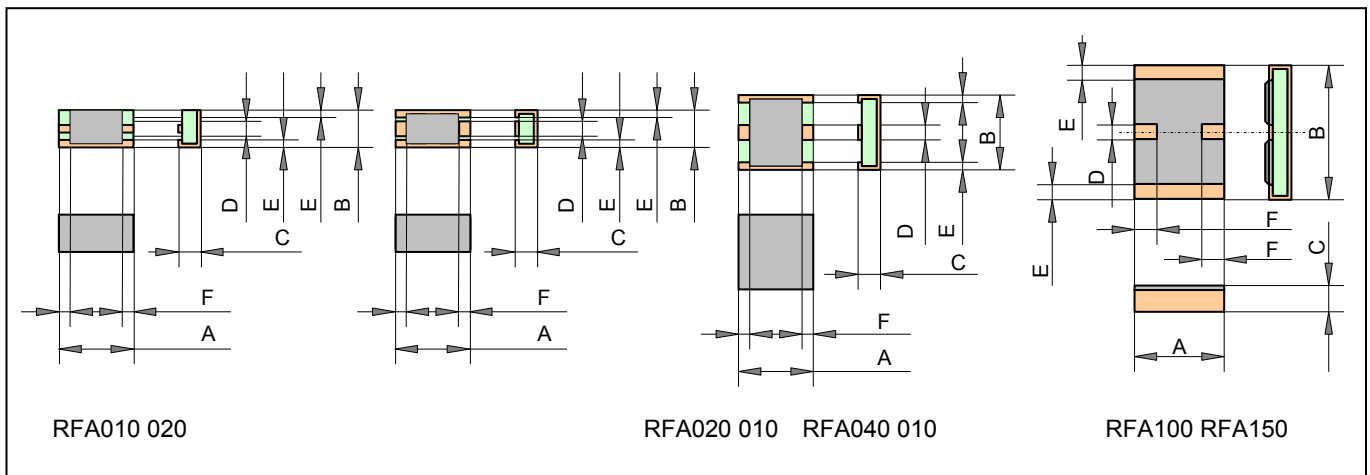

P/N	A	B	C	D	E	F	old p/n
RFA010 020	5.08+/-0.25	2.54+/-0.25	1.1 max.	1.0+/-0.3	0.2+/-0.1	(1.0)	Tee
RFA020 010	5.08+/-0.25	5.08+/-0.25	1.1 max.	1.0+/-0.3	0.2+/-0.1	(1.0)	PAI
RFA020 020	5.08+/-0.25	5.08+/-0.25	1.1 max.	1.0+/-0.3	0.2+/-0.1	(1.0)	Tee
RFA040 010	5.08+/-0.25	5.08+/-0.25	1.1 max.	1.0+/-0.3	0.2+/-0.1	(1.0)	PAI
RFA100 030	5.72+/-0.25	8.90+/-0.25	1.1 max.	1.1+/-0.3	0.3+/-0.1	(1.1)	RFAS100-1
RFA150 030	6.35+/-0.25	9.52+/-0.25	1.1 max.	1.1+/-0.3	0.3+/-0.1	(1.1)	RFAS150-1

SURFACE MOUNT RF POWER ATTENUATORS, 10W-150W

RFA010, RFA020, RFA040, RFA100, RFA150

Ordering Information

Type	Style	---	Attenuation	Code	Note
RFA100	030	---	20dB	Z01	
RFA010	010	---	10dB	Z00	Bulk
RFA020	020		20dB	Z01	Tape Reel
RFA040	030		30dB		
RFA100					
RFA150					

Specifications and Performances

Model	Rated Power	Schematic	Impedance*2	Attenuations*1	Frequency	Note
RFA010 010	10 W	Balanced PAI	50 ohm	3, 4, 5, 6, 7, 8, 9, 10, 20, 30 dB	DC-6.0GHz	
RFA010 020	10 W	Unbalanced Tee	50 ohm	10dB, 20dB, 30dB	DC-3.0GHz	
RFA020 010	20 W	Balanced PAI	50 ohm	10dB, 20dB, 30dB	DC-3.0GHz	
RFA020 020	20 W	Balanced Tee	50 ohm	10dB, 20dB, 30dB	DC-3.0GHz	
RFA040 010	40 W	Balanced PAI	50 ohm	10dB, 20dB, 30dB	DC-3.0GHz	
RFA100 030	100 W	Balanced PAI	50 ohm	10dB, 20dB, 30dB	DC-3.0GHz	
RFA150 030	150 W	Balanced PAI	50 ohm	10dB, 20dB, 30dB	DC-3.0GHz	

(*1) Attenuation Tolerance at DC are 20, 30dB: +/-0.4dB.

(*2) Impedance tolerance at DC are 50 ohm +/- 2%.

Note 1: Rating wattage of RFA100 and RFA150 assume that the chip attached on proper heat-sink by solder.

Specifications

Items	Specifications	Conditions
Tolerance of Impedance	+/- 2%	Input DC resistance in terminating output with resistor.
Tolerance of Attenuation	See above note *1.	Output DC volt in terminating out put with resistor when stable 1V DC volt source connect to input.
TC of Impedance	+/- 50ppm/C	TC of input DC resistance in terminating output with resistor.
TC of Attenuation	+/- 50ppm/C	TC of output DC volt in terminating out put with resistor when stable 1V DC volt source connect to input.
Rating Temperature	-55-100 C	
Soldering Heat	+/- 1%	350C, 3 seconds dipping.
Soldering capability	95% covered	
Humidity	+/- 1% impedance	Input DC resistance change Under condition of 40C temp and 90-95%RH, rating power ON-90min, OFF-30min, 1000h
Load Life	+/- 1% impedance	Input DC resistance change. Under condition of 70C temp, rating power ON-90min, OFF-30min, 1000h
Operating Temperature	-55 deg C - +155 deg C	
Storage Temperature	-55 deg C - +155 deg C	

Derating

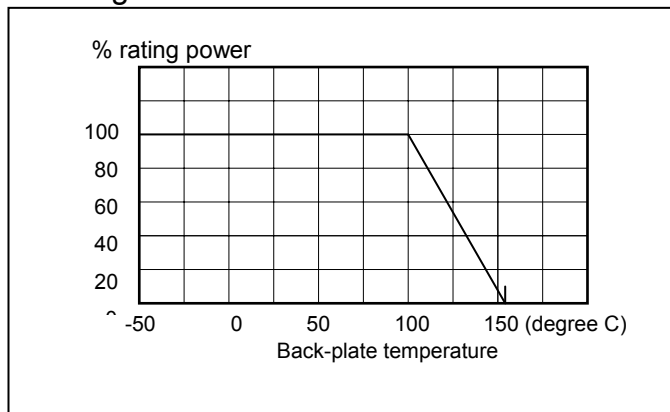

Note

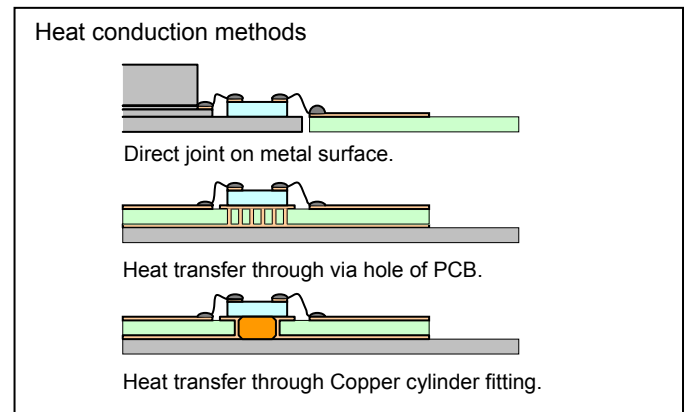

SURFACE MOUNT RF POWER ATTENUATORS, 10W-150W

RFA010, RFA020, RFA040, RFA100, RFA150

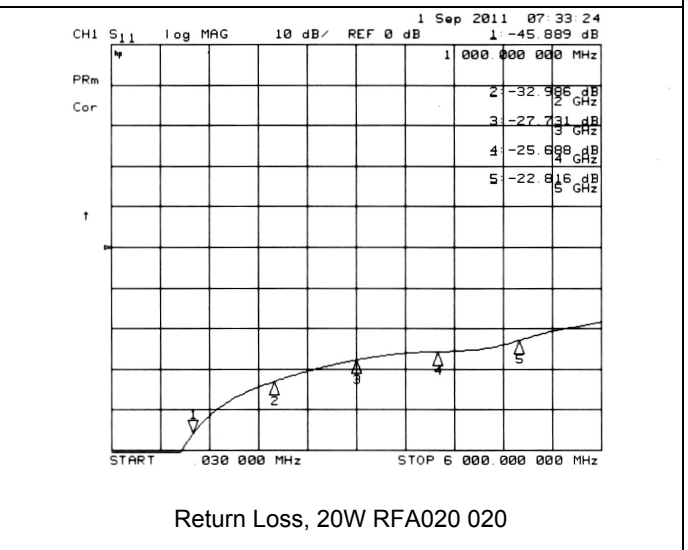
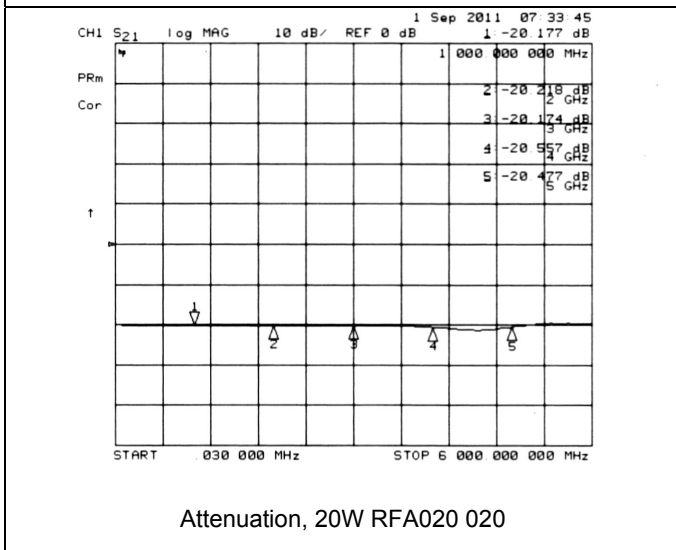
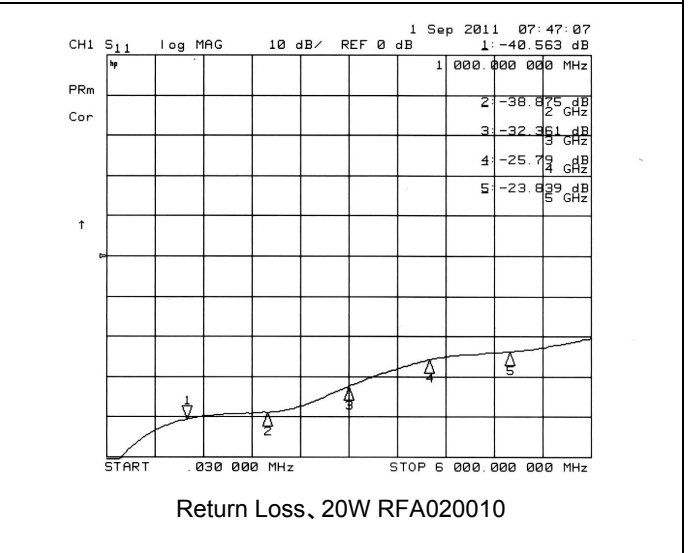
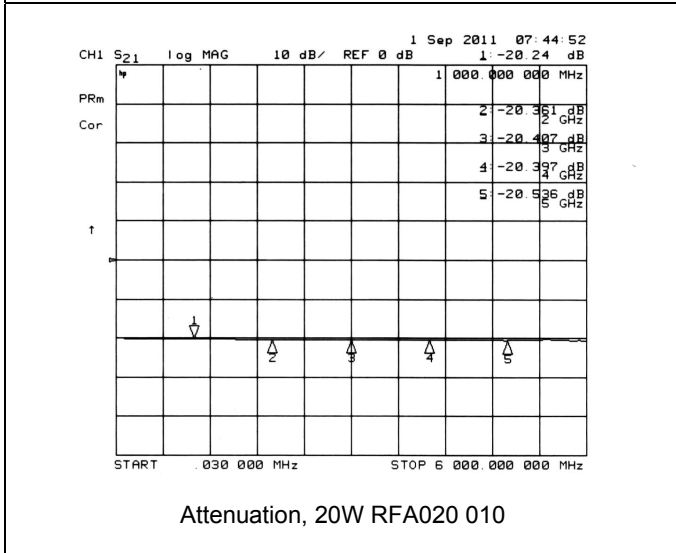
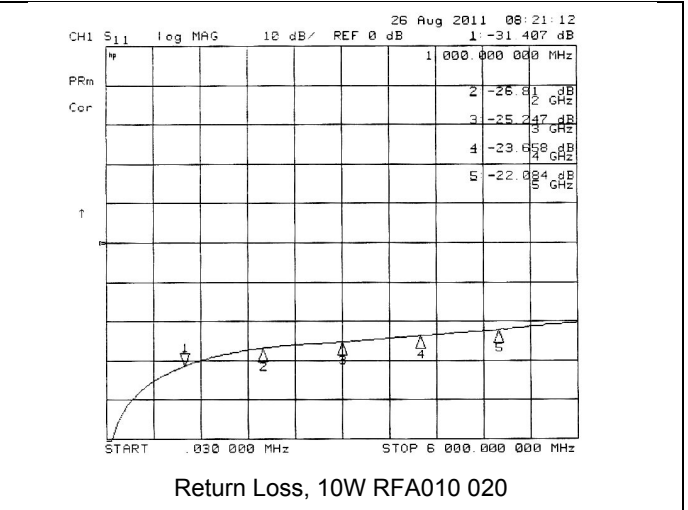
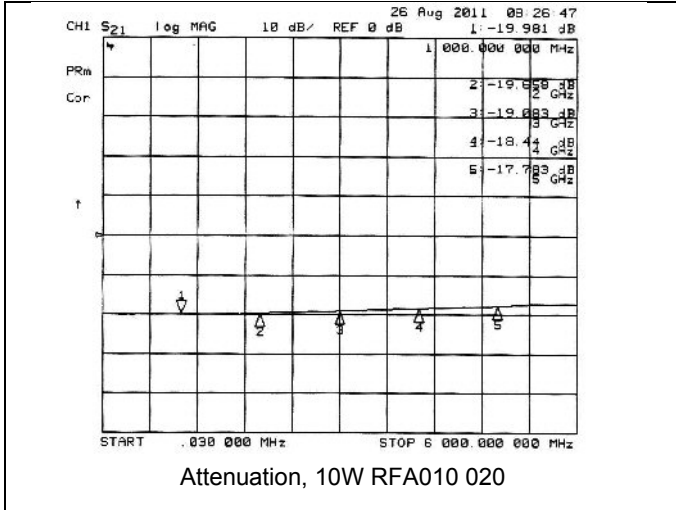

100W
 FLANGE MOUNT
 RF POWER ATTENUATORS
 RFA100 110

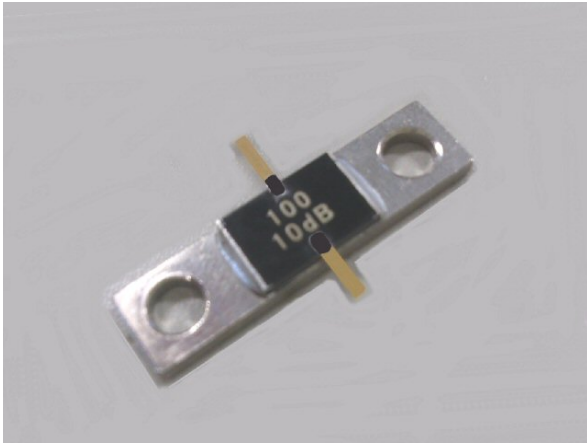

Features and Applications

RFA100 110, 100W, flange mount small size attenuators in range of of 3dB to 30 dB attenuation, 50ohm characteristic impedance for DC to 3GHz.

RFA100 110 is RoHS and BeO free configuration with ALN.

RFA100 110 has soft Cu beam leads

Long life and temperature stability of thin film technology realize better performance at a temperature range from -55°C to +155°C.

Applications include power amplifiers at GHz, loss compensation of transmission line of data communication systems, detecting signal control of ATE-LSI test system-circuit board functional test systems, industrial measurement electronics, medical scientific electronics.

Dimensions (mm) and Materials

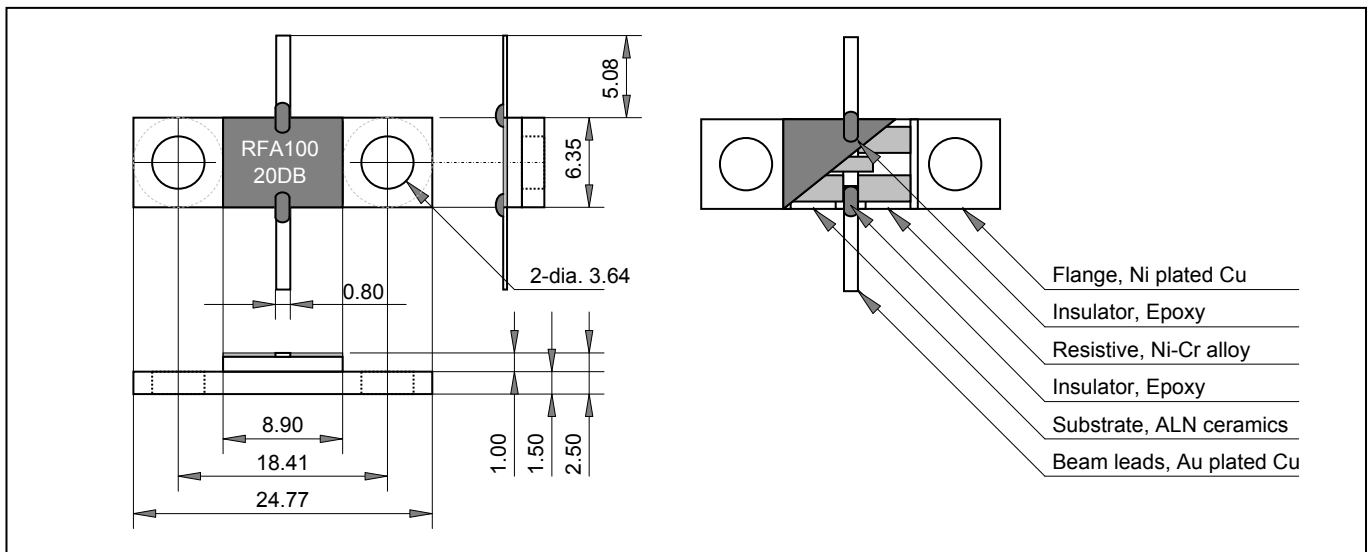

Ordering Information

Type RFA100 110	Attenuation 20dB	Tolerance of Imp. G	Packaging Z00	Note
RFA100 110	3dB 6dB 10dB 20dB 30dB	G (2%)	Z00 RoHS Tray Package	

100W
FLANGE MOUNT RF POWER ATTENUATORS

RFA100 110

Specifications

Type	RFA100 110	Note
Rated Power, input power	100W	-55°C to +100°C
Rated Operating Temperature	100 deg C	With heat sink
Characteristic Impedance	50 ohm	at dc
Tolerance, Impedance	+/- 2.0%	
TCR, Impedance	+/- 50 ppm/°C	
Attenuation	3, 6, 10, 20, 30 dB	at dc
Tolerance, Attenuation	See table 1	20dB & 30dB, +/-0.4dB
TCR, Attenuation	+/- 50 ppm/°C	
VSWR	See table 2	
Operating Temp. Range	-55 °C - +155 °C	
Storage Temp. Range	-55 °C - +155 °C	

Note 1: Rating wattage of RFA100 110 assumes that the chip attached on proper heat-sink by screw.

Note 2: RFA100 110 is compliance with RoHS.

Note 3: When another attenuation is required please call factory, info@nikkohm.co.jp

Performances

Items	Specifications	Conditions
Soldering Heat	+/- 1%	350°C, 3 seconds dipping.
Soldering Capability	95% covered	
Humidity	+/- 1% impedance	Input DC resistance change Under condition of 40C temp and 90-95%RH, rating power ON-90min, OFF-30min, 1000h
Load Life	+/- 1% impedance	Input DC resistance change. Under condition of 70C temp, rating power ON-90min, OFF-30min, 1000h

Derating

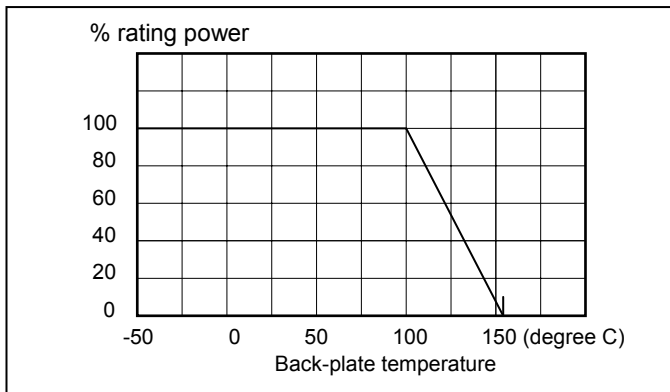

RF Characteristic (S21), typical

GHz	0.1	1.0	1.5	2.0	2.5	3.0
RFA100110 20DB	20.0	20.0	20.0	20.1	20.2	20.3
RFA100110 30DB	30.0	30.0	29.9	30.0	30.0	30.0

RF Characteristics (S11), typical

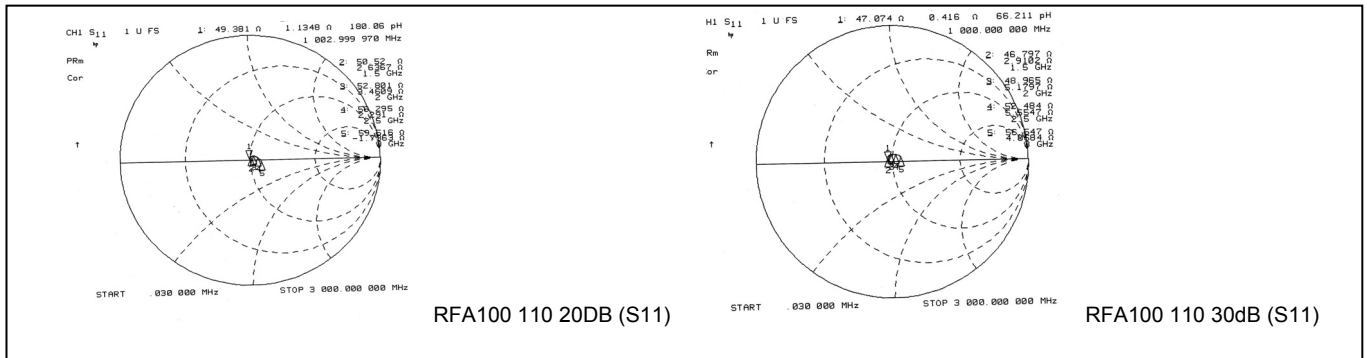

150W
 FLANGE MOUNT
 RF POWER ATTENUATORS
 RFA150 110

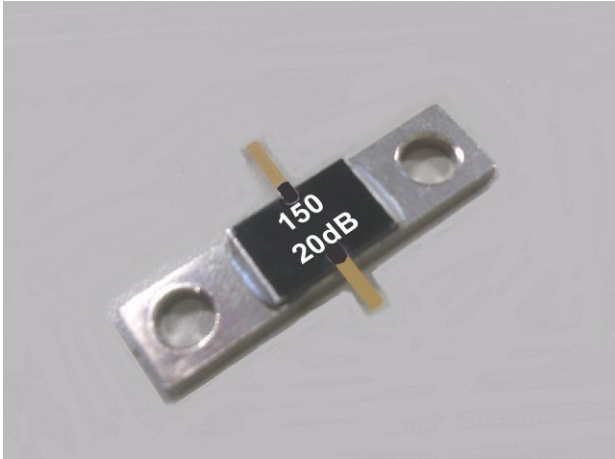

Features and Applications

RFA150 110, 150W, flange mount small size attenuators in range of of 3dB to 30 dB attenuation, 50ohm characteristic impedance for DC to 3GHz.
 RFA150 110 is RoHS and BeO free configuration with ALN.
 RFA150 110 has soft Cu beam leads
 Long life and temperature stability of thin film technology realize better performance at a temperature range from -55°C to +155°C.
 Applications include power amplifiers at GHz, loss compensation of transmission line of data communication systems, detecting signal control of ATE-LSI test system-circuit board functional test systems, industrial measurement electronics, medical scientific electronics.

Dimensions (mm) and Materials

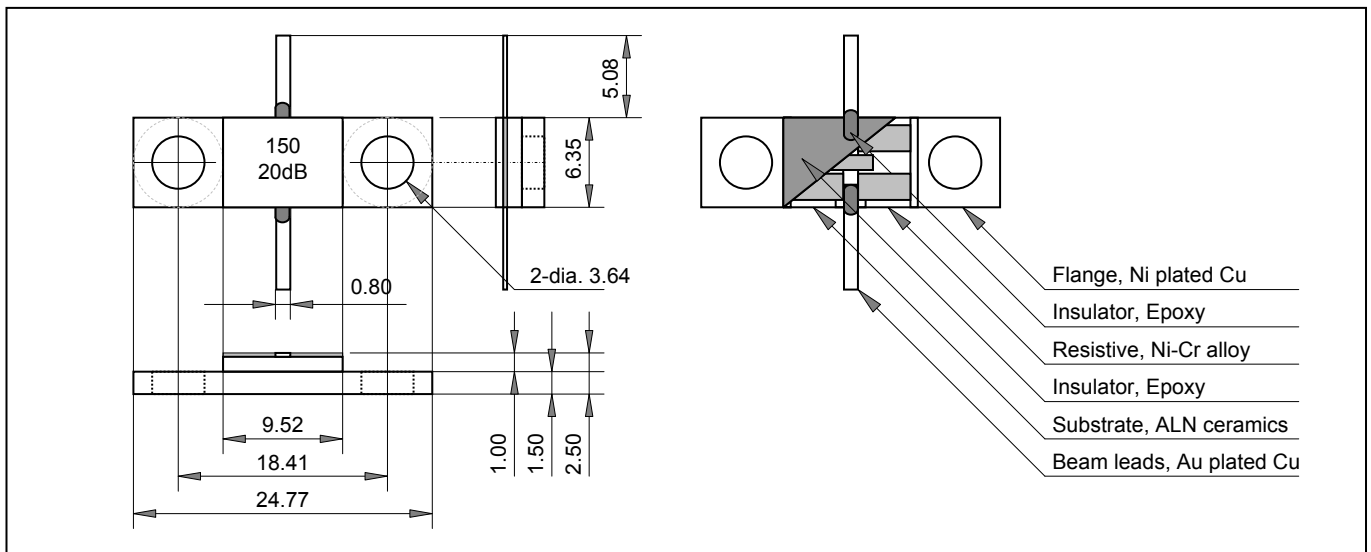

Ordering Information

Type RFA150 110	Attenuation 20dB	Tolerance of Imp. G	Packaging Z00	Note
RFA150 110	3dB 6dB 10dB 20dB 30dB	G (2%)	Z00 RoHS Tray Package	

150W
FLANGE MOUNT RF POWER ATTENUATORS

RFA150 110

Specifications

Type	RFA150 110	Note
Rated Power, input power	150W	-55°C to +100°C
Rated Operating Temperature	100 deg C	With heat sink
Characteristic Impedance	50 ohm	at dc
Tolerance, Impedance	+/- 2.0%	
TCR, Impedance	+/- 50 ppm/°C	
Attenuation	3, 6, 10, 20, 30 dB	at dc
Tolerance, Attenuation	See table 1	20dB & 30dB, +/-0.4dB
TCR, Attenuation	+/- 50 ppm/°C	
VSWR	See table 2	
Operating Temp. Range	-55 °C - +155 °C	
Storage Temp. Range	-55 °C - +155 °C	

Note 1: Rating wattage of RFA150 110 assumes that the chip attached on proper heat-sink by screw.

Note 2: RFA150 110 is compliance with RoHS.

Note 3: When another attenuation is required please call factory, info@nikkohm.co.jp

Performances

Items	Specifications	Conditions
Soldering Heat	+/- 1%	350°C, 3 seconds dipping.
Soldering Capability	95% covered	
Humidity	+/- 1% impedance	Input DC resistance change Under condition of 40C temp and 90-95%RH, rating power ON-90min, OFF-30min, 1000h
Load Life	+/- 1% impedance	Input DC resistance change. Under condition of 70C temp, rating power ON-90min, OFF-30min, 1000h

Derating

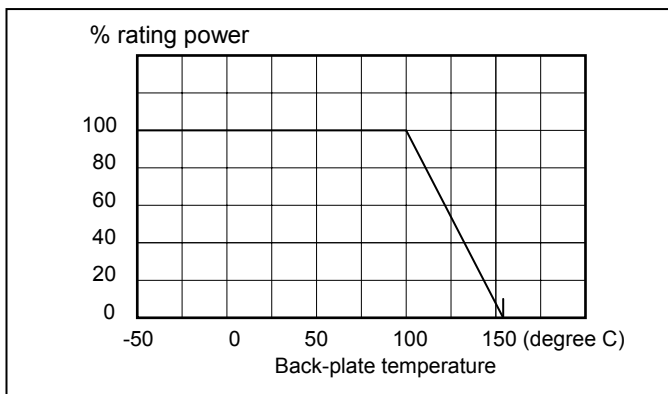

RF Characteristic (S21), typical

GHz	0.1	1.0	1.5	2.0	2.5	3.0
RFA150110 20DB	20.0	20.0	20.0	20.1	20.2	20.3
RFA150110 30DB	30.0	30.0	29.9	30.0	30.0	30.0

高周波特性 RF Characteristics (S11), typical

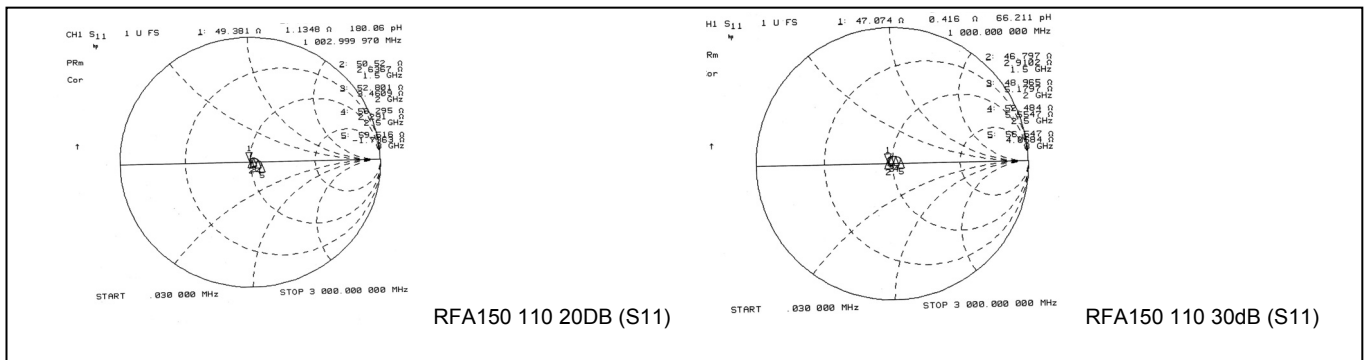

VHF/UHF THROUGH-HOLE ATTENUATOR

RFA-50T, RFA-75T,
RFA-300T, RFA-600T

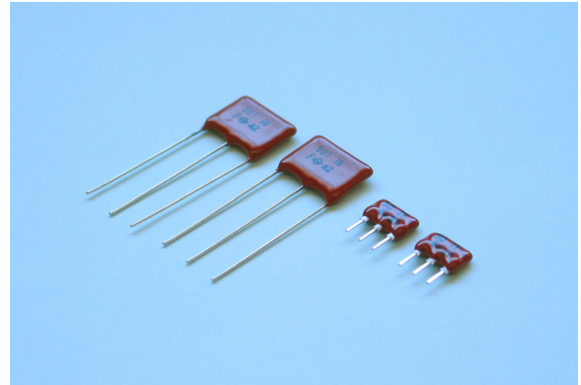

Features and Applications

RF attenuators with 50ohm, 75ohm, 300ohm and 600ohm characteristic impedance and T- schematic. For through hole applications of SIP.

Long life and temperature stability a result of Ni-Cr thin film and alumina substrates. RFA series useful in isolation circuits, data transmission, mobile, RF applications and measurements

Specifications and Performances

Model	Type	Characteristic Impedance	Attenuation	Frequency	Rate Power
RFA-50TF	T-SIP 2.54pitch leads	50 ohm	2,3,4,5,6,7,8,9,10,16, 20,30,32 dB	DC-100MHz	0.25W
RFA-75TF	T-SIP 2.54pitch leads	75 ohm	2,3,4,5,6,7,8,9,10,16, 20,30 dB	DC-100MHz	0.25W
RFA-300TF	T-SIP 2.54pitch leads	300 ohm	2,3,4,5,6,7,8,9,10,16, 20,30 dB	DC-100MHz	0.25W
RFA-600TF	T-SIP 2.54pitch leads	600 ohm	2,3,4,5,6,7,8,9,10,16, 20,30 dB	DC-100MHz	0.25W
RFA-50T	T-SIP 5.0pitch leads	50 ohm	2,3,4,5,6,7,8,9,10,16, 20,30,32 dB	DC-100MHz	0.50W
RFA-75T	T-SIP 5.0pitch leads	75 ohm	2,3,4,5,6,7,8,9,10,16, 20,30 dB	DC-100MHz	0.50W
RFA-300T	T-SIP 5.0pitch leads	300 ohm	2,3,4,5,6,7,8,9,10,16, 20,30 dB	DC-100MHz	0.50W
RFA-600T	T-SIP 5.0pitch leads	600 ohm	2,3,4,5,6,7,8,9,10,16, 20,30 dB	DC-100MHz	0.50W

Note: 1db and 40dB are optional, consult factory.

Ordering Information

Model	Attenuation	Imp. Tolerance	RoHS	Note
RFA-50TF	6dB	F (1%)	Z00	---
RFA-50TF	2dB	F (+/-1%)	Z00	---
RFA-75TF	3dB			
RFA-300TF	4dB			
RFA-600TF	5dB, 6dB, 7dB			
	8dB, 9dB			
RFA-50T	10dB			
RFA-75T	16dB			
RFA-300T	20dB			
RFA-600T	30dB			
	32dB(*)			

(*): Attenuation 32dB is optional only for RFA50TF and RFA50T.

Pin Assignment

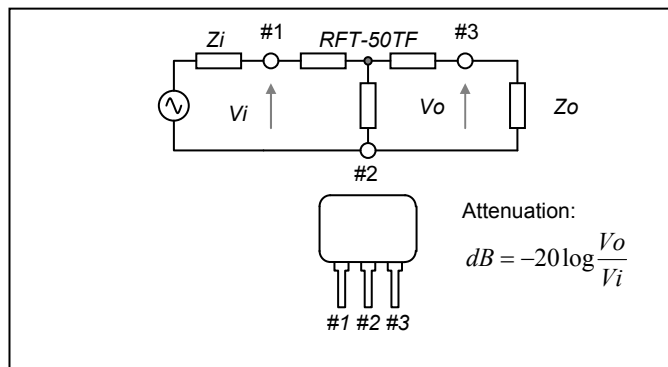

Power Derating

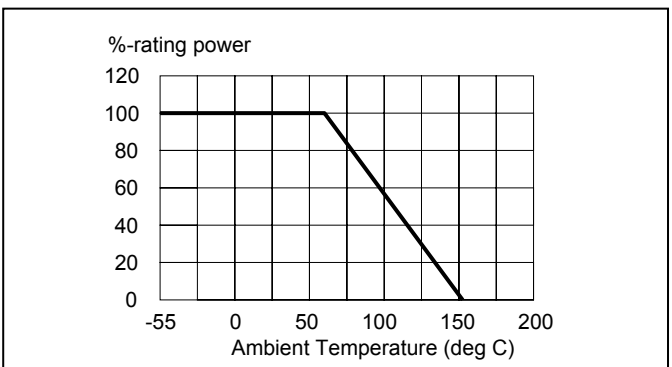

VHF/UHF THROUGH-HOLE ATTENUATORS

RFA-50T, RFA-75T, RFA-300T, RFA-600T

Dimensions

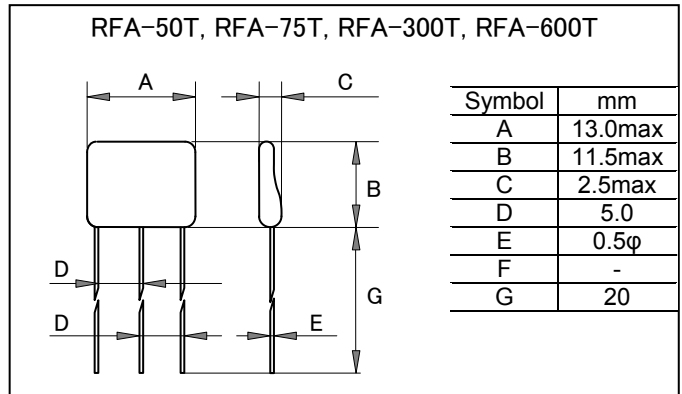
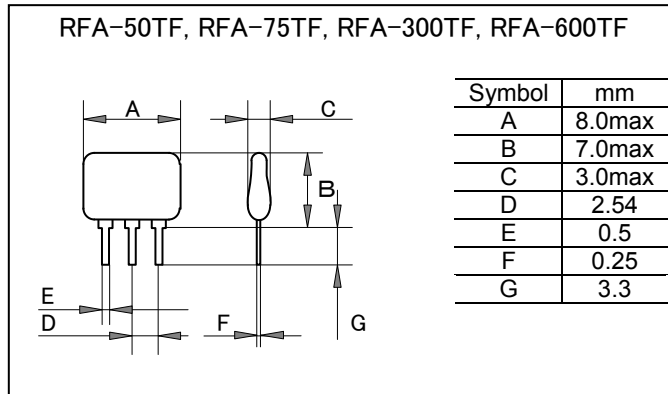

Performance

Items	Specifications	Test Methods
Tolerance of Impedance	+/-1% (F)	Input dc resistance in terminating output port with precision resistor.
Tolerance of Attenuation	+/-1%	Output dc volt in terminating output port with precision resistor when 1V stable dc source connect to input port.
TCR of Impedance	+/-50ppm/deg C	TC of input DC resistance in terminating output port with precision resistor
TCR of Attenuation	+/-50ppm/deg C	Output dc volt TC in terminating output port with precision resistor when 1V stable dc source connect to input port.
Rating Temperature	+70 deg C	-55 deg C to +70 deg C at rating power (Operating: +155deg C)
Soldering Heat	+/-1%	350°C, 3 seconds, dipping
Solder-ability	75% Covered	350°C, 3 seconds, dipping
Humidity	+/-1%	40°C,-95%RH, DC0.1W, 1000H
Load Life	+/-1%	70°C, 90minON, 30minOFF, 100H
Vibration	+/-1%	
Operating Temperature	-55 - +155 deg C	
Storage Temperature	-55 - +155 deg C	

Remarks:

Attenuators, RFA-50TS, RFA-300B, RFA-600B, RFA-85FD, RFA-85FC were discontinued, when request please call our factory.

VHF/UHF THROUGH-HOLE ATTENUATORS

RFA-50T, RFA-75T, RFA-300T, RFA-600T

RF Characteristics, Typical

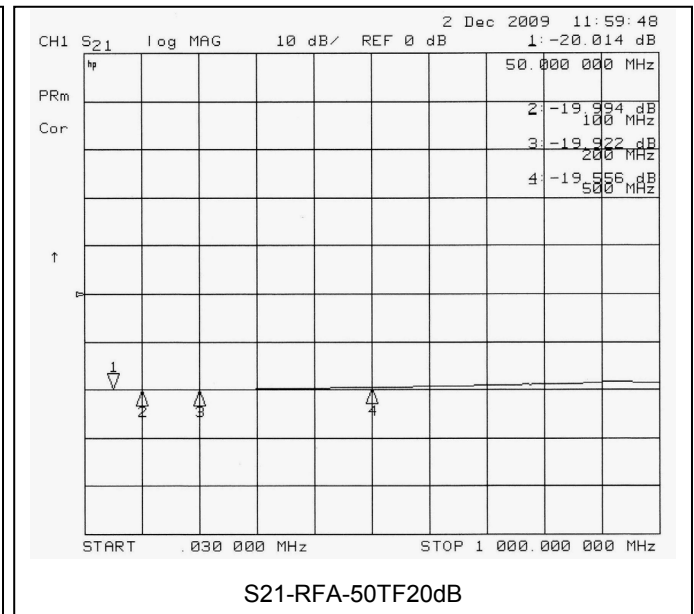
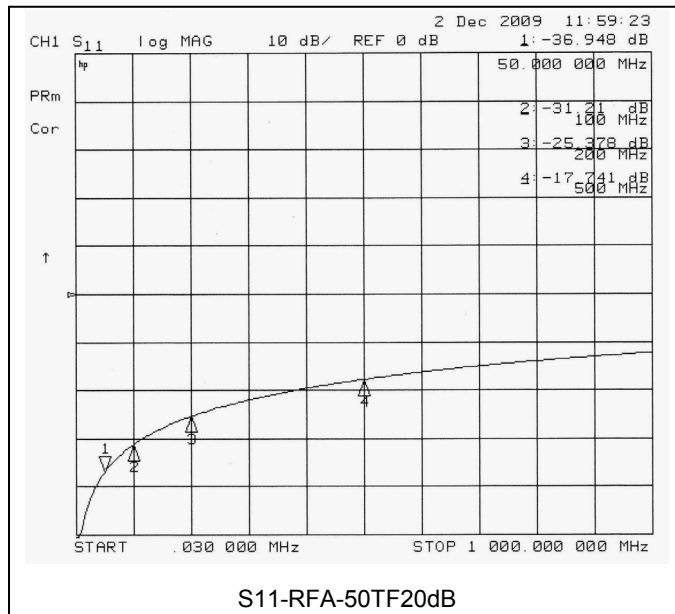
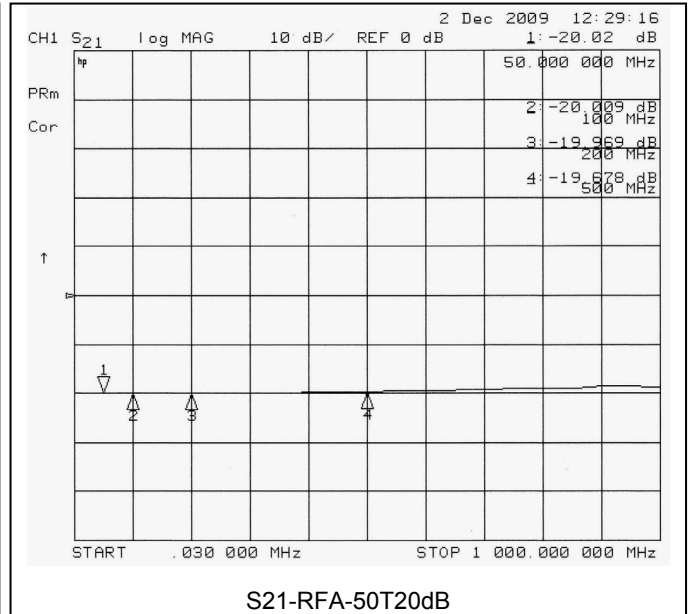
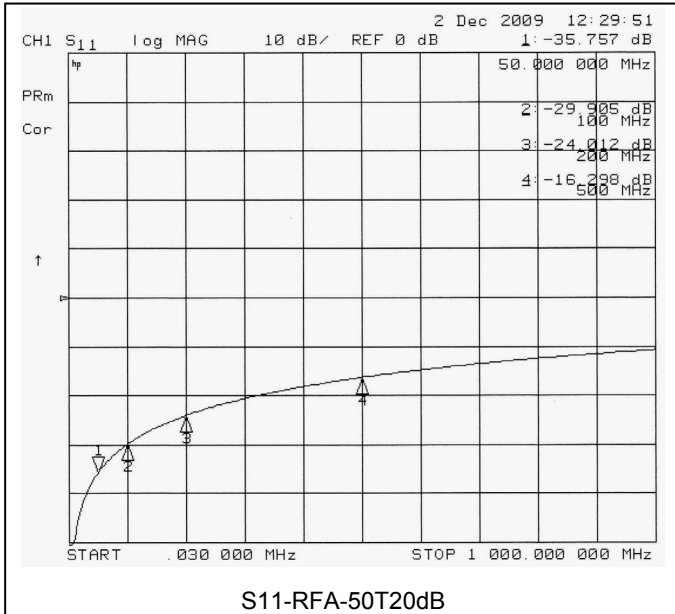

Note: Transformation between VSWR and S11:

$$VSWR = \frac{1 + |\Gamma|}{1 - |\Gamma|} \dots\dots |\Gamma| = 10^{\frac{S11}{20}}$$

$$|\Gamma| = \frac{VSWR - 1}{VSWR + 1} \dots\dots S11 = -(-20 \log |\Gamma|)$$

COAXIAL
RF POWER ATTENUATORS
RFA-54, RFA-55
RFA-85, RFA-67, RFA-37

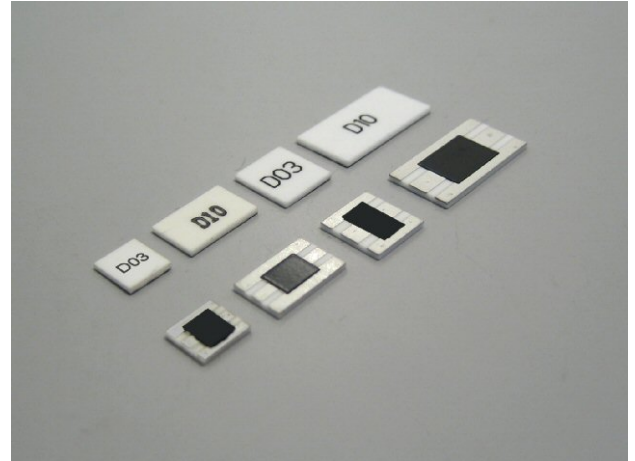

Features and Applications

RFA-54D, RFA-84D, RFA-67D, RFA-37D are used for balanced coaxial attenuators, and are durable with large rated power.

In RFA-55DD, face down configuration on co-planer line show better return loss characteristics.

RFA-68D, 1.5GHz-30W, by attached to the heat sink direct, small size power attenuator.

Long life and temperature stability of thin film technology realize better performance at a temperature range from -55°C to $+155^{\circ}\text{C}$.

Applications include gain control circuits, isolation circuits of power boost amplifiers at GHz, loss compensation of transmission line of data communication systems, detecting signal control of ATE-LSI test system-circuit board functional test systems, industrial measurement electronics, medical scientific electronics and miscellaneous communication systems.

Specifications and Performances

P/N	Type	Impedance	Attenuation (*1)	Frequency(*2)	Input Power(*3)
RFA-54DD	Coaxial	50 ohm	2, 3, 4, 5, 6, 7, 8, 9, 10, 20 dB	DC- 4GHz	0.25W
RFA-55DD	SMD	50 ohm	2, 3, 4, 5, 6, 7, 8, 9, 10, 20 dB	DC- 4GHz	0.25W
RFA-85DD	Coaxial	50 ohm	2, 3, 4, 5, 6, 7, 8, 9, 10, 20 dB	DC- 3GHz	0.50W
RFA-67DD	Coaxial	50 ohm	2, 3, 4, 5, 6, 7, 8, 9, 10, 20 dB	DC- 3GHz	1.00W
RFA-37DD	Coaxial	50 ohm	2, 3, 4, 5, 6, 7, 8, 9, 10, 20 dB	DC- 3GHz	1.00W
RFA-54DC	Coaxial	75 ohm	2, 3, 4, 5, 6, 7, 8, 9, 10, 20 dB	DC- 4GHz	0.25W
RFA-55DC	SMD	75 ohm	2, 3, 4, 5, 6, 7, 8, 9, 10, 20 dB	DC- 4GHz	0.25W
RFA-85DC	Coaxial	75 ohm	2, 3, 4, 5, 6, 7, 8, 9, 10, 20 dB	DC- 3GHz	0.50W
RFA-67DC	Coaxial	75 ohm	2, 3, 4, 5, 6, 7, 8, 9, 10, 20 dB	DC- 3GHz	1.00W
RFA-37DC	Coaxial	75 ohm	2, 3, 4, 5, 6, 7, 8, 9, 10, 20 dB	DC- 3GHz	1.00W

(*1) Attenuation tolerance at DC are 2,3,4,5,6db: $\pm 0.2\text{dB}$, 7,8,9,10dB: $\pm 0.3\text{dB}$, 20dB: $\pm 0.4\text{dB}$

(*2) Frequency range are typical at $S_{11} < 20\text{dB}$, please note it will be influenced by the structure.

(*3) Input power are typical values under condition of assembling into metal housing.

COAXIAL RF POWER ATTENUATORS

RFA-54, RFA-55, RFA-85, RFA-67, RFA-37

Ordering Information

Type	Configuration (*1)	Attenuation	Packaging	Note
RFA-67	DD	10dB	Z00	
RFA-54	DD(50ohm)	2dB	Z00	Bulk in PE box (Taping option)
RFA-55	DC(75ohm)	3dB	(Z01)	
RFA-85		4dB		
RFA-67		5dB		
RFA-37		6dB		
		7dB		
		8dB		
		9dB		
		10dB		
		20dB		
		16dB option		

(*1) DD shows balanced 50ohm and DC shows balanced 75ohm characteristic impedance.

Dimensions (mm)

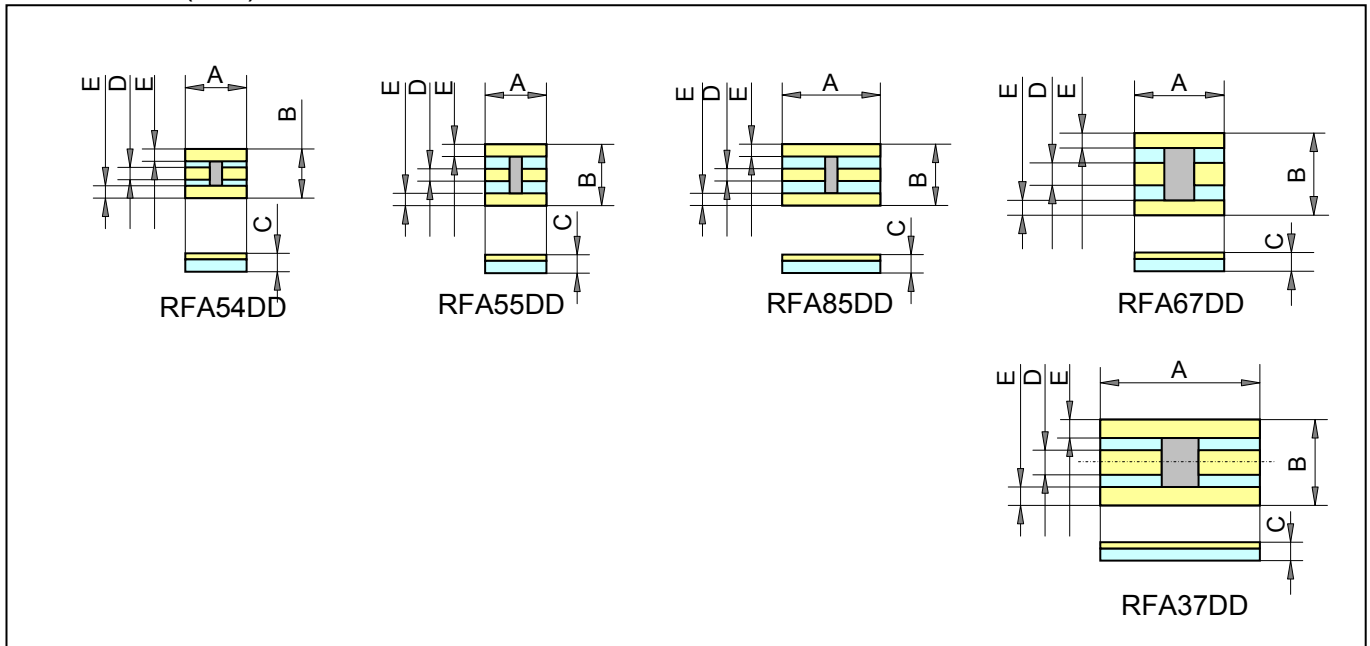

Type	A (mm)	B (mm)	C (mm)	D (mm)	E (mm)
RFA-54D	5.00	3.80	0.70	1.20	0.80
RFA-55D	5.00	4.50	0.70	1.20	1.00
RFA-85D	8.00	5.25	0.70	1.40	1.10
RFA-67D	6.00	7.00	0.70	2.00	1.40
RFA-37D	13.00	7.00	0.70	2.00	1.40

(*1) In case of 'DC', conductor width happen to change.

COAXIAL RF POWER ATTENUATORS RFA-54, RFA-55, RFA-85, RFA-67, RFA-37

Specifications

Items	Specifications	Test Conditions
Characteristic Impedance	50Ω / 75Ω	
Tolerance of Impedance	+/- 2% (G)	Input DC resistance in terminating output with resistor.
Tolerance of Attenuation	See Bottom of first page.	Output DC volt in terminating out put with resistor when stable 1V DC volt source connect to input.
TC of Impedance	+/- 50ppm/deg C	TC of input DC resistance in terminating output with resistor.
TC of Attenuation	+/- 50ppm/deg C	TC of output DC volt in terminating out put with resistor when stable 1V DC volt source connect to input.
Rating Temperature	-55-70 deg C	
Soldering Heat	+/- 1%	DC resistance, 350C, 3 seconds dipping.
Soldering capability	95% covered	
Humidity	+/- 1%	Input DC resistance change Under condition of 40C temp and 90-95%RH, rating power ON-90min, OFF-30min, 1000h
Load Life	+/- 1%	Input DC resistance change. Under condition of 70C temp, rating power ON-90min, OFF-30min, 1000h
Operating Temperature	-55deg C - +155deg C	At hot spot of resistive material
Storage Temperature	-55deg C - +155deg C	1000 hours in excluding solder-ability and conductor damage

Note: Above specifications are applied to RFA-54D, RFA-55D, RFA-85D, RFA-67D and RFA-37D.

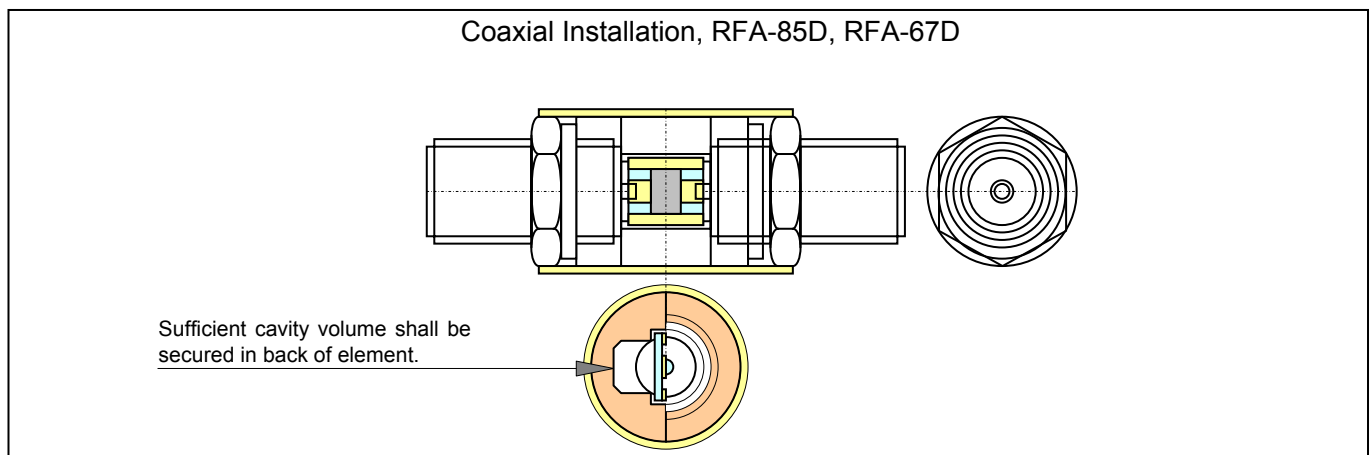
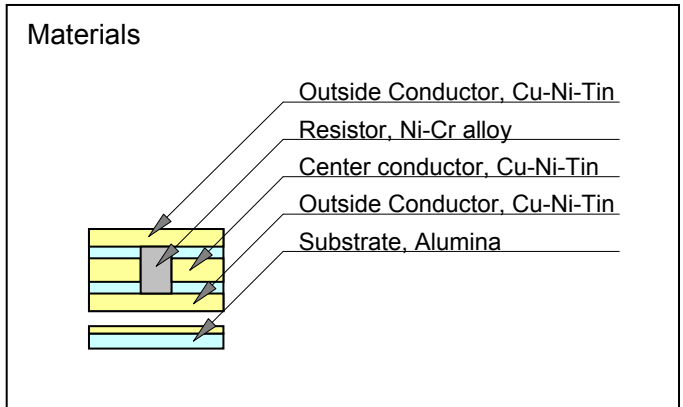
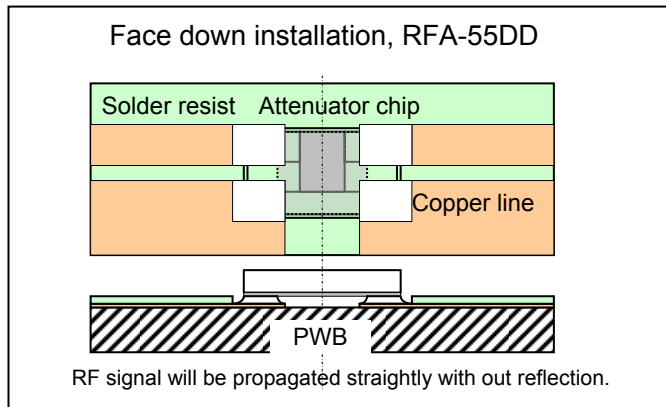

COAXIAL RF POWER ATTENUATORS
RFA-54, RFA-55, RFA-85, RFA-67, RFA-37

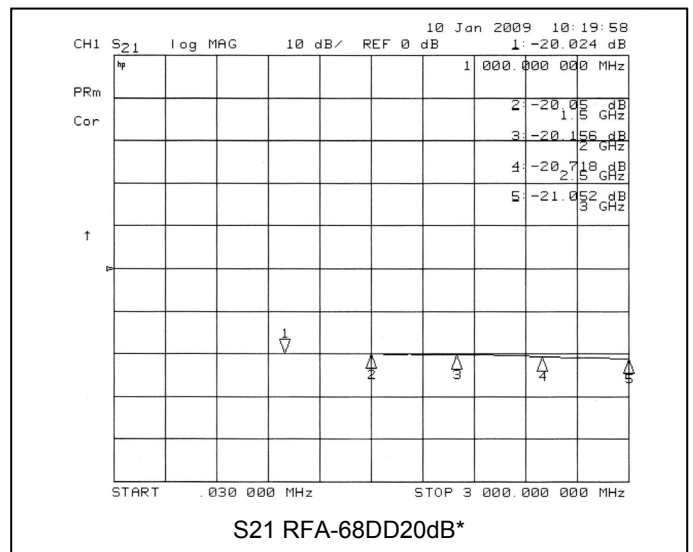
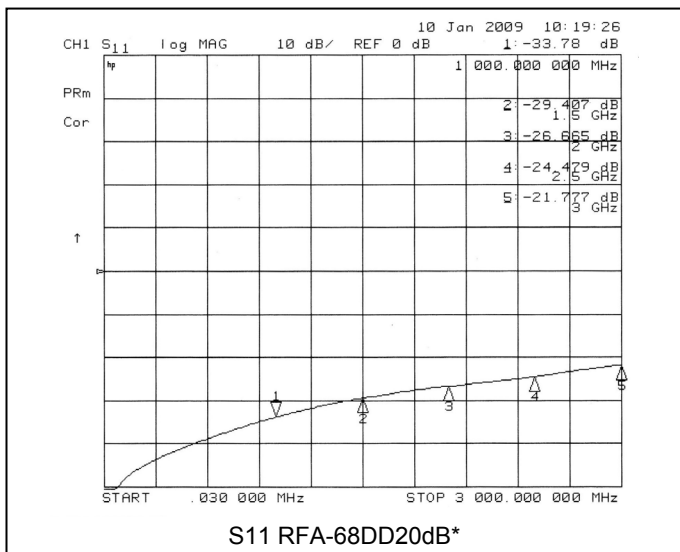
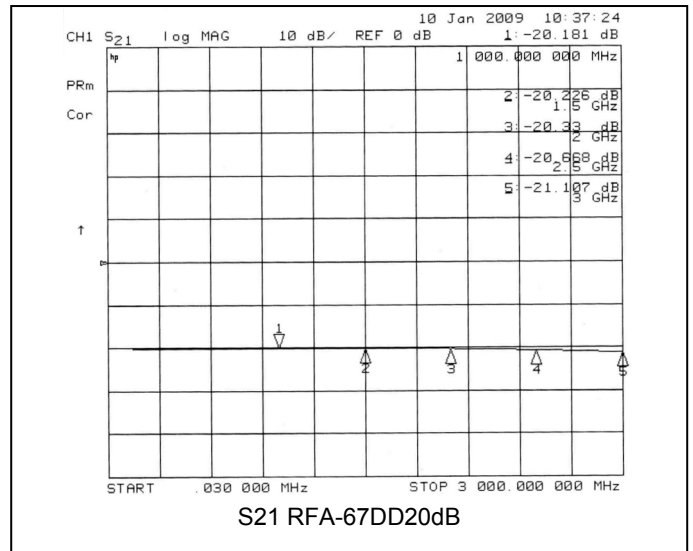
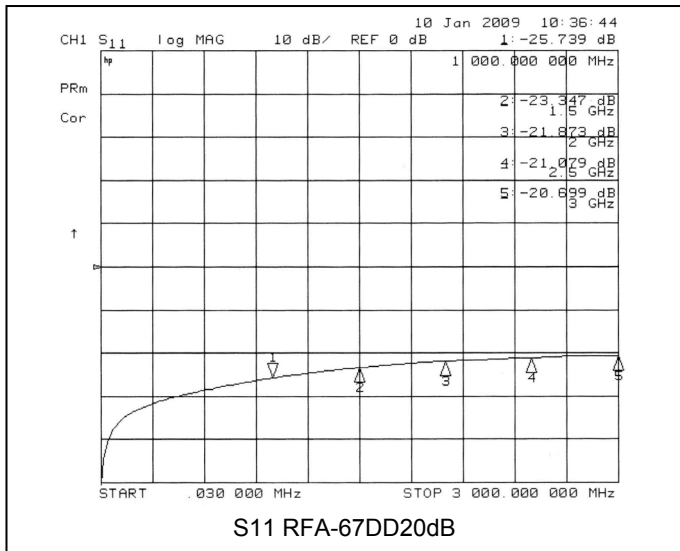
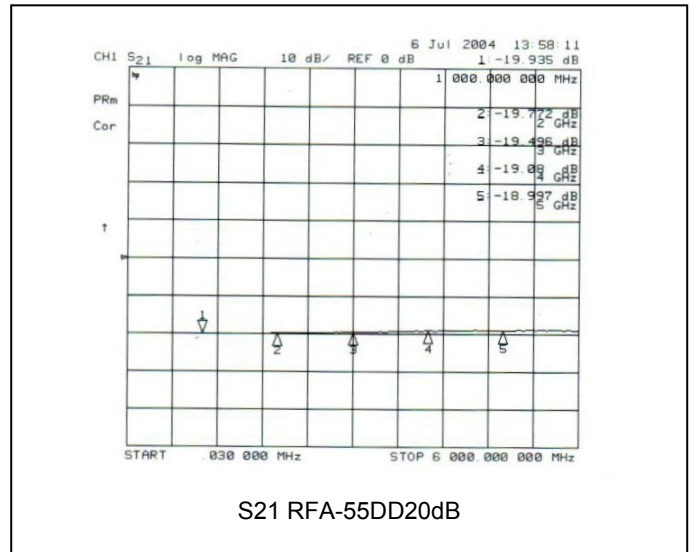
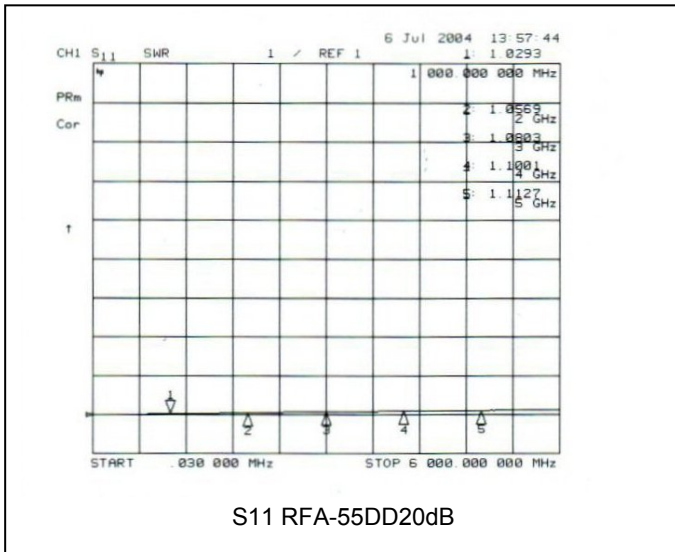

* Please call factory for a specification of RFA-68DD

COAXIAL MICROWAVE TERMINATION RFD33, RFD44, RFD54, RFD87

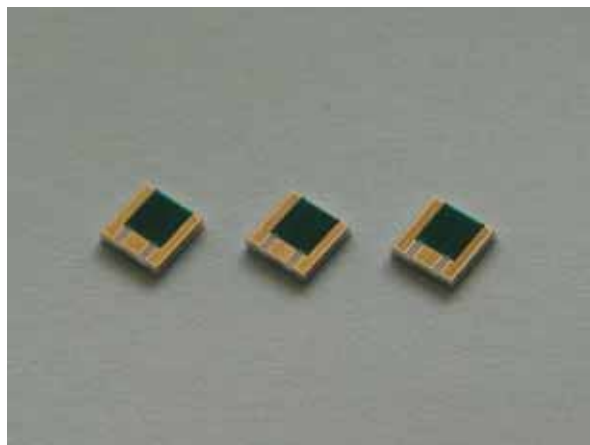

Feature and Applications

RF and microwave termination with 50ohm and 75 ohm characteristic impedance.

RFD is for termination of coaxial applications.

Ni-Cr thin film and alumina substrates realize long life and temperature stability.

Applications include RF amplifiers, radio transmitters, RF power sources, mobile communication systems and measurements.

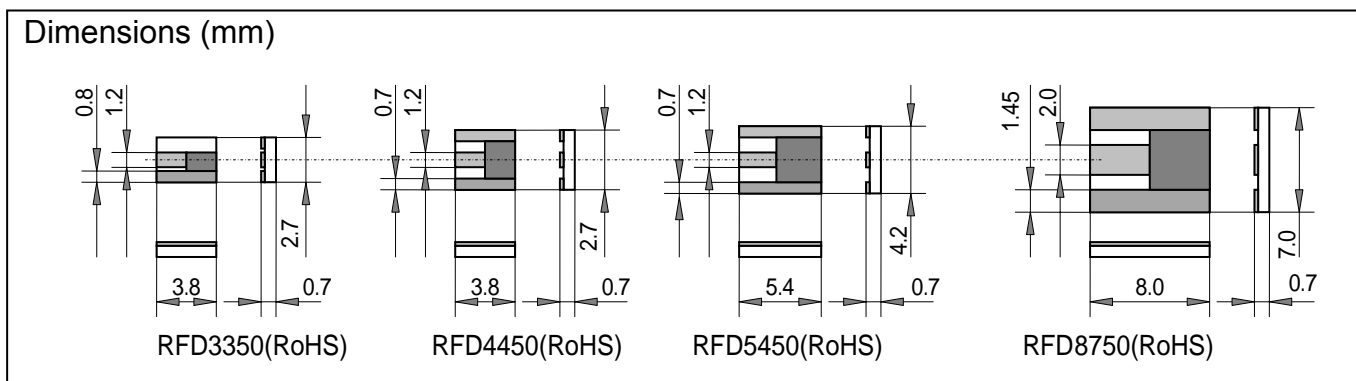

Specifications and Performances

Model	Type	Impedance	Rated Power (*2)	Frequency Range	Remarks
RFD3350	Coaxial, Unbalanced Chip	50Ω	0.25W	DC- 4GHz	RoHS
RFD4450	Coaxial, Balanced Chip	50Ω	0.25W	DC- 4GHz	RoHS
RFD4475	Coaxial, Balanced Chip	50Ω	0.50W	DC- 4GHz	RoHS
RFD5450	Coaxial, Balanced Chip	50Ω	0.50W	DC- 3GHz	RoHS
RFD5475	Coaxial, Balanced Chip	75Ω	0.50W	DC- 3GHz	RoHS
RFD8750	Coaxial, Balanced Chip	50Ω	1.00W	DC- 3GHz	RoHS
RFD8775	Coaxial, Balanced Chip	75Ω	1.00W	DC- 3GHz	RoHS

Ordering Information

P/N	Type	Resistance	Terminal	Remarks
RFD-4450 Z00	RFD-44	50 ohms	Z00	Bulk packaging
RFD-8750 Z00	RFD-44	50 ohms	Z00	Bulk packaging

(*1) The chip is designed as 50 Ohms coplanar transmission line. When you make termination in coaxial parts, please make both side slot in coaxial outer conductor and joint chip side conductor to case slot by soldering directly.

The chip element conducts heat through the conductor of both sides to metal casing at the atmosphere. The side and the back of a termination chip have not metal conductor film.

(*2) Rated power is decided depending on the size of the surface area of the metal casing which attaches an element. Please refer to the above shown rated electric power.

THERMAL CONVERTER ELEMENT JSTC04

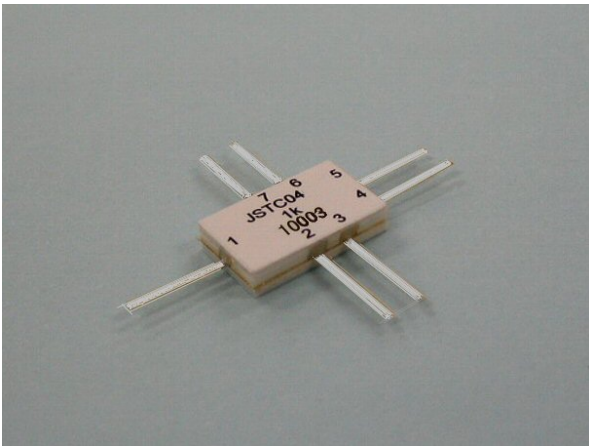

Features and Applications

The JSTC04 is a high-frequency multi-junction thermal converter device for high-precision AC-DC transfer standards. Using NIKKOHM's unique thin-film thermopile technology, this device realizes sensitivity of 10^{-6} to 10^{-7} for comparing rms power between ac and dc input voltages.

The JSTC04 thermal converter is designed to minimize effects from stray inductances and capacitances in the input circuit. The frequency characteristic of the AC-DC transfer difference is self-calculable, and has been evaluated to be better than 0.001% in the frequency range between 10kHz to 100 kHz, and better than 0.01% up to 1 MHz.

All the JSTC04 devices are identified by serial production numbers, and are individually inspected and guaranteed for the specifications. The inspection data include input resistance, output resistance, sensitivity (output voltage), and reversal error.

The JSTC04 thermal converter has been developed through the collaboration with AIST (National Institute of Advanced Industrial Science and Technology, Japan).

Dimensions, Pin Configuration and Connection

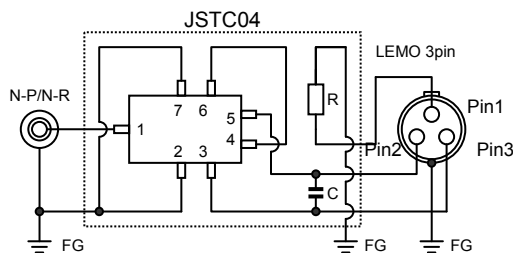
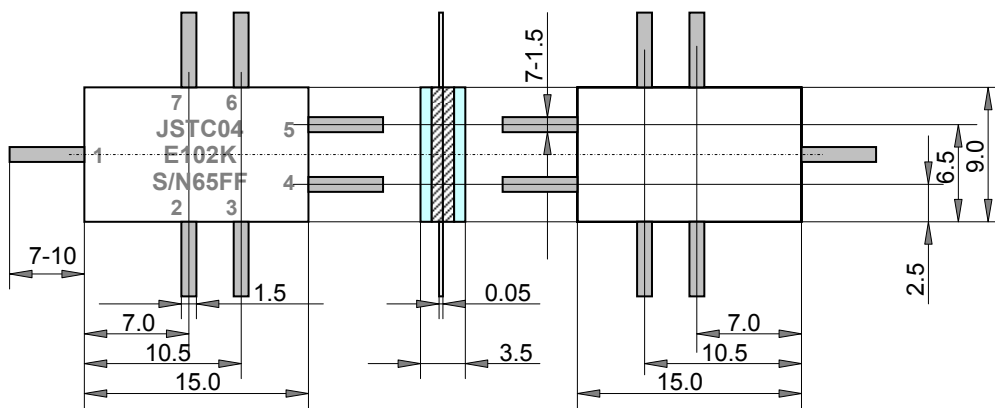

pin	Descriptions
1	Input Hi
2	Input Lo., internal connect to 7
3	DC output A +
4	DC output A -
5	DC output B -
6	DC output B +
7	Input Lo., internal connect to 2

THERMAL CONVERTER ELEMENT

JSTC04

Ordering Information

Model	TCR, input resistance	Input resistance (*)	Tolerance, Input resistance	Additional Code
JSTC04	E	500 Ohm	K	Z00
JSTC04	E (+/-25ppm/K)(*)	100 Ohm	K(+/-10%)	Z00 (RoHS)
		200 Ohm		
		500 Ohm		
		1k Ohm		
		2k Ohm		

(*) Other input resistances, TCs, and tolerances are available on request.

Specifications and Performances

	JSTC04	Conditions
INPUT		
Rated Power	0.1 W	
Max Applied Power	0.5 W	
Resistance	100, 200, 500, 1K, 2K Ohms	
TCR	+/-25ppm/K (E)	
Tolerance	+/-10% (K)	
Frequency Range	DC,10kHz-1MHz	
OUTPUT		
Rating output voltage	More than 60mV	
Output resistance	Less than 400 Ohm	
TC of Output resistance	+/- 300ppm/K	
INPUT/OUTPUT		
Sensitivity	More than 0.6 V/W	
TC of Sensitivity	-0.001mV/mW/K	Typical
Response Time	2.5 +/-0.6 seconds	63% response
Reversal Error	Less than 100ppm	Typical
AC-DC Difference, 10k-100kHz	Less than 10ppm	Typical
AC-DC Difference, 100K-1MHz	Less than 100ppm	Typical
ENVIRONMENTAL		
Operating Temp.	25 +/- 5 degree C	
Storage Temp.	-20 to 80 degree C	

Recommended Foots patterns

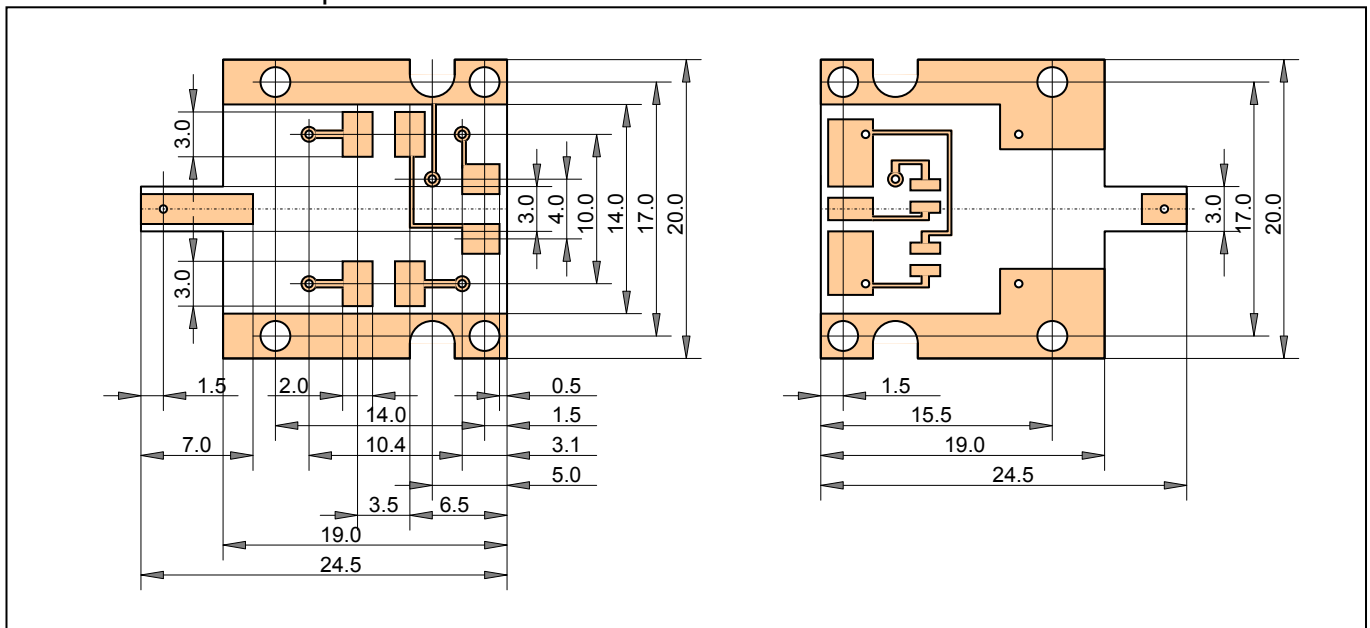

20100520

THERMAL CONVERTER ELEMENT JSTC05

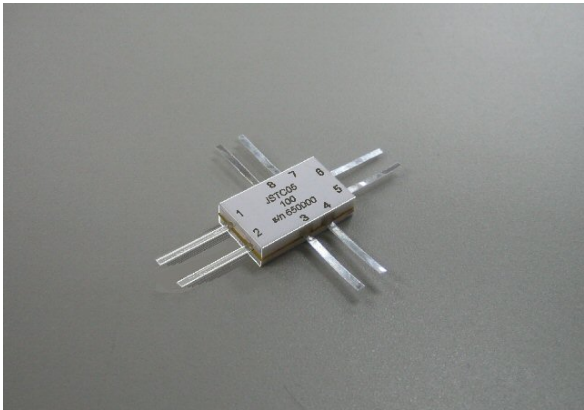

Features and Applications

The JSTC05 is a low-frequency multi-junction thermal converter device for high-precision AC-DC transfer standards. Using NIKKOHM's unique thin-film thermopile technology, this device realizes sensitivity of 10⁻⁶ to 10⁻⁷ for comparing rms power between ac and dc input voltages.

The JSTC05 thermal converter has special dual-heater structure to adopt the 90-degree-addition method for the evaluation of low-frequency effect due to insufficient thermal averaging. By increasing thermal mass and reducing temperature coefficient of the input circuit, frequency characteristic better than 0.001% has been realized in the frequency range between 10 Hz to 10 kHz.

All the JSTC05 devices are identified by serial production numbers, and are individually inspected and guaranteed for the specifications. The inspection data include input resistance, output resistance, sensitivity (output voltage), and reversal error.

The JSTC05 thermal converter has been developed through the collaboration with AIST (National Institute of Advanced Industrial Science and Technology, Japan).

Dimensions, Pin Configuration and Connection

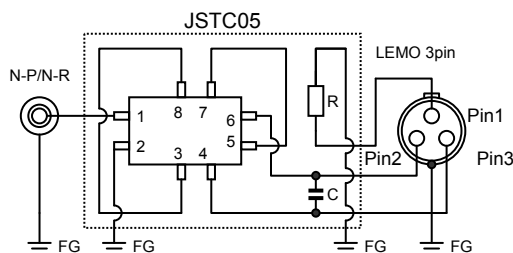
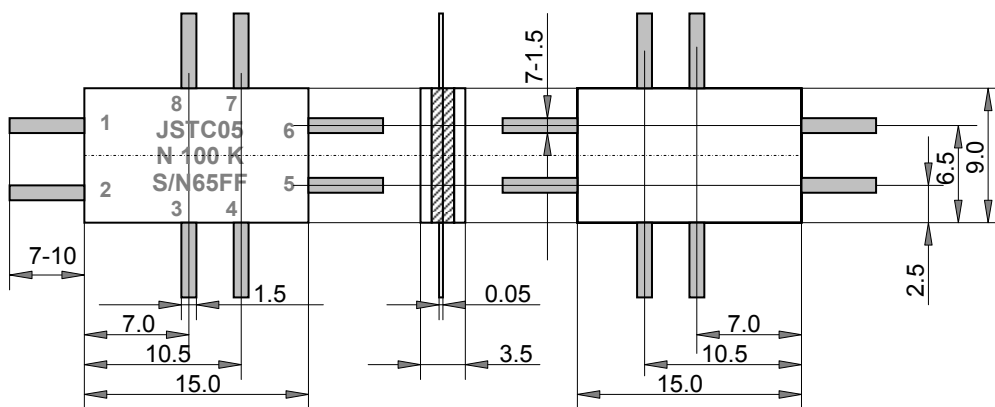

pin	Descriptions
1	Input A + to N connector.
2	Input B + to FG
3	Input B - to pin 8
4	DC output A +
5	DC output A -
6	DC output B -
7	DC output B+-
8	Input A -

THERMAL CONVERTER ELEMENT

JSTC05

Ordering Information

Model	TCR, input resistance	Input resistance (*)	Tolerance, Input resistance	Additional Code
JSTC05	N	100 Ohm	K	Z00
JSTC05	N (+/-10ppm/K) (*)	100 Ohm (x2)	K(+/-10%)(*)	Z00 (RoHS)

(*) Other input resistances, TCs, and tolerances are available on request.

Specifications and Performances

	JSTC05	Conditions
INPUT		
Rated Power	0.1 W	Total
Max Applied Power	0.5 W	Total
Resistance	100 Ohm (x2)	Another resistance available, please call factory
TCR	+/-10ppm/K (N)	
Tolerance	+/-10% (K)	
Resistance Matching	+/-1%	
Frequency Range	DC, 5Hz-10kHz	
OUTPUT		
Rating output voltage	More than 60mV	
Output resistance	Less than 400 Ohm	
TC of Output resistance	+/- 300ppm/K	
INPUT/OUTPUT		
Sensitivity	More than 0.6 V/W	
TC of Sensitivity	-0.001mV/mW/K	Typical
Response Time	6.0 +/-1.0 seconds	63% response
Reversal Error	Less than 100ppm	Typical
AC-DC Difference, 10Hz-10kHz	Less than 10ppm	Typical
ENVIRONMENTAL		
Operating Temp.	25 +/- 5 degree C	
Storage Temp.	-20 to 80 degree C	

Recommended Foots patterns (mm)

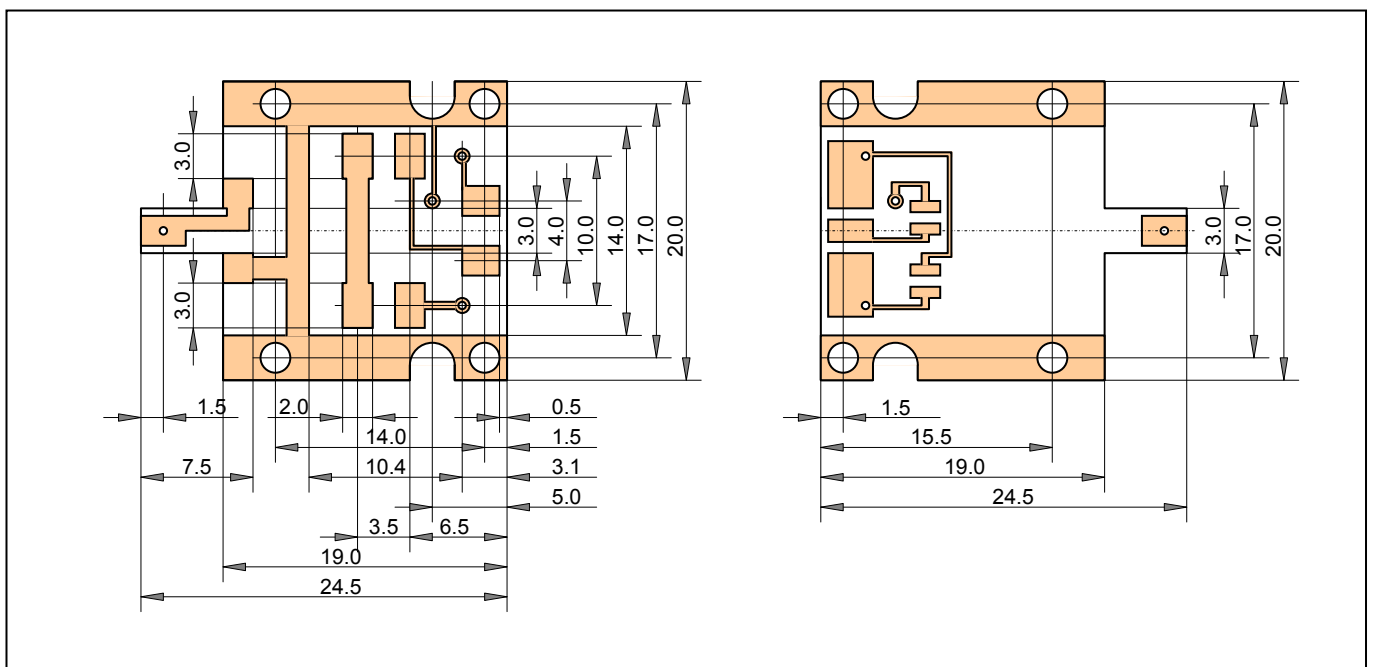

20100520

THERMAL CONVERTER ELEMENT JSTC06

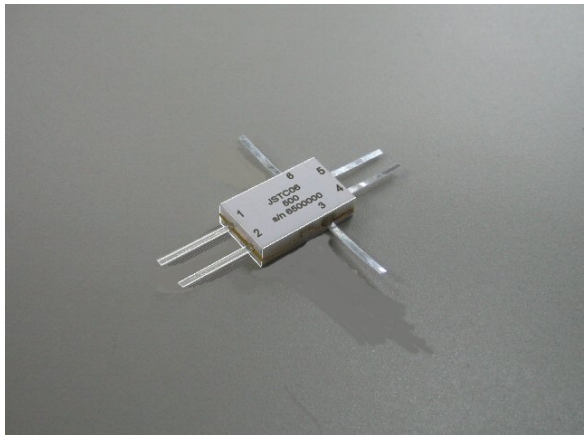

Features and Applications

The JSTC06 is a general-purpose multi-junction thermal converter device for high-precision AC-DC transfer standards. Using NIKKOHM's unique thin-film thermopile technology, this device realizes sensitivity of 10^{-6} to 10^{-7} for comparing rms power between ac and dc input voltages.

The JSTC06 thermal converter is designed for the operation at wide frequency range between 10Hz to 1MHz. By the use of U-shape heater pattern, the reversal error of the JSTC06 is reduced to be smaller than 0.001%. AC-DC transfer difference of the JSTC06 is better than 0.001% in the frequency range between 10 Hz to 100 kHz, and better than 0.01% up to 1 MHz.

All the JSTC06 devices are identified by serial production numbers, and are individually inspected and guaranteed for the specifications. The inspection data include input resistance, output resistance, sensitivity (output voltage), and reversal error.

The JSTC06 thermal converter has been developed through the collaboration with AIST (National Institute of Advanced Industrial Science and Technology, Japan).

Dimensions, Pin Configuration and Connection

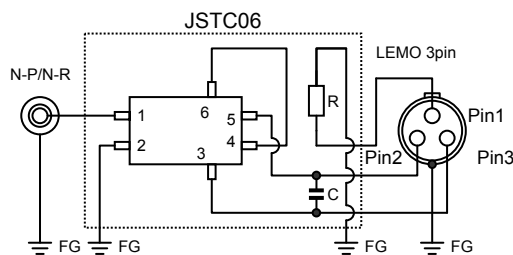
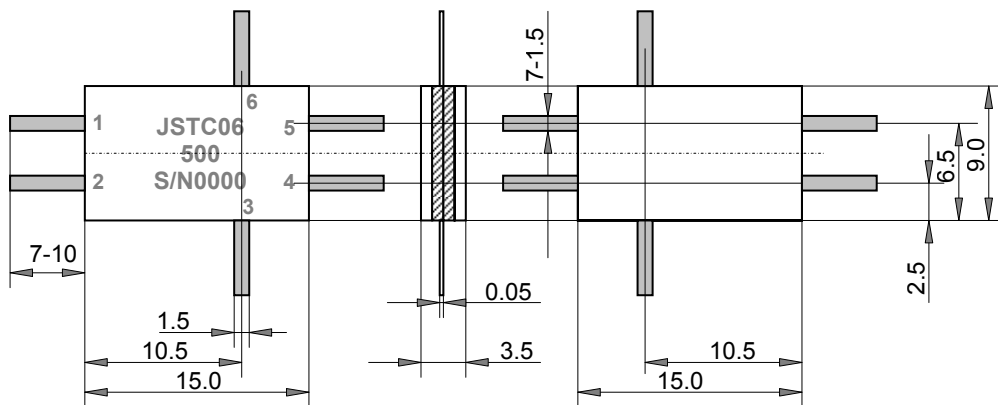

pin	Descriptions
1	Input + to N connector
2	Input - to FG
3	DC output A +
4	DC output A -
5	DC output B -
6	DC output B +

THERMAL CONVERTER ELEMENT

JSTC06

Ordering Information

Model	TCR, input resistance	Input resistance (*)	Tolerance, Input resistance	Additional Code
JSTC06	E	500 Ohm	K	Z00
JSTC06	E (+/-25ppm/K) (*)	100 Ohm	K(+/-10%)	Z00 (RoHS)
		200 Ohm		
		500 Ohm		
		1k Ohm		
		2k Ohm		

(*) Other input resistances, TCs, and tolerances are available on request.

Specifications and Performances

	JSTC06	Conditions
INPUT		
Rated Power	0.1 W	
Max Applied Power	0.5 W	
Resistance	100, 200, 500, 1K, 2K Ohms	
TCR	+/-25ppm/K (E)	
Tolerance	+/-10% (K)	
Frequency Range	DC,10Hz-1MHz	
OUTPUT		
Rating output voltage	More than 60mV	
Output resistance	Less than 400 Ohm	
TC of Output resistance	+/- 300ppm/K	
INPUT/OUTPUT		
Sensitivity	More than 0.6 V/W	
TC of Sensitivity	-0.001mV/mW/K	Typical
Response Time	2.5 +/-0.6 seconds	63% response
Reversal Error	Less than 10ppm	Typical
AC-DC Difference, 10Hz-100kHz	Less than 10ppm	Typical
AC-DC Difference, 100K-1MHz	Less than 100ppm	Typical
ENVIRONMENTAL		
Operating Temp.	25 +/- 5 degree C	
Storage Temp.	-20 to 80 degree C	

Recommended Foots patterns

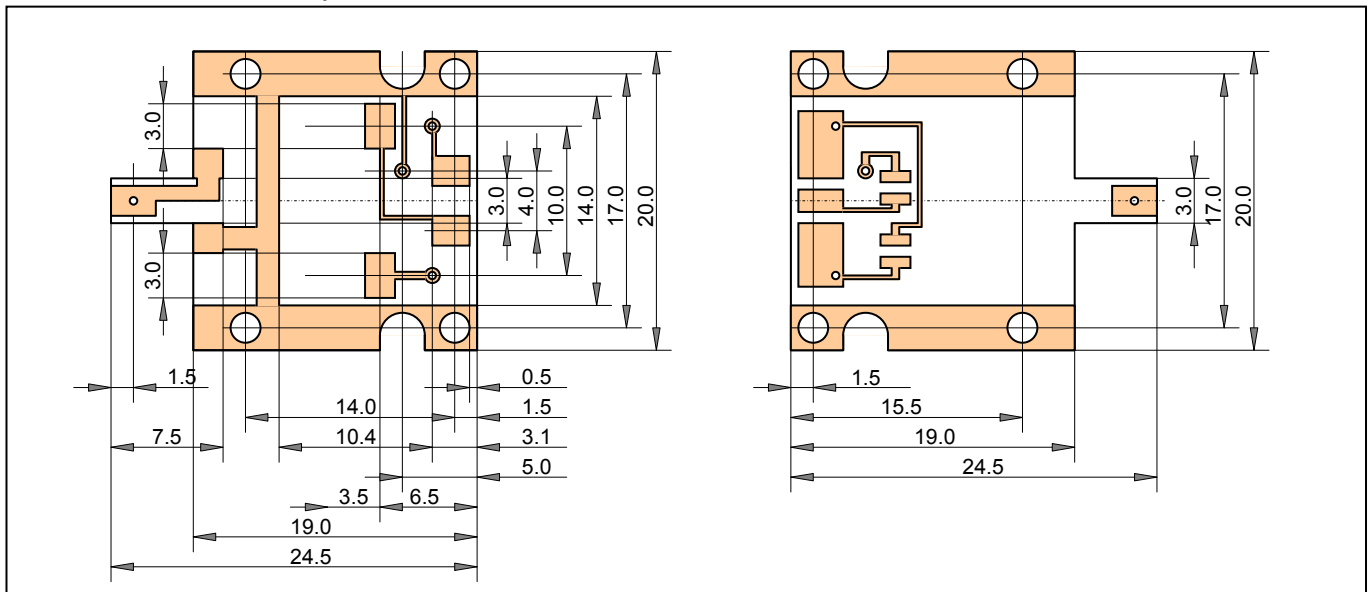

20100520

THERMAL VOLTAGE CONVERTER
 TVC04A, TVC05B
 TVC06A, TVC06B



Features and Applications

The Thermal Voltage Converters TVC04/05/06(A/B) are fully assembled version of the JSTC04/05/06 series thermal converter elements, and may readily be used as the AC-DC transfer standard with input and output connectors. The TVC0xA thermal voltage converter employs the virtual-TEE configuration ("internal" or "built-in" TEE). Combined with the JSTC04 element, precise evaluation of frequency characteristic of the ac-dc transfer difference is possible at 10⁻⁶ level up to 1MHz. While the TVC0xB has similar configuration as the TVC0xA, except that the second input connector for the virtual-TEE configuration is not installed. The TVC0xA is best suited for the use with JSTC05 or JSTC06 elements.

All the HF-TVC modules are identified by serial production numbers, and are individually inspected and guaranteed for the specifications. The inspection data include input resistance, output resistance, sensitivity (output voltage), reversal error. The ac-dc transfer difference data with respect to the NIKKOHM's reference standard will also be attached to the TVC.

The HF-TVC has been developed through the collaboration with AIST (National Institute of Advanced Industrial Science and Technology, Japan).

Dimensions

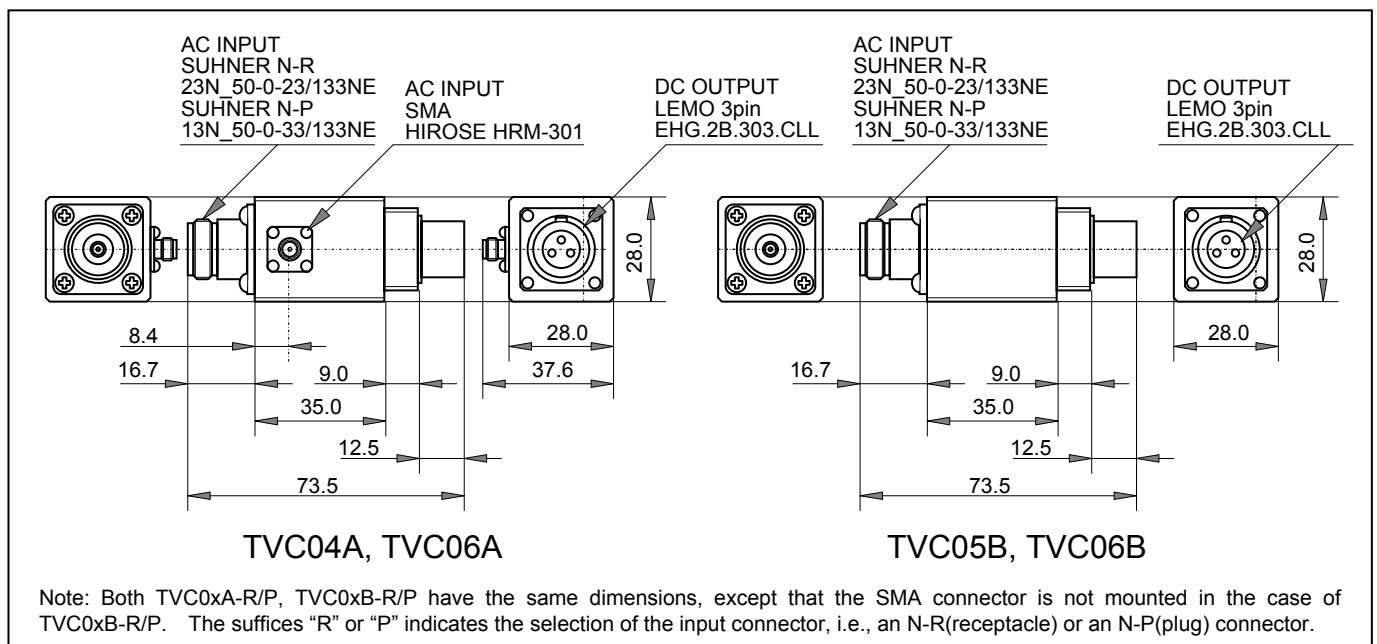

MEASUREMENTS – NIKKOHM

THERMAL VOLTAGE CONVERTER TVC04A, TVC05B, TVC06A, TVC06B

Ordering Information

Type	Input Connector	Input resistance TCR	Input resistance	Input resistance Tolerance	Remarks
TVC04A	R	E	500 Ohm	K	---
TVC04A	R (Receptacle)	N (+/-10ppm/deg C)	100 Ohm	K (+/-10%)	---
TVC05B	P (Plug)	E(+/-25ppm/deg C)	200 Ohm		
TVC06A			500 Ohm		
TVC06B			1k Ohm		
			2k Ohm		

*N applies to TVC05

Specifications and Performances (for type TVC04/05 refer to JSTC04/05 datasheet)

	TVC04A	TVC05B	TVC06A, TVC06B	Conditions
INPUT				
Rated Power	0.1 W	0.1 W	0.1 W	
Max Applied Power	0.5 W	0.5 W	0.5 W	
Resistance (Ohm)	100, 200, 500, 1k, 2k	100 Ohms	100, 200, 500, 1k, 2k	.
TCR	+/-25ppm/K (E)	+/-10ppm/K (N)	+/-25ppm/K (E)	
Tolerance	+/-10% (K)	+/-10% (K)	+/-10% (K)	
Frequency Range	DC, 10kHz-1MHz	DC, 5Hz-10kHz	DC, 10Hz-1MHz	
OUTPUT				
Rating output voltage	More than 60mV	More than 60mV	More than 60mV	
Output resistance	Less than 400Ohm	Less than 400Ohm	Less than 400Ohm	
TC of Output resistance	+/- 300ppm/K	+/- 300ppm/K	+/- 300ppm/K	
INPUT/OUTPUT				
Sensitivity	More than 0.6 V/W	More than 0.6 V/W	More than 0.6 V/W	
TC of Sensitivity	-0.001mV/mW/K	-0.001mV/mW/K	-0.001mV/mW/K	Typical
Response Time	2.5 +/-0.6 seconds	6.0 +/-1.0 seconds	2.5 +/-0.6 seconds	63% response
Reversal Error	Less than 100ppm	Less than 100ppm	Less than 10ppm	Typical
AC-DC Difference, 10Hz-100kHz	*Less than 10ppm	**Less than 10ppm	Less than 10ppm	Typical
AC-DC Difference, 100K-1MHz	Less than 100ppm		Less than 100ppm	Typical
Environmental				
Operating Temp.	25 +/- 5 degree C	25 +/- 5 degree C	25 +/- 5 degree C	
Storage Temp.	-20 to 80 degree C	-20 to 80 degree C	-20 to 60 degree C	
Mechanical				
Weight (Net)	275 gram	275 gram	275 gram	

(*) 10kHz-100kHz, (**) 10Hz-10kHz

Internal schematic

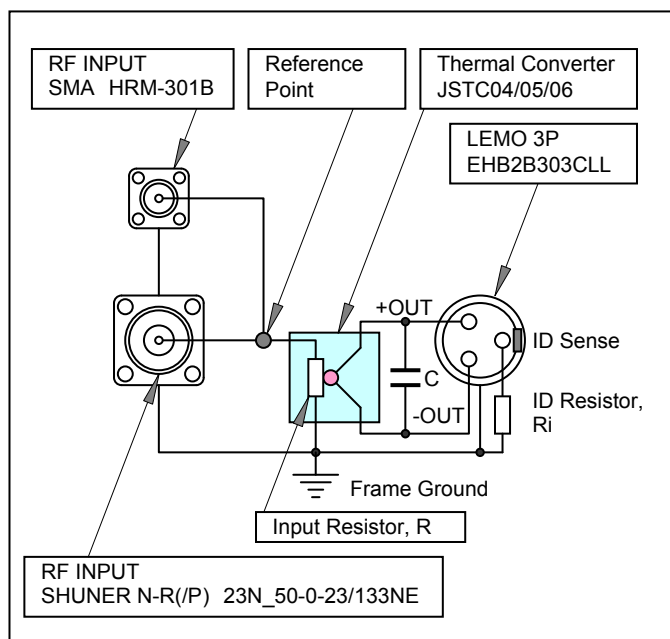

Values of the ID Resistor (Ri)

Input Resistance, R	ID Sense Resistors, Ri
50 Ohm	50 - (56) - 82 Ohms
100 Ohm	100 - (120) - 180 Ohms
200 Ohm	200 - (220) - 470 Ohms
500 Ohm	500 - (560) - 820 Ohms
1K Ohm	1k - (1.2K) - 1.8k Ohms
2K Ohm	2k - (2.2K) - 4.7k Ohms

Note: The values in parenthesis are nominal values. Other values are available on request..

Note: Output Capacitance

The shunting capacitance between the output pins is 10 nF. Other values are available on request.

20110701

MEASUREMENT – NIKKOHM

AC-DC THERMAL VOLTAGE CONVERTER CASE KIT TVCC

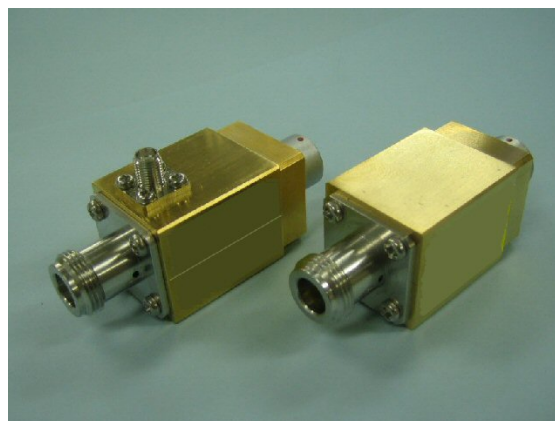

Features and Applications

A kit of containing metal chassis, N-connectors (P or R), SMA connector, LEMO-3 pins connector, circuit boards and screws for assembling TVC04, TVC05 or TVC06.

The Kit does not contain JSTC, wires and name plate.

Material of metal case is Au plated brass.

Ordering Information and Parts

Ordering P/N	TVCC04AR	TVCC05BR	TVCC06AR	TVCC06BR
Input Connector, N	SUHNER N-R	SUHNER N-R	SUHNER N-R	SUHNER N-R
Input Connector, SMA	SMA HIROSE HRM-300-60S	---	SMA HIROSE HRM-300-60S	---
Output Connector	LEMO 3pin	LEMO 3pin	LEMO 3pin	LEMO 3pin
Circuit Board	PCB04	PCB05	PCB06	PCB06
Chassis	Chassis A	Chassis B	Chassis A	Chassis B
Screws, M2.6-6mm	4	---	4	---
Screws, M3-16mm	4	4	4	4
Screws, M3-8mm	4	4	4	4
Screws, M3-12mm	4	4	4	4
Screws, M2-4mm	4	4	4	4
Wires	---	---	---	---
T-C Element	---	---	---	---
Capacitor	10pF	10pF	10pF	10pF
Resistor	[1608]-560Ohm-J	[1608]-560Ohm-J	[1608]-560Ohm-J	[1608]-560Ohm-J
Remarks				

Ordering P/N	TVCC04AP	TVCC05BP	TVCC06AP	TVCC06BP
Input Connector, N	SUHNER N-P	SUHNER N-P	SUHNER N-P	SUHNER N-P
Input Connector, SMA	SMA HIROSE HRM-300-60S	---	SMA HIROSE HRM-300-60S	---
Output Connector	LEMO 3pin	LEMO 3pin	LEMO 3pin	LEMO 3pin
Circuit Board	PCB04	PCB05	PCB06	PCB06
Chassis	Chassis A	Chassis B	Chassis A	Chassis B
Screws, M2.6-6mm	4	---	4	---
Screws, M3-16mm	4	4	4	4
Screws, M3-8mm	4	4	4	4
Screws, M3-12mm	4	4	4	4
Screws, M2-4mm	4	4	4	4
Wires	---	---	---	---
T-C Element	---	---	---	---
Capacitor	10pF	10pF	10pF	10pF
Resistor	[1608]-560Ohm-J	[1608]-560Ohm-J	[1608]-560Ohm-J	[1608]-560Ohm-J
Remarks				

Note: "----" shows not included.

AC-DC THERMAL VOLTAGE CONVERTER CASE KIT

TVCC

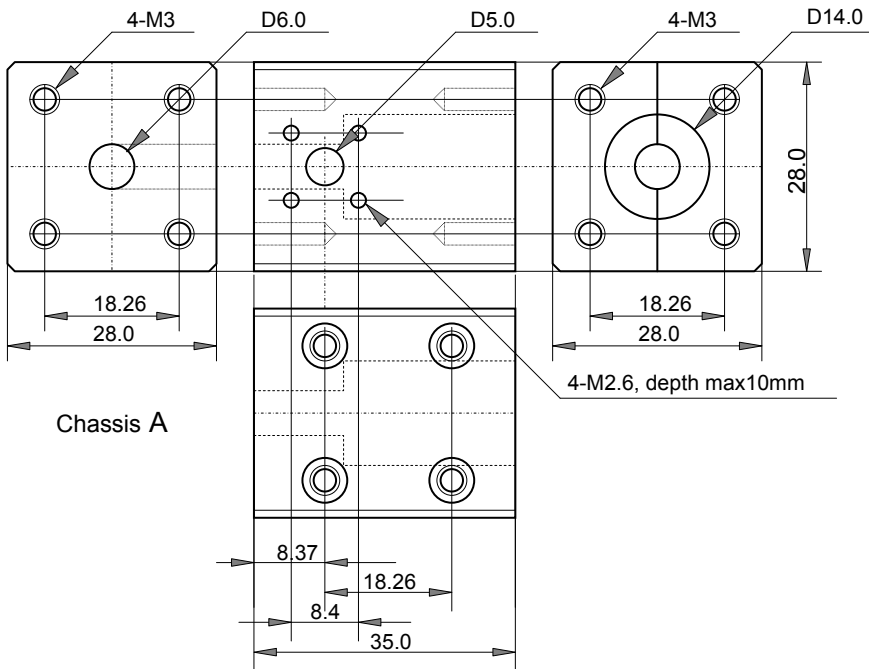

Chassis A

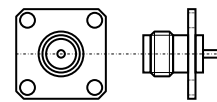
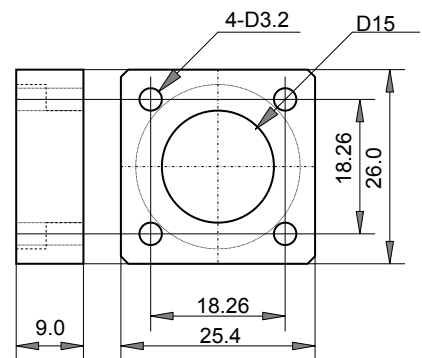

AC INPUT
SMA HIROSE HRM-300-60S

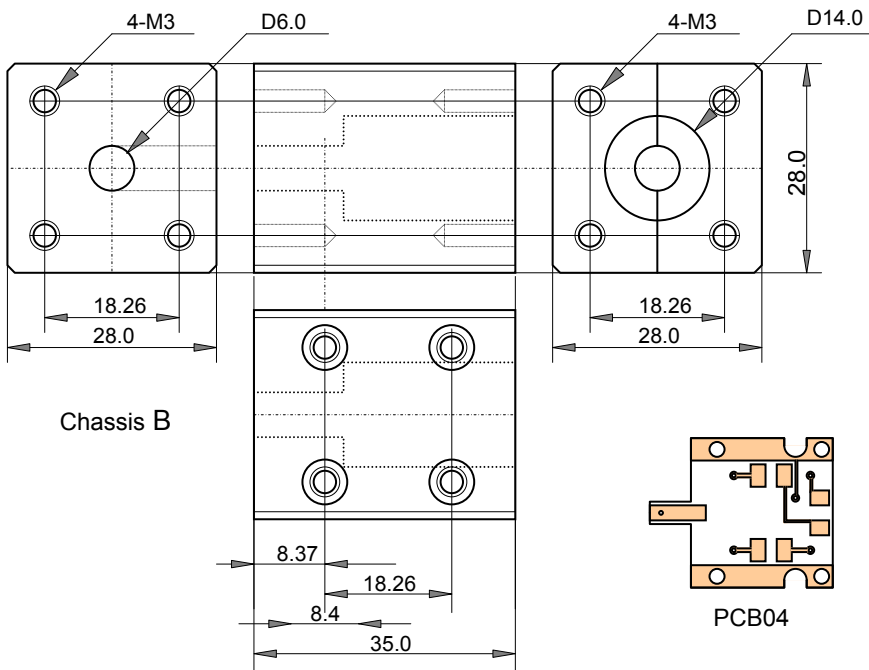

Chassis B

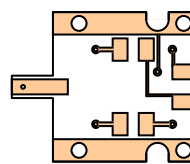

PCB04

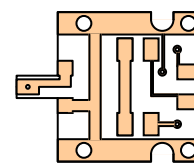

PCB05

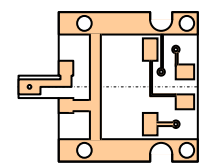

PCB06

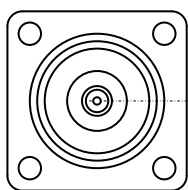

AC INPUT
SUHNER N-R_23N_50-0-23/133NE

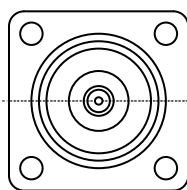
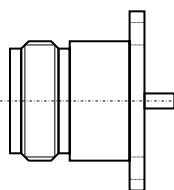

AC INPUT
SUHNER N-P_13N_50-0-33/133NE

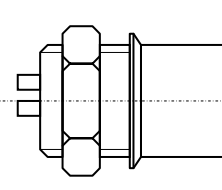
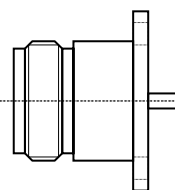

DC OUTPUT
LEMO 3pin EHG.2B.303.CLL

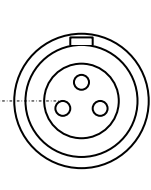

RMS-DC THERMAL CONVERTER LP73F



Features and Applications

True RMS-DC converter.

LP73F converts AC/RF input voltage to DC output volt.

Output voltage shows rms power of modulated wave form, waveform with distortion and noise waveform. Wide frequency range operation and long-life operation are available.

For RF power measurements, RMS-DC conversion, thermal converter applications.

Dimensions (mm), Pin configuration and Materials

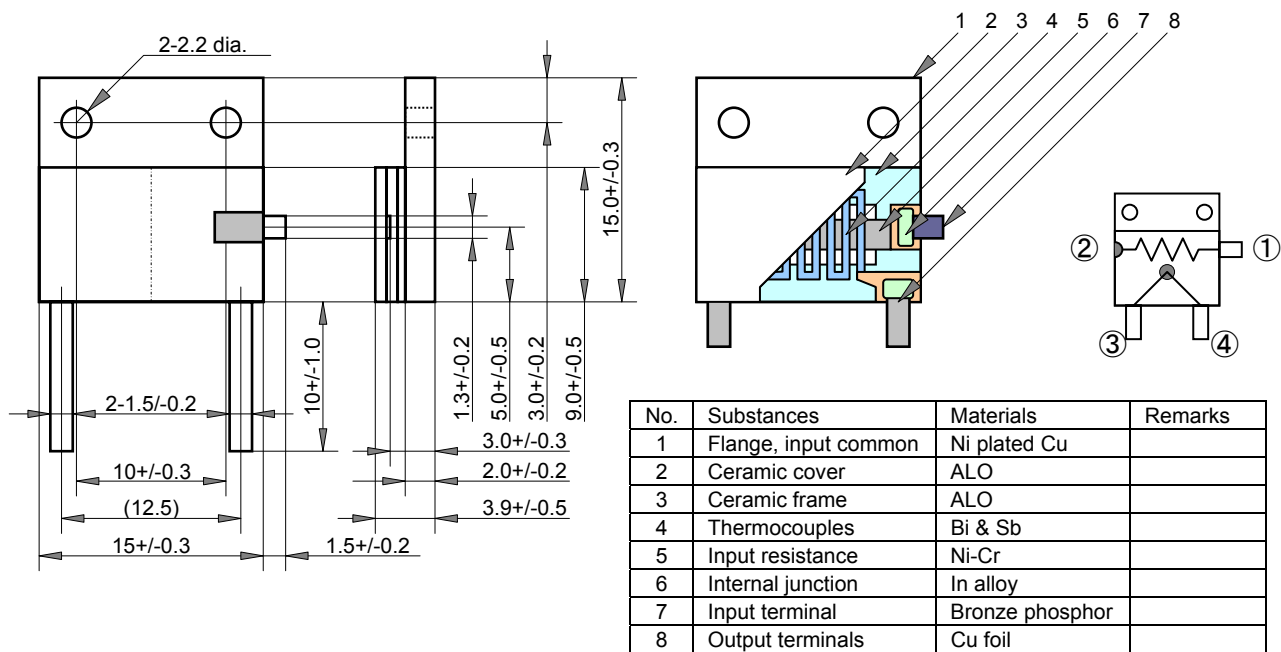

Ordering Information

Model	TCR	Input Resistance	Tolerance	Additional	Remarks
LP73F	A	50ohm	K	Z00	
LP73F	A(100ppm/C)	50ohm 75ohm	K(10%)	Z00	

RMS-DC CONVERTER

LP73F

Specifications and Performances

INPUT		
Rating Power	10mW	
Max Applied Power	30mW	For 10 seconds
Resistance	50ohm or 75ohm +/-10%	
TCR	+/-100ppm/deg C	
Tolerance		
Frequency Range	DC-120MHz	
OUTPUT		
Sensitivity	13mV+/-2mV/10mW	
TC of Sensitivity	(-0.2% +/- 0.1%)/deg C	
Linearity	< 98%	At output voltage 1-13mV
Internal Resistance	2kohm+/-1kohm	
Response Time	<1 seconds	63% response
Terminal strength	> 9.8N	Pull
Insulation Resistance	> 20Mohm	Base plate to terminals
Operating Temp.	-10 – 60 deg C	
Storage Temp.	-20 – 80 deg C	
Weight	4.3g	

Note

Recommended soldering temperature is 220-230 deg C soldering iron with heat-insulating clip.

Mechanical shock in transportation and handling shall be kept away.

Electric static discharge shall be escaped.

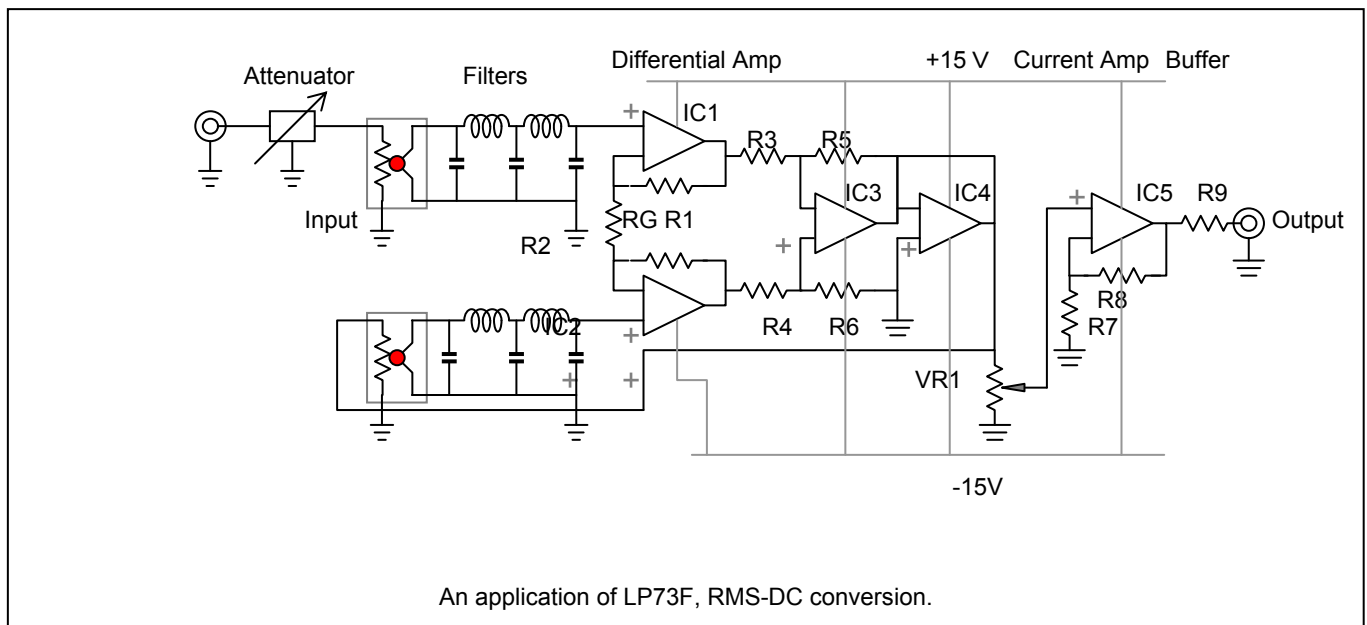

RMS-DC CONVERTER
LP-34B, LP34TW



Features and Applications

True RMS-DC converter.
 RMS of AC input, those are RF, AC distortion or noise signals at the input terminal change at the output terminal to stable DC voltage. Input voltage warms thin film resistor, small temperature rises of the resistor convert to DC voltage through thin film thermocouples.
 Realizes fast response time and stable conversion sensitivity.
 LP34TW houses dual resistor-thermocouple pair and the dual balanced type has more stable characteristics in ambient temperature changes.
 Tiny smd detector for DC to a few GHz applications also available. Please contact the factory.
 For RF power measurements, RMS-DC conversion, and thermal converter applications.

Dimensions and Pin Configuration

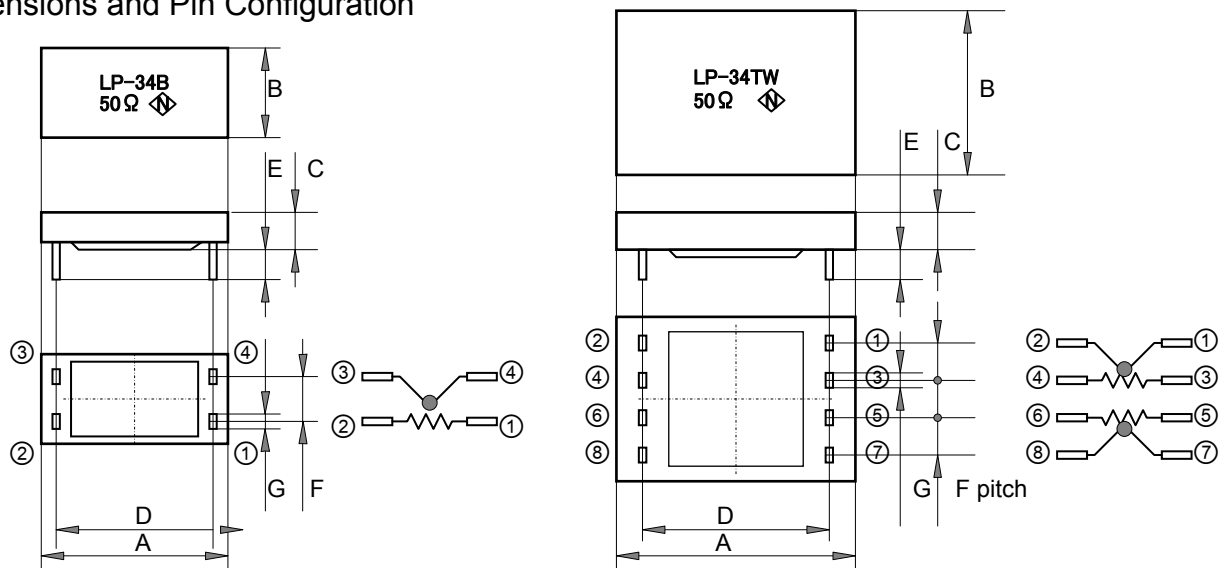

Type	A	B	C	D	E	F	G
LP34B	25.0	12.5	4.5	20.5	5.0	5.08	0.4
LP34TW	32.0	22.0	5.5	25.5	3.5	5.08	0.4

RMS-DC CONVERTER

LP-34B, LP34TW

Ordering Information

Type LP34TW	TCR ----	Input Resistance 50R0	Tolerance K	Code 000
LP34B	----	50R0	K (+/-10%)	000 (not RoHS)
LP34TW		75R0		

Specifications and Performances

Type	LP-34B, Single	LP-34TW, Dual	Conditions
INPUT			
Rated Power	10mW	10mW	
Max Applied Power	20mW	20mW	
Resistance	50Ω or 75Ω	50Ω or 75Ω	
TCR	+/-100ppm/K	+/-100ppm/K	
Tolerance	+5% , - 30%	+5%, - 30%	
Ratio	-	5%	
Frequency Range	DC-120MHz	DC-20MHz	
OUTPUT			
Sensitivity	> 2.0mV/mW	> 1.4mV/mW	
TC of Sensitivity	(-0.2% +/- 0.1%)/C	(-0.2% +/- 0.1%)/C	
Linearity Error	< 1.5% / 1mV-13mV	-	
Diff. of Linearity	-	< +/- 2.0%	
Diff. of Sensitivities	-	< +/- 8.0%	
Internal Resistance	< 3KΩ	< 12KΩ	
Response Time	< 0.3 seconds	< 0.3 seconds	63% response
Operating Temp.	-10C – 60C	-10C – 60C	
Storage Temp.	-20C – 80C	-20C – 80C	
Weight			

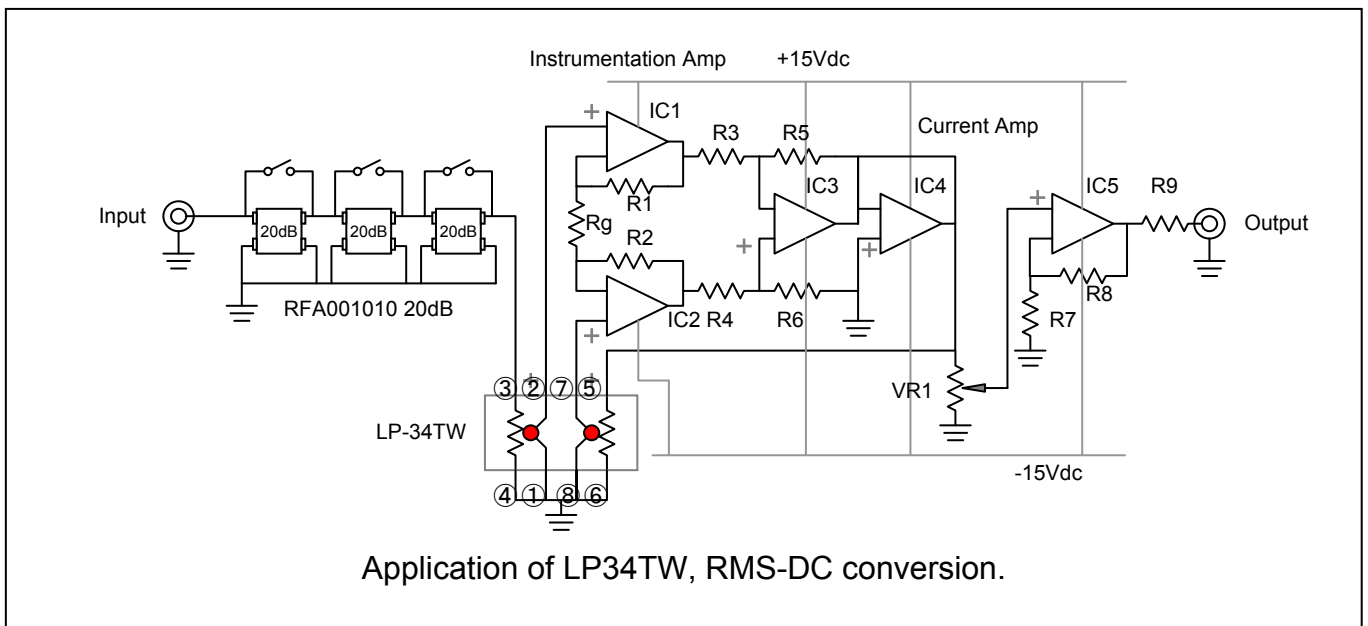

**THERMOPILE, RADIATION POWER SENSING DEVICES
LP111S, LP231S, LP31B**

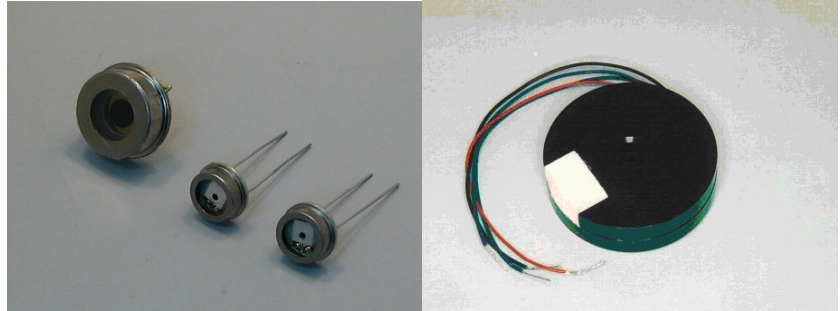

Features and Applications

Thin film thermopiles for such radiation power sensing as CO₂ laser and infra-red optical power. Fast response (LP111S), high stability (LP231S) and including incident power calibration system (LP31B) are distinctive feature.

Optical chopper that is always prepared in pyro-electricity sensor is unnecessary. Stable +/-DC output voltage is observed without influence from ambient temperature change. Wide and flat sensitivity characteristics at 0.2 to 20 micro-meter wave length are available. Low output impedance less than 10 K ohm gives easy amplifier circuit construction. None-contact temperature measurement, laser power measurement, power stabilization of laser generator and radiation optical power measurements.

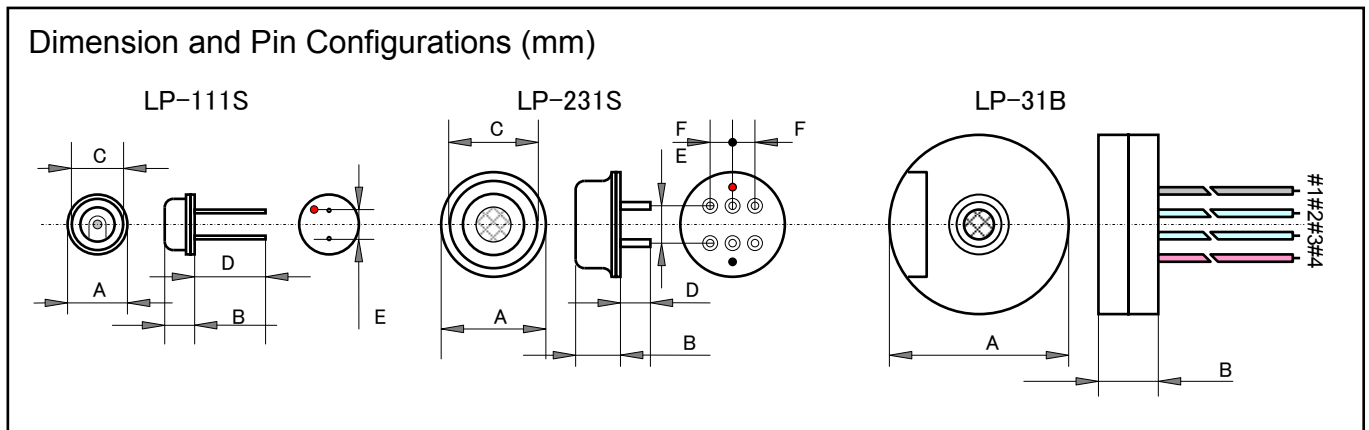

(mm)	A	B	C	D	E	F
LP-111S	9.05 dia.	3.5	8.1 dia.	17+/-2	5.0	-
LP-123	9.05 dia.	3.5	8.1 dia.	17+/-2	5.0	-
LP-231S	15.24 dia.	4.4	14.0 dia.	-	7.62	2.54
LP-31B	38.0 dia.	10.0	-	-	-	-

Ordering Information

Type	TCR	Resistance	Tolerance	Code	Note
LP-111S	---	---	---	000	Not RoHS
LP-123					
LP-231					
LP-31B					

THERMOPILE – NIKKOHM

THERMOPILE, RADIATION POWER SENSING DEVICES LP111S, LP231S, LP31B

Specifications

	p/n	LP-111S	LP-123	LP-231S	LP-31B
INPUT	Range of Detecting Wave Length (um)	0.4-20.0	0.4-20.0	0.4-20.0	0.4-20.0
	Material of Absorption Black	Metal Black	Metal Black	Metal Black	Metal Black
	Continuous Max. Input Power(mW)	10	10	10	10
	Warning Input Power(mW)	20	20	50	200
	Diameter of Detecting Aperture, (mm dia.)	1.0	1.0	4.5	5.0
OUTPUT	Sensitivity (mV/mW)	10.0	5.0	4.5	0.45
	Error from Linearity	-	-	-	-
	Internal Resistance (kohms)	2.0+/-1.0	2.0+/-1.0	4.0+/-2.0	6.5+/-3.5
	63% Response Time (ms)	45	45	250	4,000
	Number of Thermo Couple (pairs)	22	11	30	36
CALIBRATION	Resistance of Calibration Resistor (ohms)	---	---	---	250-500
MECHANICAL	Storage Temperature (deg C)	0-40	0-40	0-40	0-40
	Operation Temperature (deg C)	0-40	0-40	0-40	0-40

Schematics and Pin Connections

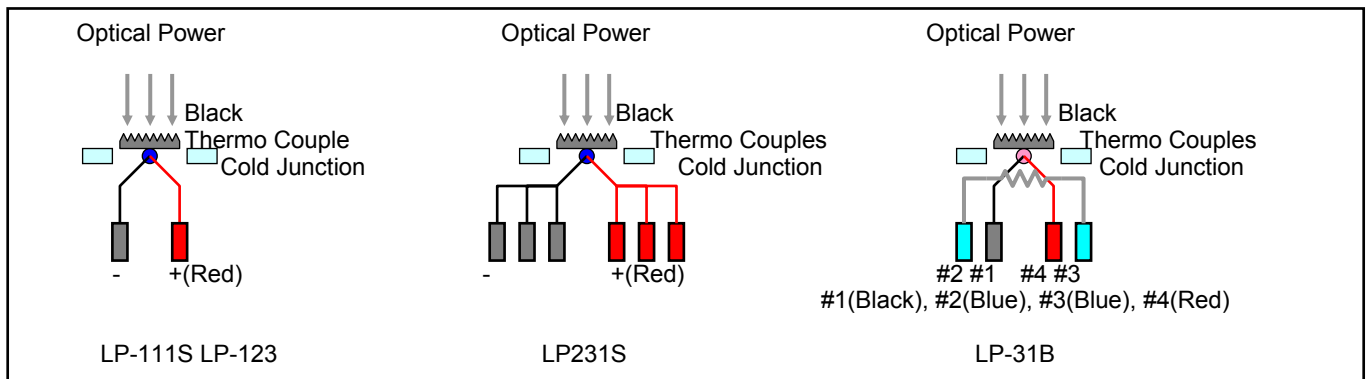

Typical Sensing Amplifier

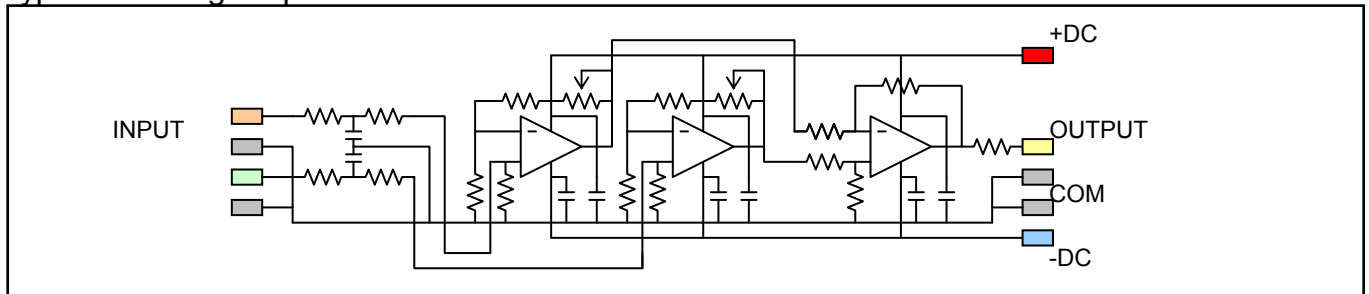

Standard Significant Resistance Value, TCR code and Tolerance code, '+' shows modified

E6+	E12+	E24+		E96+						
1.0	1.0	1.0	3.3	1.00	1.43	2.05	2.94	4.22	6.04	8.66
1.5	1.2	1.1	3.6	1.02	1.47	2.10	3.01	4.32	6.19	8.87
2.2	1.5	1.2	3.9	1.05	1.50	2.15	3.09	4.42	6.34	9.09
3.3	1.8	1.3	4.3	1.07	1.54	2.21	3.16	4.53	6.49	9.31
4.7	2.2	1.5	4.7	1.10	1.58	2.26	3.24	4.64	6.65	9.53
(5.0)	2.7	1.6	(5.0)	1.13	1.62	2.32	3.32	4.75	6.81	9.76
6.8	3.3	1.8	5.1	1.15	1.65	2.37	3.40	4.87	6.98	
	3.9	2.0	5.6	1.18	1.69	2.43	3.48	4.99	7.15	
	4.7	2.2	6.2	1.21	1.74	2.49	3.57	5.11	7.32	
	(5.0)	2.4	6.8	1.24	1.78	2.55	3.65	5.23	7.50	
	5.6	(2.5)	7.5	1.27	1.82	2.61	3.74	5.36	7.68	
	6.8	2.7	8.2	1.30	1.87	2.67	3.83	5.49	7.87	
	8.2	3.0	9.1	1.33	1.91	2.74	3.92	5.62	8.06	
				1.37	1.96	2.80	4.02	5.76	8.25	
				1.40	2.00	2.87	4.12	5.90	8.45	

Table 1. Resistance value, E6+, E12+, E24+ and E96+

TCR		Tolerance	
X	+/- 1ppm/C	T	+/-0.01%
Y	+/- 2ppm/C	Q	+0.02%
W	+/- 2.5ppm/C	A	+0.05%
Z	+/- 5ppm/C	B	+0.10%
N	+/- 10ppm/C	C	+0.25%
L	+/- 15ppm/C	D	+0.50%
E	+/- 25ppm/C	F	+1.00%
C	+/- 50ppm/C	G	+2.00%
A	+/-100ppm/C	J	+5.00%
H	+/-250ppm/C	K	+/-10.0%
		M	+/-20.0%

Table 2. TCR and Tolerance

Year	Month	Marking Date code
2011	JAN	11
2011	FEB	12
2011	MAR	13
2011	APR	14
2011	MAY	15
2011	JUN	16
2011	JUL	17
2011	AUG	18
2011	SEP	19
2011	OCT	1X
2011	NOV	1Y
2011	DEC	1Z

Table 3. Date code

Linear Resistance Change (ppm) of Ni-Cr Thin-film

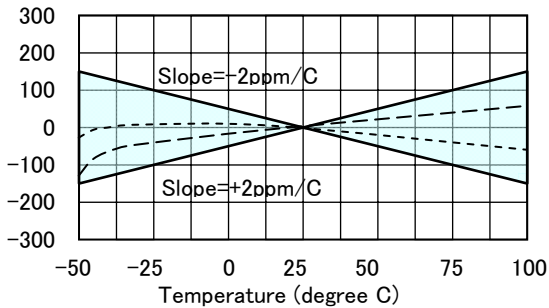

Figure 1. Resistance change of Precision.

Type	90% Failure Rate (Fit)
RP-24/RP-44	0.00003925
RNP-20S	0.00002058
RPM300	0.00620000
WSL8	0.00015000

Table 4. Failure Rate, Long Life Resistor

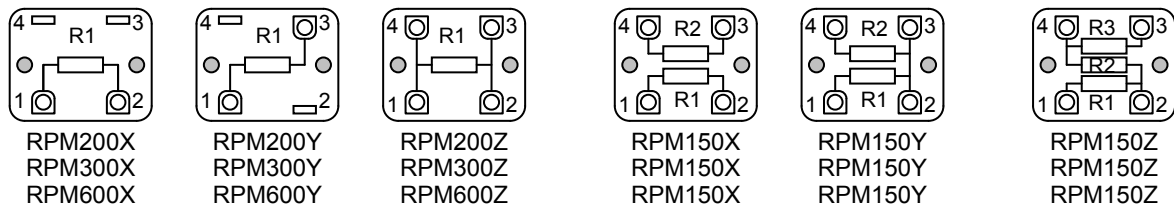

Figure 2. Schematics for SOT227 Power Resistors

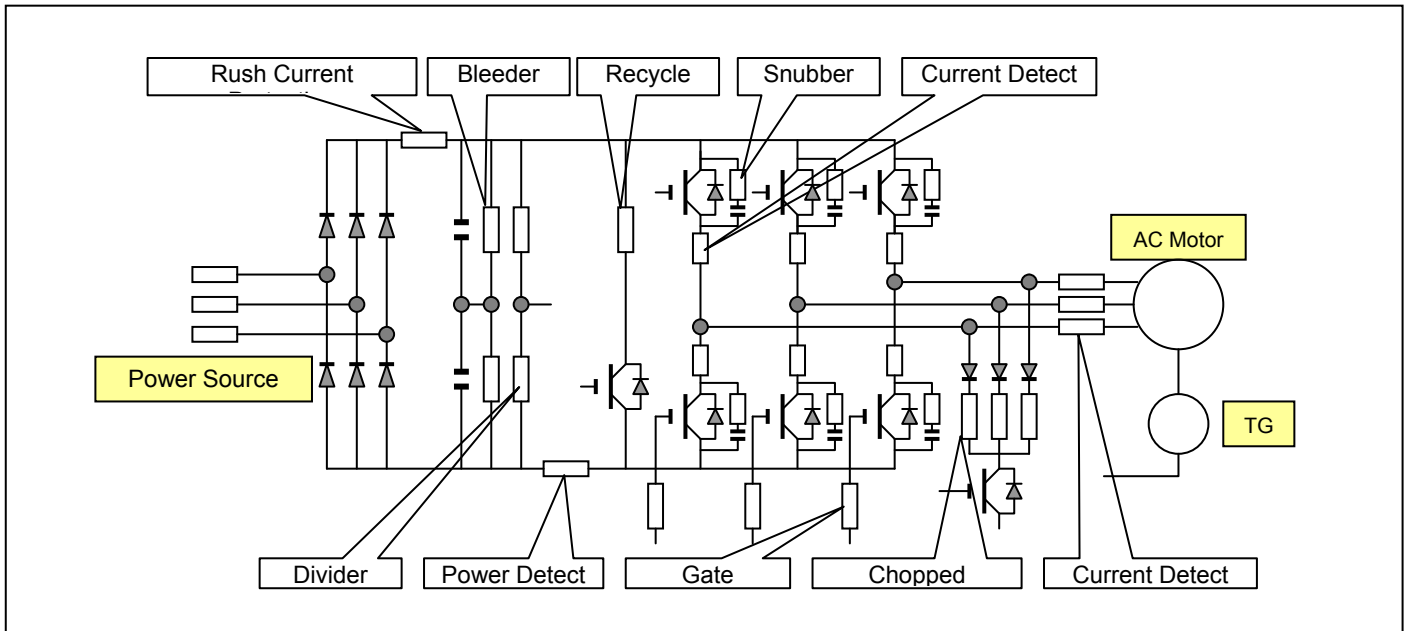

Figure 3. Power Resistor Applications in Typical Power Electronics, Motor Control

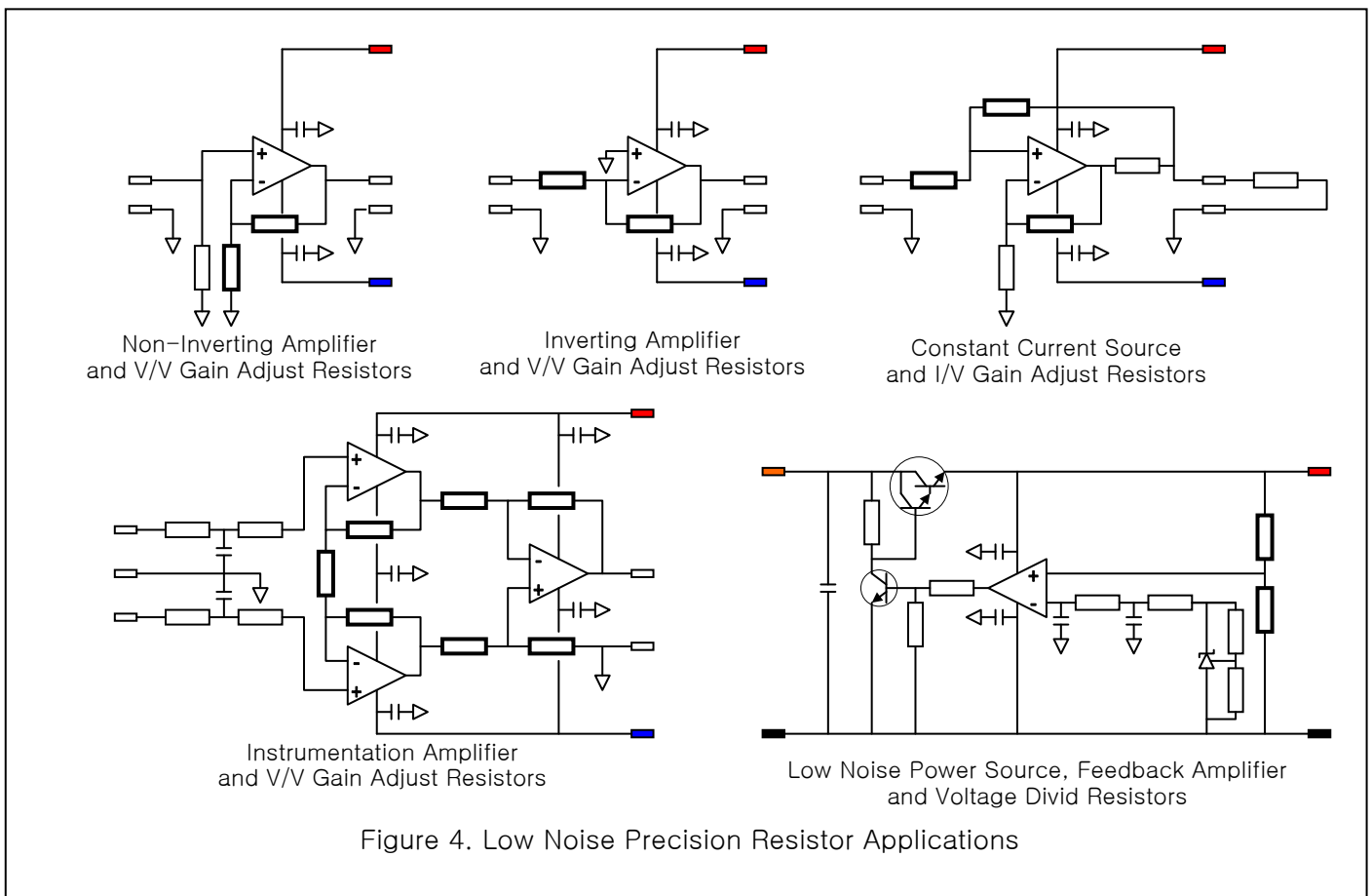
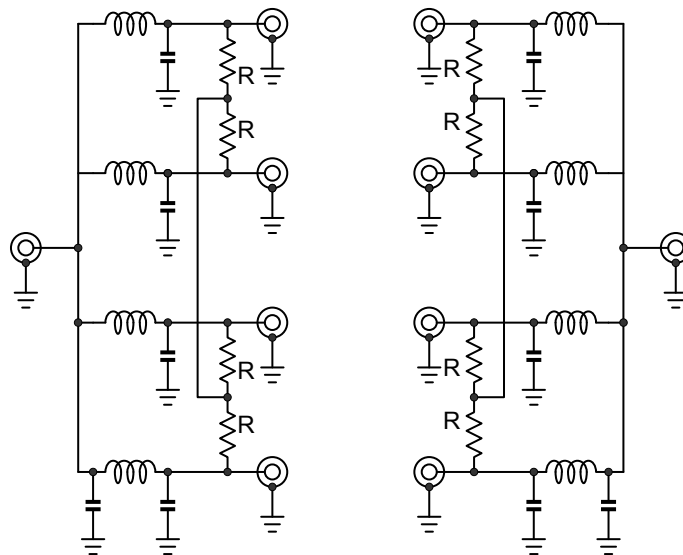
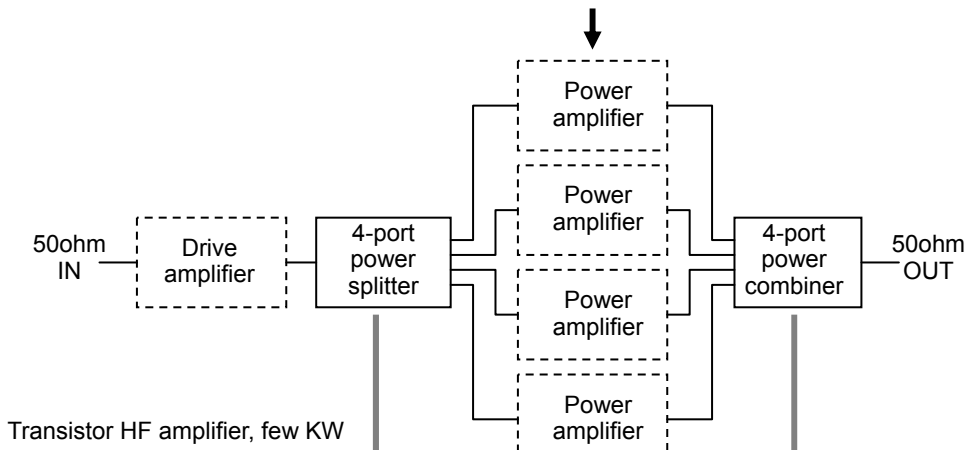
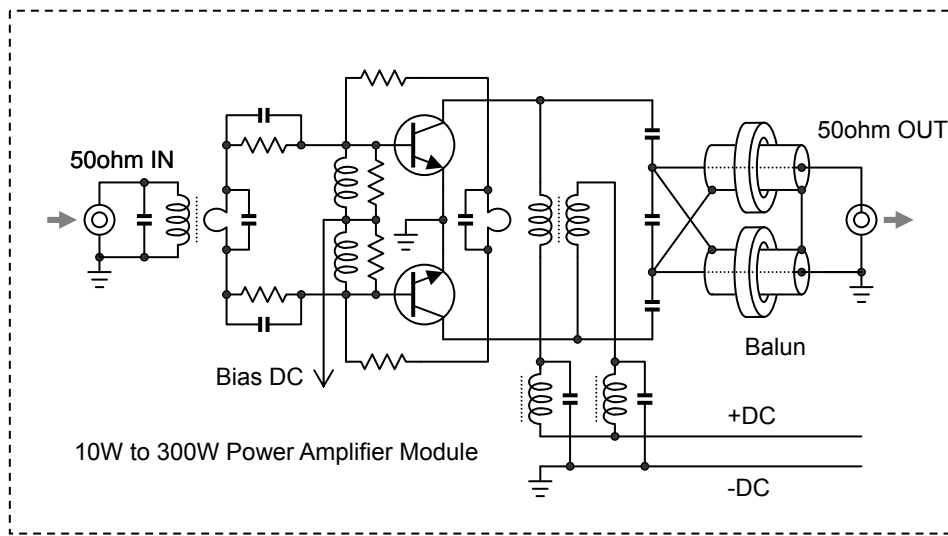

Figure 4. Low Noise Precision Resistor Applications



R: RFRF150C50ohmF/RFRF250C50ohmF

Figure 5. Lumped constant power splitter and power combiner

Return Loss, Reflection, VSWR

S11(dB)	Γ	VSWR
1	1.122018	17.3910
2	1.258925	8.7242
3	1.412538	5.8480
4	1.584893	4.4194
5	1.778279	3.5698
6	1.995262	3.0095
7	2.238721	2.6146
8	2.511886	2.3229
9	2.818383	2.0999
10	3.162278	1.9250
11	3.548134	1.7849
12	3.981072	1.6709
13	4.466836	1.5769
14	5.011872	1.4985
15	5.623413	1.4326
16	6.309573	1.3767
17	7.079458	1.3290
18	7.943282	1.2880
19	8.912509	1.2528
20	10.000000	1.2222
21	11.220185	1.1957
22	12.589254	1.1726
23	14.125375	1.1524
24	15.848932	1.1347
25	17.782794	1.1192
26	19.952623	1.1055
27	22.387211	1.0935
28	25.118864	1.0829
29	28.183829	1.0736
30	31.622777	1.0653
31	35.481339	1.0580
32	39.810717	1.0515
33	44.668359	1.0458
34	50.118723	1.0407
35	56.234133	1.0362
36	63.095734	1.0322
37	70.794578	1.0287
38	79.432823	1.0255
39	89.125094	1.0227
40	100.000000	1.0202
41	112.201845	1.0180
42	125.892541	1.0160
43	141.253754	1.0143
44	158.489319	1.0127
45	177.827941	1.0113
46	199.526231	1.0101
47	223.872114	1.0090
48	251.188643	1.0080
49	281.838293	1.0071
50	316.227766	1.0063
51	354.813389	1.0057
52	398.107171	1.0050
53	446.683592	1.0045
54	501.187234	1.0040
55	562.341325	1.0036
56	630.957344	1.0032
57	707.945784	1.0028
58	794.328235	1.0025
59	891.250938	1.0022
60	1000.000000	1.0020

Attenuation / Gain, Vout/Vin Ratio (dB)

+/- dB	Vout/Vin	Vin/Vout
0.0	1.000000	1.000000
0.1	1.011579	0.988553
0.2	1.023293	0.977237
0.3	1.035142	0.966051
0.4	1.047129	0.954993
0.5	1.059254	0.944061
0.6	1.071519	0.933254
0.7	1.083927	0.922571
0.8	1.096478	0.912011
0.9	1.109175	0.901571
1.0	1.122018	0.891251
2.0	1.258925	0.794328
3.0	1.412538	0.707946
4.0	1.584893	0.630957
5.0	1.778279	0.562341
6.0	1.995262	0.501187
7.0	2.238721	0.446684
8.0	2.511886	0.398107
9.0	2.818383	0.354813
10	3.162278	0.316228
11	3.548134	0.281838
12	3.981072	0.251189
13	4.466836	0.223872
14	5.011872	0.199526
15	5.623413	0.177828
16	6.309573	0.158489
17	7.079458	0.141254
18	7.943282	0.125893
19	8.912509	0.112202
20	10.000000	0.100000
21	11.220185	0.089125
22	12.589254	0.079433
23	14.125375	0.070795
24	15.848932	0.063096
25	17.782794	0.056234
26	19.952623	0.050119
27	22.387211	0.044668
28	25.118864	0.039811
29	28.183829	0.035481
30	31.622777	0.031623
31	35.481339	0.028184
32	39.810717	0.025119
33	44.668359	0.022387
34	50.118723	0.019953
35	56.234133	0.017783
36	63.095734	0.015849
37	70.794578	0.014125
38	79.432823	0.012589
39	89.125094	0.011220
40	100.000000	0.010000
41	112.201845	0.008913
42	125.892541	0.007943
43	141.253754	0.007079
44	158.489319	0.006310
45	177.827941	0.005623
46	199.526231	0.005012
47	223.872114	0.004467
48	251.188643	0.003981
49	281.838293	0.003548
50	316.227766	0.003162

Transformation between VSWR and S11:

$$VSWR = \frac{1+|\Gamma|}{1-|\Gamma|} \dots\dots |\Gamma| = 10^{\frac{S11}{20}}$$

$$|\Gamma| = \frac{VSWR - 1}{VSWR + 1} \dots\dots S11 = -(-20 \log |\Gamma|)$$

Resistive Attenuator and Resistance Values

Circuit T Attenuator, Impedance 50 OHMS

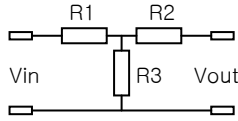

Circuit PAI Attenuator, Impedance 50 OHMS

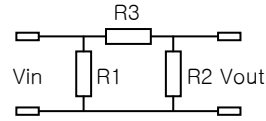

Attenuation (dB)	Vin/Vout (k)	R1 (OHMS)	R2 (OHMS)	R3 (OHMS)	Attenuation (dB)	Vin/Vout (k)	R1 (OHMS)	R2 (OHMS)	R3 (OHMS)
0	1.000				0	1.000			
1	1.122	2.875	2.875	433.337	1	1.122	869.548	869.548	5.769
2	1.259	5.731	5.731	215.240	2	1.259	436.212	436.212	11.615
3	1.413	8.550	8.550	141.926	3	1.413	292.402	292.402	17.615
4	1.585	11.314	11.314	104.829	4	1.585	220.971	220.971	23.848
5	1.778	14.006	14.006	82.241	5	1.778	178.489	178.489	30.398
6	1.995	16.614	16.614	66.931	6	1.995	150.476	150.476	37.352
7	2.239	19.124	19.124	55.802	7	2.239	130.728	130.728	44.801
8	2.512	21.525	21.525	47.309	8	2.512	116.143	116.143	52.844
9	2.818	23.811	23.811	40.592	9	2.818	104.994	104.994	61.589
10	3.162	25.975	25.975	35.136	10	3.162	96.248	96.248	71.151
11	3.548	28.013	28.013	30.616	11	3.548	89.244	89.244	81.657
12	3.981	29.924	29.924	26.810	12	3.981	83.545	83.545	93.247
13	4.467	31.708	31.708	23.568	13	4.467	78.845	78.845	106.074
14	5.012	33.366	33.366	20.780	14	5.012	74.926	74.926	120.309
15	5.623	34.902	34.902	18.363	15	5.623	71.629	71.629	136.140
16	6.310	36.319	36.319	16.257	16	6.310	68.834	68.834	153.777
17	7.079	37.623	37.623	14.413	17	7.079	66.449	66.449	173.455
18	7.943	38.818	38.818	12.792	18	7.943	64.402	64.402	195.435
19	8.913	39.912	39.912	11.363	19	8.913	62.638	62.638	220.008
20	10.000	40.909	40.909	10.101	20	10.000	61.111	61.111	247.500
21	11.220	41.817	41.817	8.984	21	11.220	59.785	59.785	278.276
22	12.589	42.641	42.641	7.994	22	12.589	58.629	58.629	312.746
23	14.125	43.389	43.389	7.115	23	14.125	57.619	57.619	351.365
24	15.849	44.065	44.065	6.335	24	15.849	56.734	56.734	394.646
25	17.783	44.676	44.676	5.641	25	17.783	55.958	55.958	443.164
26	19.953	45.227	45.227	5.024	26	19.953	55.276	55.276	497.563
27	22.387	45.724	45.724	4.476	27	22.387	54.676	54.676	558.564
28	25.119	46.171	46.171	3.987	28	25.119	54.146	54.146	626.976
29	28.184	46.573	46.573	3.553	29	28.184	53.679	53.679	703.709
30	31.623	46.935	46.935	3.165	30	31.623	53.266	53.266	789.779
31	35.481	47.259	47.259	2.821	31	35.481	52.900	52.900	886.329
32	39.811	47.550	47.550	2.513	32	39.811	52.577	52.577	994.640
33	44.668	47.810	47.810	2.240	33	44.668	52.290	52.290	1,116.149
34	50.119	48.044	48.044	1.996	34	50.119	52.036	52.036	1,252.469
35	56.234	48.253	48.253	1.779	35	56.234	51.810	51.810	1,405.409
36	63.096	48.440	48.440	1.585	36	63.096	51.610	51.610	1,576.997
37	70.795	48.607	48.607	1.413	37	70.795	51.433	51.433	1,769.511
38	79.433	48.757	48.757	1.259	38	79.433	51.275	51.275	1,985.506
39	89.125	48.890	48.890	1.122	39	89.125	51.135	51.135	2,227.847
40	100.000	49.010	49.010	1.000	40	100.000	51.010	51.010	2,499.750

www.Nikkohm.com



Nikkohm Co., Ltd. (Misawa Factory)

3-31-2640 Minamicho Misawashi Aomori 033-0036 Japan

TEL: +81-176-53-2105 FAX: +81-176-53-2106

customer service : info@nikkohm.co.jp