

TO263 SURFACE MOUNT
35W HIGH POWER RESISTORS

RNP-20E (AEC-Q200)

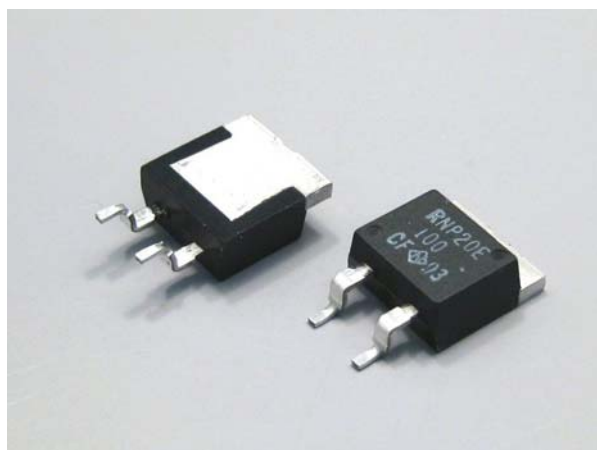

Features and Applications

35W high power resistors in TO263 (D2-PAK) style surface mount mold package with matte Tin plated flange.
 Non-inductive design suits high frequency applications and high-speed pulse circuits.
 Low, 3.3°C heat resistance from resistor hot spot to flange and long life performance are presented with thin film metallization technology.
 Wide, 10 milliohm to 51K Ohm resistance range, non-inductive impedance characteristic and heat extracting through insulated metal flange aids circuit designers.
 Applications include snubber, gate control, bleeder, filter, rush current protection, braking resistors of automotive, rail traction, wind turbine, PV, UPS and motor control inverters.

Dimensional Specifications (mm)

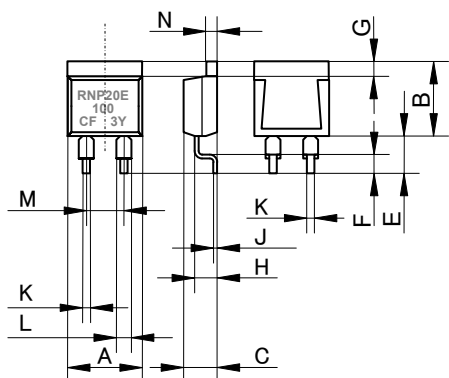

RNP-20E		
	mm	+/-mm
A	10.1	+/-0.2
B	10.3	+/-0.2
C	4.5	+/-0.2
D	-	-
E	5.0	+/-1.0
F	2.5	+/-0.5
G	2.2	+/-0.2
H	2.75	+/-0.2
J	0.5	+/-0.05
K	0.75	+/-0.05
L	1.5	+/-0.05
M	5.08	+/-0.10
N	1.5	+/-0.05

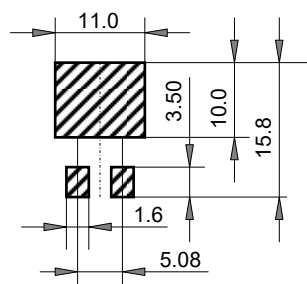

Recommended Land Pattern. (mm)
 Additional heat cooling system will be necessary

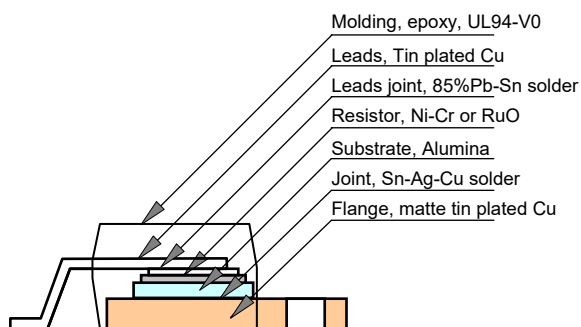
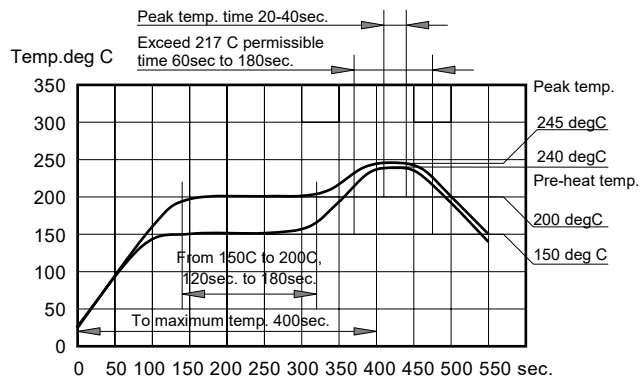

Between flange and resistor is insulated.

Ordering Information

Model	TCR	Resistance Value	Tolerance	Packaging	Remarks
RNP-20E	A	1R0 (*)	F	Z01	Tape & Reel
RNP-20E	H(>250ppm)	R02-R09 (+E6)	J(5%)	Z01(Tape)	Z: RoHS
	A(100ppm)	R10-9R1(+E24)	F(1%)	Z03(Tube)	
	C(50ppm)	10R-51K (+E24)	F(1%)	Z05(Tray)*	

* TO263 type resistor packaging Z05 (tray) has a risk of lose of flatness, co-planarity.

Resistance value (*) is available following modified E24, +E24.

1.0	1.1	1.2	1.3	1.5	1.6	1.8	2.0	2.2	2.4	2.5	2.7	3.0	3.3
3.6	3.9	4.0	4.3	4.7	5.0	5.1	5.6	6.2	6.8	7.5	8.0	8.2	9.1

TO263 SMD 35W HIGH POWER RESISTORS

RNP-20E

Specifications

	RNP-20E			Test Conditions
Rating Power	35 Watt			-55 °C to 25 °C flange temperature
Rating Power	2 Watt			Attached on simple foot print.
Heat Resistance	3.3 °C/W			Resistor hot spot to flange
Resistance Range	0.02-0.091Ω	0.1-9.1Ω	10-51KΩ	Note 2
Nominal	E6	E24+	E24	Include 2.5, 4.0, 5.0, 8.0 and 16
TCR(ppm/°C)	250(H)	100 (A)	50 (C)	Note 3.
Tolerance	5%(J)	1% (F), 5% (J)	+/-1% (F)	1% tolerance at 0.01-0.091 Ω are available.
Resistor Material	Thick Film		Thin Film	
Capacitance	1.44pF			Equivalent parallel capacitance.
Inductance	8.38nH			Equivalent series inductance
Operation Temp.	-55 °C to +175 °C			
Operating Volt.	Either 500V or $\sqrt{P \cdot R}$			P is rating power and R resistance
Withstanding Volt.	2000 VAC			Terminal and flange, 60 seconds. 1mA
Load Life	+/- 1.0 %			25 °C, 90 min.ON, 30 min. OFF, 1000h.
Humidity	+/- 1.0 %			40 °C, 90-95%RH, DC 0.1W, 1000 hours.
Temp. Cycle	+/- 0.25 %			-55 °C,30 min.,+155 °C,30 min., 5cyc
Soldering Heat	+/- 0.1 %			350+/-5 °C, 3seconds.
Lead Solder ability	Over 95% of surface			245+/-5 °C, 3seconds.
Insulation Resistance	Over 1,000 Meg Ω			Between terminals and tab.
Vibration	+/- 0.25 %			IEC60068-2-6, see note 4
Flammability	UL94-V0			
Weight	1.5 grams			

Pulse Energy Durability

Power Derating

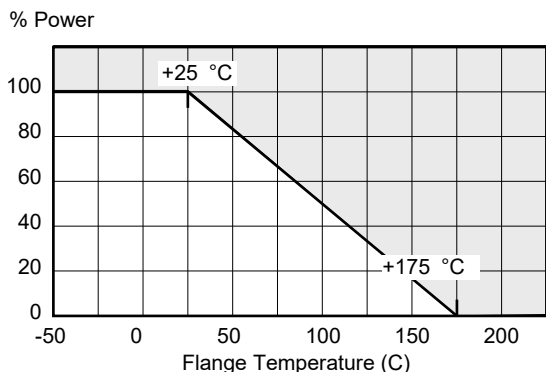

Pulse peak power (W)

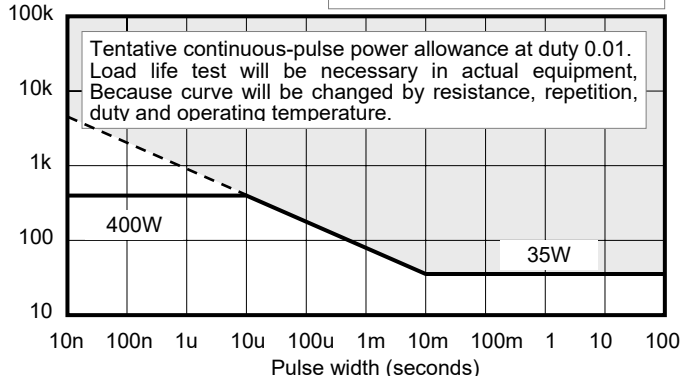

Tape Dimension

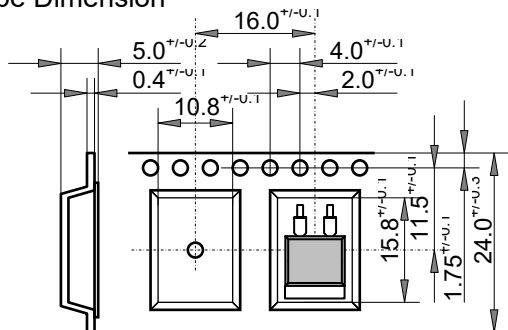

Reel Dimension

Outer diameter: 330 mm
 Inner diameter: 100 mm
 Width: 23.9 mm min. 27.4 mm max
 Package quantity: 500pcs/13 inches reel

Note:

- (1) Flange insulation is not necessary between flange and heat-sink, flange and resistor is separated by alumina substrate.
- (2) Resistance measurement shall be made at terminal foot position.
- (3) TCR of low resistance will be increased as 300ppm/0.02Ω, 200ppm/0.05Ω, 140ppm/0.1Ω and 80ppm/0.2Ω typically. Testing point is at 5.27mm from bottom of molding of terminals.
- (4) Test method is IEC60068-2-6, and specification is sine sweep wave form, 100Hz-2000Hz, 10 cycles, amplitude 0.75mm or 100m/s², 90minutes. direction x-y z, Amplitude 0.75mm will be applied under break point Frequency (about 60Hz) and 100m/ s² over break point
- (5) Standard packaging is tape reel, a tape reel contains 500pcs. In case of small quantity, tube packaging 50pcs/tube or 100pcs/tray is available.