

RF CURRENT DETECT RESISTORS

RAF-30



Features and Applications

1milliohm to 10milliohm, 30W rating power, Kelvin 4 terminal, bus-bar attachment type, precision current detector.

Inductance influence has been decreased through the small distance between current terminals.

Applications include industrial measurement, measuring instruments, precision power supply, precision equipment power supply, constant current power supply, IC test equipment, ac motor control, actuator control, inverters, IPM, rechargeable battery charge circuits, etc.

Dimensions (mm)

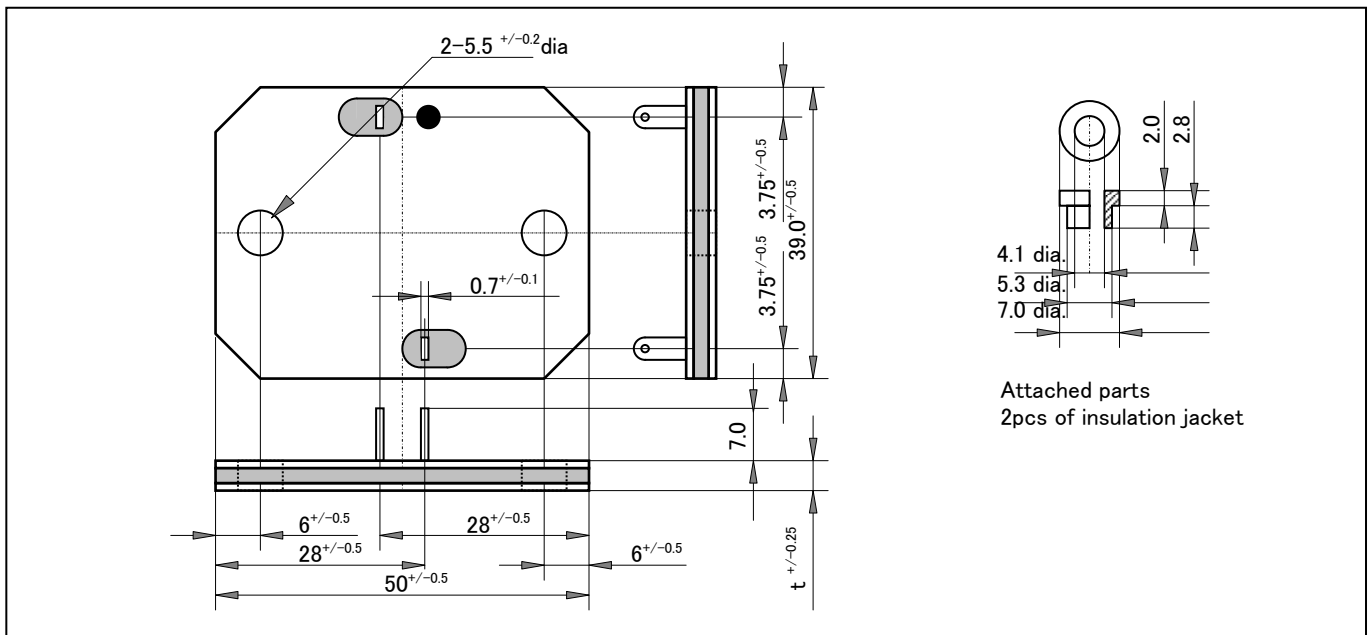

Ordering Information

Type	TCR	Resistance	Tolerance	Code	Note
RAF-30	C	0R001	F (1%)	000	
RAF-30	C (50ppm/C)	0R001	F (1.0 %)	000	Not RoHS
	E (25ppm/C)	0R002	D (0.5 %)		
		0R003			
		0R004			
		0R005			
		0R008			
		0R010			

RF CURRENT DETECT RESISTORS

RAF-30

Specifications

	Specifications	Conditions
Power Rating	30W with heat sink (Bus Bar)	
Rating Temperature	-55 to +125 degree C	
Resistance	1 milliohm to 10 milliohms	
Tolerance	+/-0.5%(D), +/-1.0%(F),	
TCR	+/-50ppm/K (C), +/-25ppm/K (E)	
Thermal EMF	Less than 1micro Volts in 0 to 100 degree C.	
Operating Temperature	-55 to +125 degree C	
Weight	38 grams	

Notes: Thickness, t=2.7mm (1m ohm), t=2.4mm (2m ohm), t=2.3mm(> 4 mohm)

Power Derating

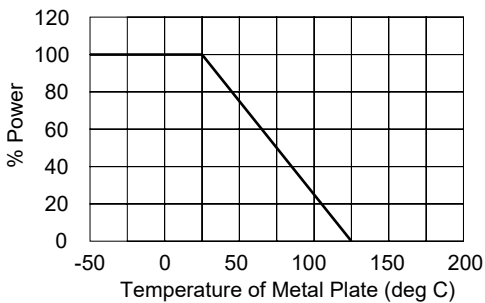

Temperature Rise

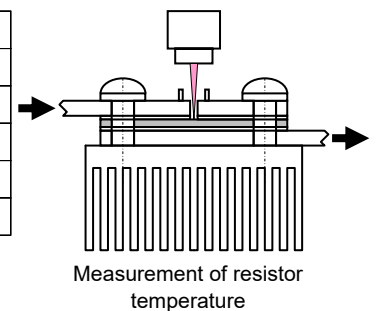
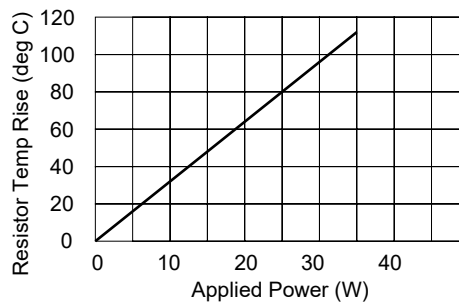

Polarization and Inside Structure

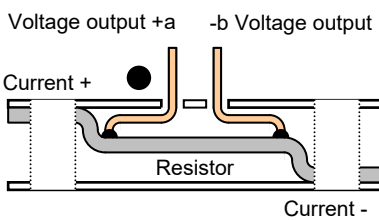
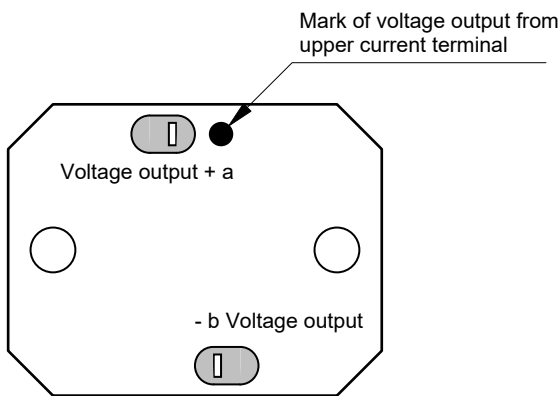

Typical installation for current bus

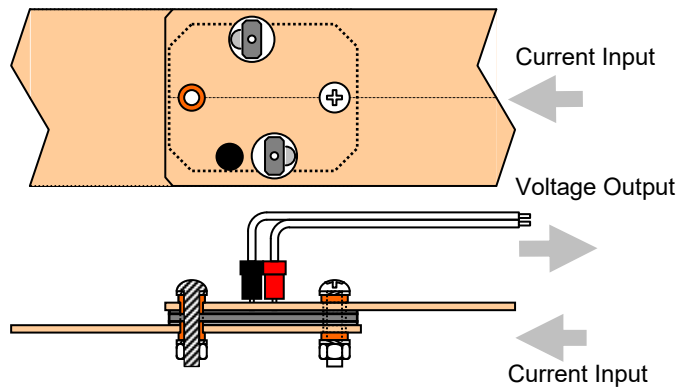

Typical schematic for current detector

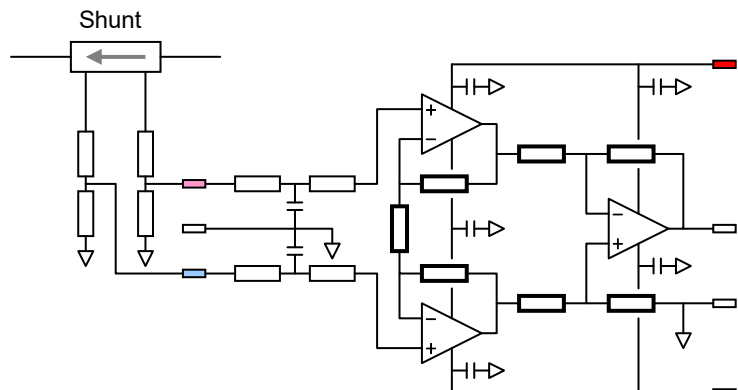

20220901