

HS10, HS15, HS25, HS50,
HS75, HS100, HS150,
HS200, HS250, HS300

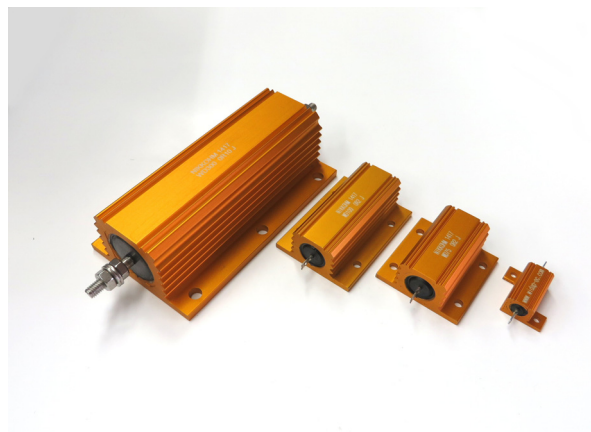

Features and Applications

- Power rating 10W to 300W, for rush current protection.
- High temperature operation, -25°C to 200 °C and all welded construction.
- Low TCR 25ppm/°C(over 1kΩ), Tolerance 5% in standard and available up to 1%.
- Non-inductive winding is available, called NHS instead of HS.
- IEC-115 と MIL-R-18546 requirements.
- Applications include inverters for power electronics

Dimensions (mm)

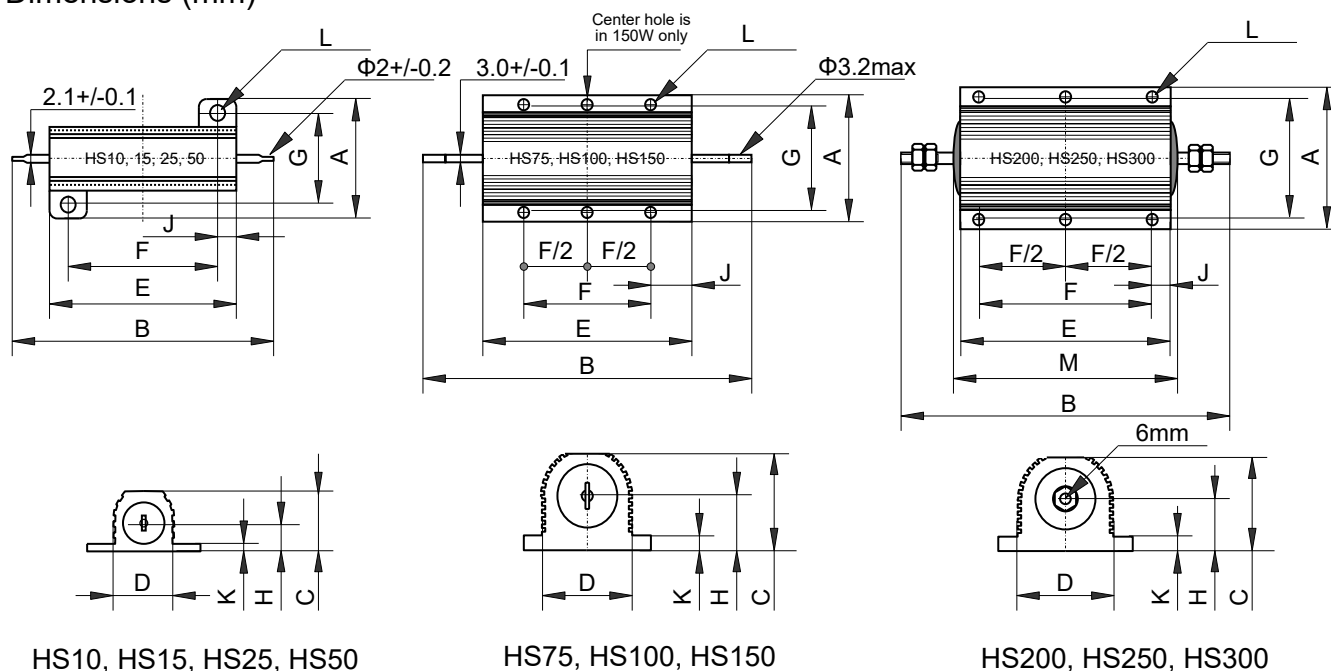

| (mm) | A | B | C | D | E | F | G | H | J | K | L | M |
|-------|------|-------|------|------|-------|-------|------|------|------|-----|-------|-------|
| | Max | Max | Max | Max | Max | ±0.3 | ±0.3 | Max | Max | Max | ±0.25 | Max |
| HS10 | 16.5 | 30.0 | 8.8 | 8.5 | 15.9 | 11.3 | 12.4 | 4.5 | 2.4 | 1.8 | 2.4 | --- |
| HS15 | 21.0 | 36.5 | 11.0 | 11.2 | 19.9 | 14.3 | 15.9 | 5.5 | 2.8 | 1.8 | 2.4 | --- |
| HS25 | 28.0 | 51.0 | 14.8 | 14.2 | 27.3 | 18.3 | 19.8 | 7.7 | 5.2 | 2.6 | 3.2 | --- |
| HS50 | 28.0 | 72.5 | 14.8 | 14.2 | 49.1 | 39.7 | 21.4 | 8.4 | 5.2 | 2.6 | 3.2 | --- |
| HS75 | 47.5 | 72.0 | 24.1 | 27.3 | 48.7 | 29.0 | 37.0 | 11.8 | 10.4 | 3.7 | 4.4 | --- |
| HS100 | 47.5 | 88.0 | 24.1 | 27.3 | 65.2 | 35.0 | 37.0 | 11.8 | 15.4 | 3.7 | 4.4 | --- |
| HS150 | 47.5 | 121.0 | 24.1 | 27.3 | 97.7 | 58.0 | 37.0 | 11.8 | 20.4 | 3.7 | 4.4 | --- |
| HS200 | 72.5 | 145.7 | 41.8 | 45.5 | 89.7 | 70.0 | 57.2 | 20.5 | 10.4 | 5.5 | 5.1 | 103.4 |
| HS250 | 72.5 | 167.0 | 41.8 | 45.5 | 109.7 | 89.0 | 57.2 | 20.5 | 10.4 | 5.5 | 5.1 | 122.4 |
| HS300 | 72.5 | 184.4 | 41.8 | 45.5 | 127.7 | 104.0 | 59.0 | 20.5 | 12.4 | 5.5 | 6.6 | 141.4 |

HS10, HS15, HS25, HS50, HS75, HS100, HS150, HS200, HS250, HS300

Power Rating and Resistance

| Type () MIL-R-18546 | Power Rating (W @ 25°C) | | Resistance Range (Ω) * | Limiting Element Volt | Voltage Proof (AC peak Volt) | Weight approx. grams | Std. Heat sink cm ² – thickness mm |
|----------------------------|------------------------------|---------------------------------|---------------------------|--------------------------|---------------------------------|-------------------------|--|
| | With heat sink (W @ 25°C) | Without heat sink (W @ 25°C) | | | | | |
| HS10 (RE60) | 10 | 5 | R005 - 10k | 160 | 1400 | 4 | 415 - 1 |
| HS15 (RE65) | 15 | 7 | R005 - 10k | 260 | 1400 | 7 | 415 - 1 |
| HS25 (RE70) | 25 | 9 | R005 - 36k | 550 | 3500 | 14 | 535 - 1 |
| HS50 (RE75) | 50 | 14 | R01 - 86k | 1250 | 3500 | 32 | 535 - 1 |
| HS75 | 75 | 24 | R01 - 50K | 1400 | 6363 | 85 | 996 - 3 |
| HS100 | 100 | 30 | R01 - 70K | 1800 | 6363 | 115 | 996 - 3 |
| HS150 | 150 | 45 | R01 - 100K | 2500 | 6363 | 175 | 996 - 3 |
| HS200 | 200 | 50 | R01 - 50K | 1900 | 7070 | 475 | 3750 - 3 |
| HS250 | 250 | 55 | R01 - 50K | 2200 | 7070 | 600 | 4766 - 3 |
| HS300 | 300 | 60 | R01 - 60K | 2500 | 7070 | 700 | 5780 - 3 |

* non inductive winding reduce maximum resistance range to 1/4,

Ordering Information

| | | | |
|----------------|--------------------------|--------------------|--------------------------|
| Model HS75 | Resistance 50Ω | Tolerance 5%, J | Package Code Z00 |
| HS5 / NHS5 | Any value in above table | 1.00%, F | Z shows RoHS 2 compliant |
| HS10 / NHS10 | | 5.00% J, STD | |
| HS25 / NHS25 | 10% K | | |
| HS50 / NHS50 | | | |
| HS100 / NHS100 | | | |
| HS150 / NHS150 | | | |
| HS200 / NHS200 | | | |
| HS250 / NHS250 | | | |
| HS300 / NHS300 | | | |

For non-inductive windings, please attach 'N' before 'HS' as 'NHS'
Non-inductive windings are available on minimum resistance 0.1 Ω or more.

Derating

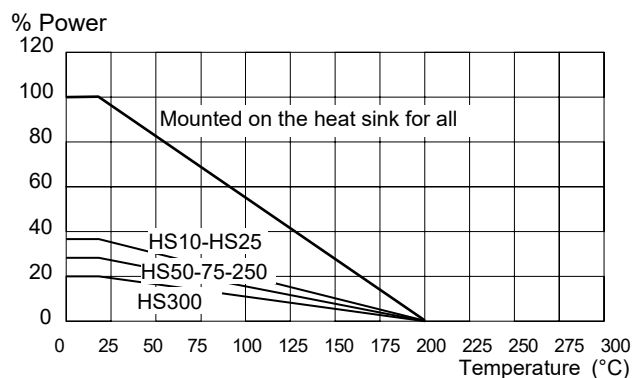

Surface Temperature Rise

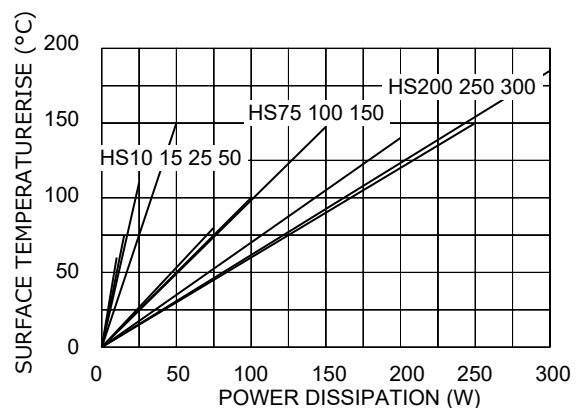

Specifications and Performances

| | | |
|------------------------------|---|---|
| Tolerance | (for values greater than 0.05 Ω) (for values less than 0.05 Ω) | >=R05 (+/-5%) < R047 (+/-10%) |
| TCR | Dry / Normal | 100 ppm/°C (< 1K0), 25 ppm/°C (>1K0) |
| Insulation Resistance | Dry / Normal | minimum 10 GΩ. |
| Load Life | 90min ON, 30min OFF 1000 hours | ΔR < 1% + 0R05 |
| Short time Overload | X 10 rated power for 5 sec , once | ΔR < 1% + 0R05 |
| Terminal Strength | 20 N Pull | ΔR < 0.25% +0R05 |
| Resistance of soldering Heat | 260 °C 10 seconds | ΔR < 0.25% +0R05 |
| Thermal Shock | -55 °C - +200 °C, 5 cycles | ΔR < 0.25% +0R05 |
| Vibration | 10Hz to 500Hz, 10g, 6 hours | ΔR < 0.25% +0R05 |

20231001